

MOGAN

DIN rail Modular Devices



Committed to becoming a world-class manufacturer of intelligent electric



COMPANY PROFILE

MAXGE Electric Technology Co., Ltd was founded in 2006 with a registered capital of 50 million RMB. Its headquarter is located in Deqing County, Huzhou City, Zhejiang Province. It is a large-scale comprehensive high-tech enterprise integrating design, research and development, manufacturing, marketing and service.

Since its establishment, MAXGE has been professionally oriented and committed to the design and manufacturing of a series of products such as low voltage circuit breakers & controlgear for domestic, industrial protection and new energy power distribution, in order to meet user needs and provide high-quality solutions.

At present, MAXGE has won many honors such as National High-tech Enterprise, National Specialized and Sophisticated "Little Giant", Zhejiang Enterprise Technology Center, Zhejiang High-level Enterprise R&D Center, Zhejiang Export Brand and Zhejiang Digital Workshop.

In the process of production and operation, we have obtained ISO9001, ISO14001 and ISO45001 and obtained SGS certifications, and the testing center has won the national CNAS laboratory certification. The products have obtained CE, CB, VDE, KEMA, TUV, INTERTEK, BV, ASTA, EAC, INMETRO certifications with reliable quality, and are exported to more than 60 countries and regions such as the European Union, the South America, Middle East, Africa, and Southeast Asia. We have multiple branches in the United Kingdom, Spain, Netherlands and Hong Kong, and we are dedicated to providing high-quality products and services to global customers.



2006

The Company Was
Established In 2006

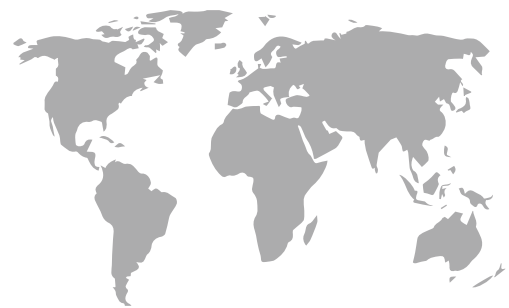

60⁺

We Provide Products To Over
60 Countries Around The World

Currently MAXGE has a R&D team of more than 100 personnel and nearly 1,000 employees, equipped with state of the art automatic production lines, CNAS affiliated laboratories and testing centers. MAXGE has obtained more than 100 invention and utility model patents, 10 software copyright, and participated in the formulation of national, industry and group standards.

There are over 133,000 square meters of Modern Intelligent Manufacturing Bases in Zhejiang Hangzhou, Huzhou and Anhui Wuhu.

The Huzhou factory covers an area of over 33,000 square meters, with a total investment of 500 million RMB. At present, there are 42 production lines in the automation workshops, among which the automatic assembly production line, semi-automatic assembly production line and automatic inspection line cover more than 90%.

DEVELOPMENT HISTORY

(2006 to 2010)
Development

1.0

Brand Establishment

Wenzhou Maxge Electric Technology Co, Ltd. was established, and focused on circuit breakers manufacturing.

1.0

(2011 to 2015)
Development

2.0

Thrive Period

Moved to Deqing County, entered into a new stage and focused on the design, development and production of low-voltage Circuit Breakers.

2.0

(2016 to 2020)
Development

3.0

4T+5I

- Standardization
- Automation
- Digitalization
- Intelligitization
- Products Innovation
- Technology Innovation
- Management Innovation
- Marketing Innovation
- Brand Innovation

3.0

(2021 to 2025)

Development

4.0

Comprehensive Transformation

The production capacity of Wuhu greenfield factory can reach 3 times bigger after construction. Not only focus on foreign markets, but also prepared for the domestic market.

(2026 to 2030)

Development

5.0

Green and Smart

MAXGE provides users with more diversified, intelligent and creative solutions, and promote the whole society towards the goal of green, intelligent and sustainable development.

4.0

5.0



CORPORATE CULTURE



Brand Interpretation

- Chinese Name: Mei Gao
- Mei: Perfection in Excellence
- Gao: Virtue in Action
- English Name: MAXGE
- MAX: Maximum
- GE: Global Electric

Core values

Customer Focused
Altruism & Win-win
Truth-seeking & Innovation

Mission

Making Electricity Safe Green Smart

CULTURE

Vision

SHORT-TERM VISION :

Making the best quality & high cost performance circuit breaker in China

LONG-TERM VISION :

Committed to becoming a world-class manufacturer of intelligent electric



Lotus

The Heart of Altruism

Remain true to the original aspiration
Keep the mission firmly in mind

Link the hearts tightly
Be upright and integrity



Bodhi Tree

The Tree of Wisdom

“Stay Hungry
Stay Foolish”

Be wise and enlightened
Self-growth and self-motivated



Wukong

The Spirit of Struggle

Keep going, never give up
Strive continuously to strengthen oneself

Be loyal and trustworthy
Have ample virtue and accommodate all things

SCALE CONFIGURATION



01 Mold & Tooling Workshop

Equipped with made in Switzerland GF AgieCharmilles, Japan Sodick wire cutting machine & EDM machine and Vertical milling CNC processing area. At present, it has achieved independent design, manufacturing and production of press tools & molds, with a comprehensive manufacturing capacity of more than 30 sets per month. Now the complete mold manufacturing process has been established, and an independent mold quality inspection group is equipped to realize the full inspection of the mold processing to ensure the precision and accuracy of mold.



02 Stamping Workshop

Equipped with high & medium speed stamping presses, and auxiliary equipment. The average punching speed can reach 100 to 300 strokes per minute, the highest punching speed can reach 500 strokes per minute, and the monthly production capacity of the workshop is to cater stamped parts for 5 million MCB, 500K RCCB, 500K RCBO & 200K MCCB.



03 Spot Welding Workshop

Equipped with automatic coil winding machines, automatic braid compacting & cutting machines, automatic thermal and magnetic welding group assembly machines, automatic armature assembly machines, automatic pad printing on handle and latch holder machines. The automation level is over 90%, and it is mainly responsible for the production of welding groups required by the finished product workshop. Through the integrated technology of winding and welding, automatic welding production has been realized. Thermal assembly heat treatment process is adopted to improve first pass yield during thermal verification process.

04 Injection Molding Workshop

Equipped with 38 injection molding machines from 60 to 350 ton capacity, overhead cranes and auxiliary equipment such as automatic warpage prevention machines, mould temperature controllers, granulators. The automation level is over 90%, realizing an automatic and efficient production process. Adopted centralised material feeding system to improve production efficiency and realize effective utilization of resources. Smart humidifying room, use advanced humidification process to strengthen the mechanical properties of the product. MAXGE adapts online CCD image detection unit though which critical parts of mechanism undergoes 100% inspection to ensure delatch free breakers. Through CCD image detection equipment, efficient, accurate and reliable image detection and analysis can be realized to ensure product quality.





05 ACB Automatic Testing Line

The product will go through the steps of manual assembly, contact parameters tests such as trip force, trip distance, ACB & cradle assembly by robot ,mechanical operation test unit to verify internal accessories and motor, current characteristic test unit , high voltage and loop resistance test unit, & appearance inspection by CCD device. Automation level has reached 80% and the monthly detection capacity has reached more than 1000 ACB.



06 MCCB Automatic Workshop

It mainly produces Moulded Case Circuit Breaker such as thermal magnetic type, electronic type, and ELCB type, as well as Intelligent Air Circuit Breaker. There are currently 8 automatic production lines & one manual line, and the monthly production capacity reaches 200,000 units. It has realized the automatic assembly & inspection of the whole process, including contact parameters such as automatic open distance, overtravel, on-off, synchronicity, trip force, trip distance, loop resistance, lift force & routine tests such as magnetic, thermal, reliability & HV test. Test line also equipped with laser printing & final appearance inspection by CCD device. The automation level has reached to 80%.

07 MCB Automatic Workshop

It mainly produces Miniature Circuit Breakers. There are 11 automatic production lines and 4 U-shaped lean production lines. At present, the average monthly production capacity can reach about 5 million poles. Equipped with automatic assembly, laser printing, riveting, Deltach test, terminal screw test, thermal calibration, cooling, thermal verification, automatic multi-pole assembly, magnetic test, on-off test and high voltage test, plasma arc cleaning, laser marking, pad printing, din clip fixing, automatic packaging and other equipment, the automation level is over 90%. Through magnetic test, on-off test and high voltage test, to verify the response speed of the product and ensure that the power supply can be connected or disconnected stably. Adopt double-track automatic production line to improve production efficiency, add automatic tripping force measurement unit, conduct full inspection of products, and comprehensively monitor product quality.



08 RCCB Automatic Workshop

It mainly produces magnetic relay, electronic and electro-magnetic Residual Current Circuit Breakers, plastic and metal type single-phase and three-phase Distribution Boxes, Photovoltaic Combiner Boxes and controlgear products. There are 4 automatic production lines and 4 U-shaped lean production lines. At present, the average monthly production capacity can reach about 400,000 poles. The key component of RCCB named magnetic relay is produced in a clean room of class one rating & temperature, humidity conditions are maintained within standard range. Equipped with magnetic relay workshop grinding machine, finished product workshop automatic demagnetization machine, automatic calibration bench, automatic on-off and HV test machine, magnetic relay automatic winding machine and other equipment, the detection automation level has reached 80%.



09 RCBO Automatic Workshop

It mainly produces Residual Current Circuit Breaker with Over Current Protection with different variants such as 2P Electronic RCBO, DPN RCBO, 1P Electronic RCBO, multipole RCBO, electromagnetic type RCBO & Arc Fault Detection Device. There are 5 automatic production lines, 2 semi-automatic production lines and 3 U-shaped lean assembly lines. At present, the average monthly production capacity can reach about 500,000 poles. Equipped with automatic riveting, Deltach test, terminal screw test, magnetic test, on-off test, high voltage test, leakage current detection, thermal calibration, cooling, thermal verification, plasma arc cleaning, laser marking, pad printing and automatic packaging and other equipment, the automation level is over 85%.





MGR Series Residual Current Circuit Breaker-----01/03



EPRI Series Residual Current Circuit Breaker-----04/06



EPRI-B B-Type Residual Current Circuit Breaker -----07/10



EPBRi Series Residual Current Operated-----11/13
Circuit Breaker with overload protection



EPBR-w Series Residual Current Operated-----14/17
Circuit Breaker with overload protection



MGR-63H/M Series Residual Current Operated -----18/21
Circuit Breaker with overload protection



MGRN-32M/H Series DPN Residual Current22/25
Operated Circuit Breaker With Overload Protection



AFDD Arc Fault Detection Device -----26/32



SGRM-63LE Series Residual Current Operated-----33/44
Circuit Breaker with overload protection



1-4P

MGR 63Me/Ne/Se Series Miniature Circuit Breaker-----45/50



1-4P

MGB-63M/H Series Miniature Circuit Breaker -----51/56



1-4P

MGB-63M-DC Series Miniature Circuit Breaker -----57/60



EP-DPN Series Miniature Circuit Breaker -----61/63



1-4P

EPB-125H Series High Rated Miniature Circuit Breaker -----64/66



1-4P

MGI-R Series Isolating Switch -----67/69



EPBA Series MCB Accessory -----70/74



1-4P

EPC1 Series Modular Contactor -----75/77



EPSO Series Door Bell ----- 78/79



EP SL Series Indicating Light ----- 80/83



1-4P

SGS1 Series Surge Protective Device ----- 84/88



2-3P

SGS1-DC Series Surge Protective Device ----- 89/90



1-4P

EPF-32 Series Fuse Holder ----- 91/92



1-3P+N







EPF-63 Series Fuse Holder ----- 93/94



1-3P+N

EPF-125 Series Fuse Holder ----- 95/96

Products Overview of Residual Current Protective Devices

Product name	RCCB						RCBO			
Product range	MGR		EPri		EPri-B		EPBRi	EPBR-W	MGR-63H	MGRN-32M/H
Product picture										
Standard	IEC/EN 61008-1		IEC/EN 61008-1		IEC/EN 62423		IEC/EN 61009-1	IEC/EN 61009-1	IEC/EN 61009-1	IEC/EN 61009-1
Number of poles	2 (1P+N)	4 (3P+N)	2 (1P+N)	4 (3P+N)	2 (1P+N)	4 (3P+N)	2 (1P+N)	1P+N	1P+N	1P+N
Electrical characteristics										
Rated current(A) In	16~80		25~125		16~63		6~40	6~40	6~63	6~32
Rated voltage(V)	240VAC	415VAC	240VAC	415VAC	240VAC	415VAC	240VAC	240VAC	240VAC	240VAC
Rated residual current(mA)	10,30,100,300		10,30,100,300		30,100,300		10,30,100,300	10,30,100,300	10,30,100,300	10,30,100,300
Breaking capacity(kA)	6,10		6,10		7.5		6,10	6,10	6,10	4.5 , 6
Overload protection function	Without		Without		Without		With	With	With	With
Tripping curve	—		—		—		B,C	B,C	B,C	B,C
Residual current operating characteristic	AC,A		AC,A		B		AC,A	AC,A	AC,A	AC,A
Residual current protection mode	Electro-magnetic		Electro-magnetic		Electro-magnetic		Electronic/ Electro-magnetic	Electronic	Electronic/ Electro-magnetic	Electronic
Catalogue page No	01-03		04-06		07-10		11-13	14-17	18-21	22-25

MGR Series Residual Current Circuit Breaker

Technical data





Standard	EN / IEC61008-1
Rated conditional short-circuit current, I_{nc}	6kA, 10kA
Protection	Ground fault
Rated current, I_n	16,20,25,32,40,50,63,80A
Number of poles	2(1+N),4(3+N)pole
Rated sensitivity currents, I_{Δn}	10,30,100,300mA
Rated residual non-operating current	0.5 X I _{Δn}
Rated impulse withstand voltage U_{imp}	4kV
Rated voltage	2pole 240VAC 4pole 415 VAC
Ambient temperature (°C)	-25~+40,Max. 95%humidity
Residual current off-time at I_{Δn}	≤0.1s
Rated residual current making & breaking capacity, I_{Δm}	500A for I _n =16,25,32,40,50A 630A for I _n =63A 800A for I _n =80A
Type of trip	Electro-magnetic release
Type of terminal	Lug type and Pin type
Terminal capacity	Cables up to 25mm ²
Protection degree	IP20
Installation	35mm DIN rail



MGR-2-2P



MGR-2-4P

MGR RCD	Rated current(A)	$I_{\Delta n}$	Type AC 	Type A 	Packing unit
 MGR-2-2P	16	10mA	MGR/2/16/10	MGR/2/16/10-A	1
	20		MGR/2/20/10	MGR/2/20/10-A	1
	25		MGR/2/25/10	MGR/2/25/10-A	1
	16	30mA	MGR/2/16/30	MGR/2/16/30-A	1
	20		MGR/2/20/30	MGR/2/20/30-A	1
	25		MGR/2/25/30	MGR/2/25/30-A	1
	32		MGR/2/32/30	MGR/2/32/30-A	1
	40		MGR/2/40/30	MGR/2/40/30-A	1
	50		MGR/2/50/30	MGR/2/50/30-A	1
	63		MGR/2/63/30	MGR/2/63/30-A	1
	80		MGR/2/80/30	MGR/2/80/30-A	1
	16	100mA	MGR/2/16/100	MGR/2/16/100-A	1
	20		MGR/2/20/100	MGR/2/20/100-A	1
	25		MGR/2/25/100	MGR/2/25/100-A	1
	32		MGR/2/32/100	MGR/2/32/100-A	1
	40		MGR/2/40/100	MGR/2/40/100-A	1
	50		MGR/2/50/100	MGR/2/50/100-A	1
	63		MGR/2/63/100	MGR/2/63/100-A	1
	80		MGR/2/80/100	MGR/2/80/100-A	1
	16	300mA	MGR/2/16/300	MGR/2/16/300-A	1
	20		MGR/2/20/300	MGR/2/20/300-A	1
	25		MGR/2/25/300	MGR/2/25/300-A	1
	32		MGR/2/32/300	MGR/2/32/300-A	1
	40		MGR/2/40/300	MGR/2/40/300-A	1
50	MGR/2/50/300		MGR/2/50/300-A	1	
63	MGR/2/63/300		MGR/2/63/300-A	1	
80	MGR/2/80/300		MGR/2/80/300-A	1	
 MGR-2-4P	16	10mA	MGR/4/16/10	MGR/4/16/10-A	1
	20		MGR/4/20/10	MGR/4/20/10-A	1
	25		MGR/4/25/10	MGR/4/25/10-A	1
	16	30mA	MGR/4/16/30	MGR/4/16/30-A	1
	20		MGR/4/20/30	MGR/4/20/30-A	1
	25		MGR/4/25/30	MGR/4/25/30-A	1
	32		MGR/4/32/30	MGR/4/32/30-A	1
	40		MGR/4/40/30	MGR/4/40/30-A	1
	50		MGR/4/50/30	MGR/4/50/30-A	1
	63		MGR/4/63/30	MGR/4/63/30-A	1
	80		MGR/4/80/30	MGR/4/80/30-A	1
	16	100mA	MGR/4/16/100	MGR/4/16/100-A	1
	20		MGR/4/20/100	MGR/4/20/100-A	1
	25		MGR/4/25/100	MGR/4/25/100-A	1
	32		MGR/4/32/100	MGR/4/32/100-A	1
	40		MGR/4/40/100	MGR/4/40/100-A	1
	50		MGR/4/50/100	MGR/4/50/100-A	1
	63		MGR/4/63/100	MGR/4/63/100-A	1
	80		MGR/4/80/100	MGR/4/80/100-A	1
	16	300mA	MGR/4/16/300	MGR/4/16/300-A	1
	20		MGR/4/20/300	MGR/4/20/300-A	1
	25		MGR/4/25/300	MGR/4/25/300-A	1
	32		MGR/4/32/300	MGR/4/32/300-A	1
	40		MGR/4/40/300	MGR/4/40/300-A	1
50	MGR/4/50/300		MGR/4/50/300-A	1	
63	MGR/4/63/300		MGR/4/63/300-A	1	
80	MGR/4/80/300		MGR/4/80/300-A	1	

1. Life

In	Operating cycles		Operating frequency (operations/h)
	On-load operating cycles	Off-load operating cycles	
16,20,25,32	2000	2000	240
40,50,63,80	2000	1000	120

2. Breaking time of residual current

Max.breaking time					
In(A)	I Δ n(A)	I Δ n	2I Δ n	5I Δ n	5A,10A,20A,50A,100A,200A,500A
16,20,25,32,40,50,63,80	0.01,0.03,0.1,0.3	0.1s	0.08s	0.04s	0.04s

3. Wiring

The suitable conductors should be used for connection, see table below for relative parameters.

Rated current In (A)	Cross section area s (mm ²)	Tightening torque (N.m)
16	2.5	2.5
20	2.5	2.5
25	4	2.5
32	6	2.5
40	10	2.5
50	16	2.5
63	16	2.5
80	25	2.5

4. Features

When designing residual current devices, manufacturing technology and type of routine tests, the IEC / EN 61008-1 standards were considered. Important features are:

Up to date design

User-friendly connection of conductors and busbars

Resistance to current surges; unwanted tripping excluded

Simple and solid fixing to a 35 mm mounting rail in compliance with EN 60715

Additional colour display of main contacts position (red:contacts closed, green:contacts open)

5. Overall and mounting dimensions

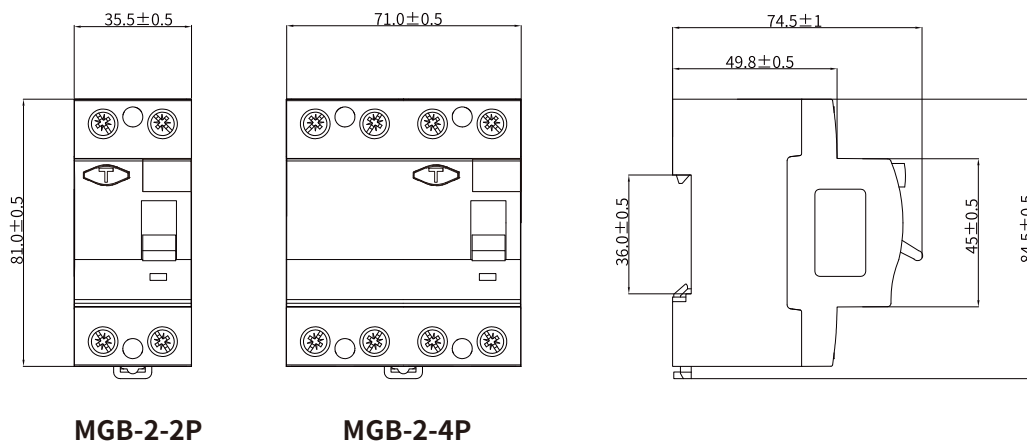

MGB-2-2P

MGB-2-4P

EPRi Series Residual Current Circuit Breaker

Technical data

Standard	EN/ IEC61008-1
Rated conditional short-circuit current, I_{nc}	6kA, 10kA
Protection	Ground fault
Rated current, I_n	25,32,40,63,80, 100, 125A
Number of poles	2(1+N),4(3+N)pole
Rated sensitivity currents, $I_{\Delta n}$	10,30, 100,300mA
Rated residual non-operating current	0.5 X $I_{\Delta n}$
Rated impulse withstand voltage U_{imp}	4kV
Rated voltages	2pole 240 VAC 4pole 415 VAC
Ambient temperature (°C)	-25~+40,Max. 95%humidity
Residual current off-time at $I_{\Delta n}$	≤0.1s
Rated residual current making & breaking capacity, $I_{\Delta m}$	500A for $I_n=16,25,32,40A$ 630A for $I_n=63A$ 800A for $I_n=80A$ 1000A for $I_n=100A$
Type of trip	Electro-magnetic release
Type of terminal	Lug type and Pin type
Terminal capacity	Cables up to 35mm ²
Protection degree	IP20
Installation	35mm DIN rail



Intertek

CE CB



EPRi-2P



EPRi-4P



EPRi RCD



EPRi-2P



EPRi-4P

Rated current(A)	$I_{\Delta n}$	Type AC 	Type A 	Packing unit
25	10mA	EPRi-2/25/10	EPRi-2/25/10-A	1
25		EPRi-2/25/30	EPRi-2/25/30-A	1
32	30mA	EPRi-2/32/30	EPRi-2/32/30-A	1
40		EPRi-2/40/30	EPRi-2/40/30-A	1
63		EPRi-2/63/30	EPRi-2/63/30-A	1
80		EPRi-2/80/30	EPRi-2/80/30-A	1
100		EPRi-2/100/30	EPRi-2/100/30-A	1
125		EPRi-2/125/30	EPRi-2/125/30-A	1
25	100mA	EPRi-2/25/100	EPRi-2/25/100-A	1
32		EPRi-2/32/100	EPRi-2/32/100-A	1
40		EPRi-2/40/100	EPRi-2/40/100-A	1
63		EPRi-2/63/100	EPRi-2/63/100-A	1
80		EPRi-2/80/100	EPRi-2/80/100-A	1
100		EPRi-2/100/100	EPRi-2/100/100-A	1
125		EPRi-2/125/100	EPRi-2/125/100-A	1
25	300mA	EPRi-2/25/300	EPRi-2/25/300-A	1
32		EPRi-2/32/300	EPRi-2/32/300-A	1
40		EPRi-2/40/300	EPRi-2/40/300-A	1
63		EPRi-2/63/300	EPRi-2/63/300-A	1
80		EPRi-2/80/300	EPRi-2/80/300-A	1
100		EPRi-2/100/300	EPRi-2/100/300-A	1
125		EPRi-2/125/300	EPRi-2/125/300-A	1
25	10mA	EPRi-4/25/10	EPRi-4/25/10-A	1
25		EPRi-4/25/30	EPRi-4/25/30-A	1
32	30mA	EPRi-4/32/30	EPRi-4/32/30-A	1
40		EPRi-4/40/30	EPRi-4/40/30-A	1
63		EPRi-4/63/30	EPRi-4/63/30-A	1
80		EPRi-4/80/30	EPRi-4/80/30-A	1
100		EPRi-4/100/30	EPRi-4/100/30-A	1
125		EPRi-4/125/30	EPRi-4/125/30-A	1
25	100mA	EPRi-4/25/100	EPRi-4/25/100-A	1
32		EPRi-4/32/100	EPRi-4/32/100-A	1
40		EPRi-4/40/100	EPRi-4/40/100-A	1
63		EPRi-4/63/100	EPRi-4/63/100-A	1
80		EPRi-4/80/100	EPRi-4/80/100-A	1
100		EPRi-4/100/100	EPRi-4/100/100-A	1
125		EPRi-4/125/100	EPRi-4/125/100-A	1
25	300mA	EPRi-4/25/300	EPRi-4/25/300-A	1
32		EPRi-4/32/300	EPRi-4/32/300-A	1
40		EPRi-4/40/300	EPRi-4/40/300-A	1
63		EPRi-4/63/300	EPRi-4/63/300-A	1
80		EPRi-4/80/300	EPRi-4/80/300-A	1
100		EPRi-4/100/300	EPRi-4/100/300-A	1
125		EPRi-4/125/300	EPRi-4/125/300-A	1

1. Life

In	Operating cycles		Operating frequency (operations/h)
	On-load operating cycles	Off-load operating cycles	
25,32	2000	2000	240
40,63,80,100,125	2000	1000	120

2. Breaking time of residual current

Max.breaking time					
In(A)	I Δ n(A)	I Δ n	2I Δ n	5I Δ n	5A,10A,20A,50A,100A,200A,500A
25,32,40,63,80,100,125	0.01,0.03,0.1,0.3	0.1s	0.08s	0.04s	0.04s

3. Wiring

The suitable conductors should be used for connection, see table below for relative parameters.

Rated current In (A)	Cross section area s (mm ²)	Tightening torque (N.m)
25	4	2.5
32	6	2.5
40	10	2.5
63	16	2.5
80	25	2.5
100	35	2.5
125	35	2.5

4. Features

When designing residual current devices, manufacturing technology and type of routine tests, the IEC / EN 61008-1 standards were considered. Important features are:

Up to date design

User-friendly connection of conductors and busbars

Resistance to current surges; unwanted tripping excluded

Simple and solid fixing to a 35 mm mounting rail in compliance with EN 60715

Additional colour display of main contacts position (red:contacts closed, green:contacts open)

5. Overall and mounting dimensions

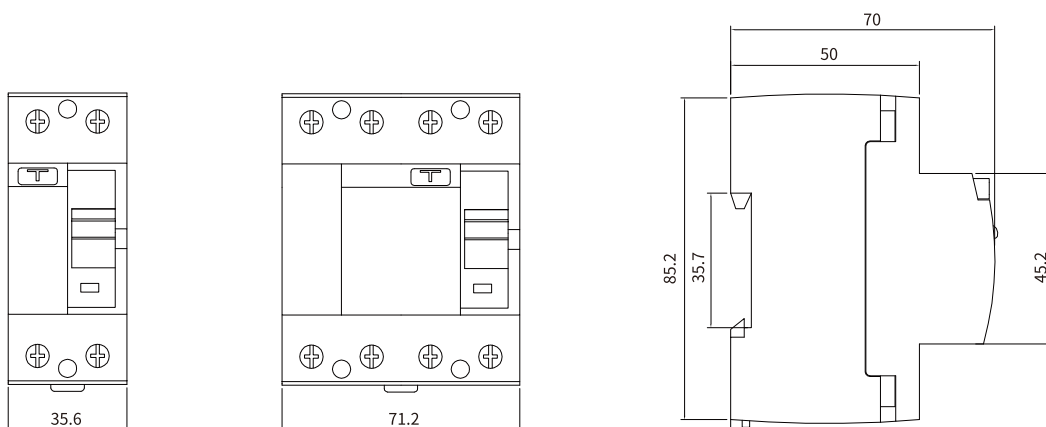

RCCB TYPE B EPRI-B Series

- High reliability
- Switched Neutral
- EV Charging & Solar PV Application
- Tripping Under AC, Pulsating & Smooth DC Currents
- Protection against direct/indirect contact



Committed to becoming a world-class intelligent electric brand

EPRi-B Series

Residual Current Circuit Breaker

Technical data





Standard	EN/ IEC62423
Rated conditional short-circuit current, I_{nc}	6kA/10kA
Protection	Ground fault
Rated current, I_n	16,25,32,40,50,63A
Number of poles	2(1+N),4(3+N)pole
Rated sensitivity currents, $I_{\Delta n}$	30, 100,300mA
Rated residual non-operating current	$0.5 \times I_{\Delta n}$
Rated impulse withstand voltage U_{imp}	4kV
Rated voltages 2pole	230/240VAC
4pole	400/415VAC
Ambient temperature ($^{\circ}C$)	-25~+40,Max. 95%humidity
Residual current off-time at $I_{\Delta n}$	$\leq 0.1s$
Rated residual current making & breaking capacity, $I_{\Delta m}$	500A for $I_n=16,25,32,40A$ 630A for $I_n=63A$
Type of trip	Electro-magnetic release
Type of terminal	Lug type and Pin type
Terminal capacity	Cables up to $35mm^2$
Protection degree	IP20
Installation	35mm DIN rail



EPRi-B-2P



EPRi-B-4P

EPRI-B RCD	Rated current(A)	$I_{\Delta n}$	B Type   	Packing unit
	16	30mA	EPRI-B/2/16/30	1
	25		EPRI-B/2/25/30	1
	32		EPRI-B/2/32/30	1
	40		EPRI-B/2/40/30	1
	50		EPRI-B/2/50/30	1
	63		EPRI-B/2/63/30	1
	16	100mA	EPRI-B/2/16/100	1
	25		EPRI-B/2/25/100	1
	32		EPRI-B/2/32/100	1
	40		EPRI-B/2/40/100	1
	50		EPRI-B/2/50/100	1
	63		EPRI-B/2/63/100	1
	16	300mA	EPRI-B/2/16/300	1
	25		EPRI-B/2/25/300	1
	32		EPRI-B/2/32/300	1
	40		EPRI-B/2/40/300	1
	50		EPRI-B/2/50/300	1
	63		EPRI-B/2/63/300	1
	16	30mA	EPRI-B/4/16/30	1
	25		EPRI-B/4/25/30	1
	32		EPRI-B/4/32/30	1
	40		EPRI-B/4/40/30	1
	50		EPRI-B/4/50/30	1
	63		EPRI-B/4/63/30	1
	16	100mA	EPRI-B/4/16/100	1
	25		EPRI-B/4/25/100	1
	32		EPRI-B/4/32/100	1
	40		EPRI-B/4/40/100	1
	50		EPRI-B/4/50/100	1
	63		EPRI-B/4/63/100	1
	16	300mA	EPRI-B/4/16/300	1
	25		EPRI-B/4/25/300	1
	32		EPRI-B/4/32/300	1
	40		EPRI-B/4/40/300	1
	50		EPRI-B/4/50/300	1
	63		EPRI-B/4/63/300	1

EPRI-B-2P

EPRI-B-4P

1. Life

In	Operating cycles		Operating frequency (operations/h)
	On-load operating cycles	Off-load operating cycles	
16,25,32	2000	2000	240
40,50,63	2000	1000	120

2. Breaking time of residual current

Max.breaking time					
In(A)	I Δ n(A)	I Δ n	2I Δ n	5I Δ n	5A,10A,20A,50A,100A,200A,500A
16,25,32,40,50,63	0.03,0.1,0.3	0.1s	0.08s	0.04s	0.04s

3. Wiring

The suitable conductors should be used for connection, see table below for relative parameters.

Rated current In (A)	Nominal cross section area s(mm) ²	Tightening torque (N.m)
16	4	2.5
25	4	2.5
32	6	2.5
40	10	2.5
50	16	2.5
63	16	2.5

4. Features

When designing residual current devices, manufacturing technology and type of routine tests, the IEC / EN 62423 standards were considered. Important features are:

Up to date design

User-friendly connection of conductors and busbars

Resistance to current surges; unwanted tripping excluded

Simple and solid fixing to a 35 mm mounting rail

Additional colour display of main contacts position (red:contacts closed, green:contacts open)

5. Overall and mounting dimensions

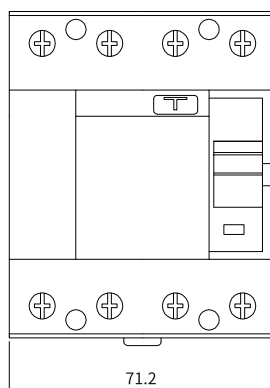
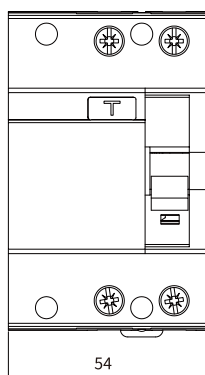

EPRi-B

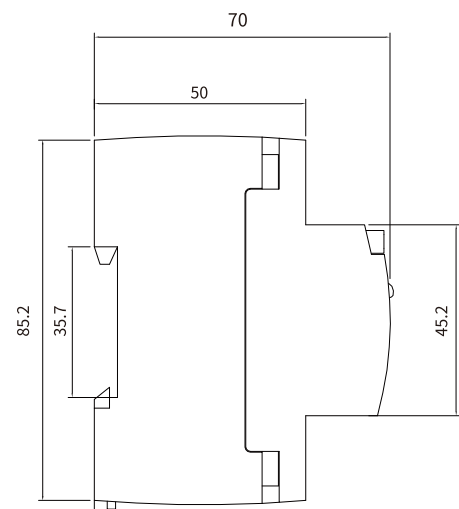

EPBRi Series (Electronic) Residual Current Operated Circuit Breaker(RCBO)

Technical data

Standard	EN/ IEC61009-1
Breaking Capacity	6kA,10kA
Number of poles	1 P+N(1 module)
Rated current,In	6, 10, 13,16, 20, 25, 32, 40A
Rated voltage	240VAC
Rated Tripping Current	10,30,100,300mA
Residual current off time	≤0.1s
Characteristic	B,C Curve
Electrical endurance	4000
Mechanical endurance	10000
Ambient temperature (°C)	-25~+40, Max. 95%humidity
Connection terminal	Flexible conductor 16mm ² Rigid conductor 25mm ²
Type of terminal	Lug type and Pin type
Width	17.8mm









Intertek





EPBRi-6K



EPBRi-10K

EPBri-6K RCBO	Rated current(A)	$I_{\Delta n}$	Type AC 		Type A 		Packing unit
			B curve	C curve	B curve	C curve	
	6	10mA	EPBri-6K/B6/10	EPBri-6K/C6/10	EPBri-6K/B6/10-A	EPBri-6K/C6/10-A	5
	10		EPBri-6K/B10/10	EPBri-6K/C10/10	EPBri-6K/B10/10-A	EPBri-6K/C10/10-A	5
	13		EPBri-6K/B13/10	EPBri-6K/C13/10	EPBri-6K/B13/10-A	EPBri-6K/C13/10-A	5
	16		EPBri-6K/B16/10	EPBri-6K/C16/10	EPBri-6K/B16/10-A	EPBri-6K/C16/10-A	5
	20		EPBri-6K/B20/10	EPBri-6K/C20/10	EPBri-6K/B20/10-A	EPBri-6K/C20/10-A	5
	25		EPBri-6K/B25/10	EPBri-6K/C25/10	EPBri-6K/B25/10-A	EPBri-6K/C25/10-A	5
	32		EPBri-6K/B32/10	EPBri-6K/C32/10	EPBri-6K/B32/10-A	EPBri-6K/C32/10-A	5
	40		EPBri-6K/B40/10	EPBri-6K/C40/10	EPBri-6K/B40/10-A	EPBri-6K/C40/10-A	5
	6	30mA	EPBri-6K/B6/30	EPBri-6K/C6/30	EPBri-6K/B6/30-A	EPBri-6K/C6/30-A	5
	10		EPBri-6K/B10/30	EPBri-6K/C10/30	EPBri-6K/B10/30-A	EPBri-6K/C10/30-A	5
	13		EPBri-6K/B13/30	EPBri-6K/C13/30	EPBri-6K/B13/30-A	EPBri-6K/C13/30-A	5
	16		EPBri-6K/B16/30	EPBri-6K/C16/30	EPBri-6K/B16/30-A	EPBri-6K/C16/30-A	5
	20		EPBri-6K/B20/30	EPBri-6K/C20/30	EPBri-6K/B20/30-A	EPBri-6K/C20/30-A	5
	25		EPBri-6K/B25/30	EPBri-6K/C25/30	EPBri-6K/B25/30-A	EPBri-6K/C25/30-A	5
	32		EPBri-6K/B32/30	EPBri-6K/C32/30	EPBri-6K/B32/30-A	EPBri-6K/C32/30-A	5
	40		EPBri-6K/B40/30	EPBri-6K/C40/30	EPBri-6K/B40/30-A	EPBri-6K/C40/30-A	5
	6	100mA	EPBri-6K/B6/100	EPBri-6K/C6/100	EPBri-6K/B6/100-A	EPBri-6K/C6/100-A	5
	10		EPBri-6K/B10/100	EPBri-6K/C10/100	EPBri-6K/B10/100-A	EPBri-6K/C10/100-A	5
	13		EPBri-6K/B13/100	EPBri-6K/C13/100	EPBri-6K/B13/100-A	EPBri-6K/C13/100-A	5
	16		EPBri-6K/B16/100	EPBri-6K/C16/100	EPBri-6K/B16/100-A	EPBri-6K/C16/100-A	5
	20		EPBri-6K/B20/100	EPBri-6K/C20/100	EPBri-6K/B20/100-A	EPBri-6K/C20/100-A	5
	25		EPBri-6K/B25/100	EPBri-6K/C25/100	EPBri-6K/B25/100-A	EPBri-6K/C25/100-A	5
	32		EPBri-6K/B32/100	EPBri-6K/C32/100	EPBri-6K/B32/100-A	EPBri-6K/C32/100-A	5
	40		EPBri-6K/B40/100	EPBri-6K/C40/100	EPBri-6K/B40/100-A	EPBri-6K/C40/100-A	5
	6	300mA	EPBri-6K/B6/300	EPBri-6K/C6/300	EPBri-6K/B6/300-A	EPBri-6K/C6/300-A	5
	10		EPBri-6K/B10/300	EPBri-6K/C10/300	EPBri-6K/B10/300-A	EPBri-6K/C10/300-A	5
	13		EPBri-6K/B13/300	EPBri-6K/C13/300	EPBri-6K/B13/300-A	EPBri-6K/C13/300-A	5
	16		EPBri-6K/B16/300	EPBri-6K/C16/300	EPBri-6K/B16/300-A	EPBri-6K/C16/300-A	5
	20		EPBri-6K/B20/300	EPBri-6K/C20/300	EPBri-6K/B20/300-A	EPBri-6K/C20/300-A	5
	25		EPBri-6K/B25/300	EPBri-6K/C25/300	EPBri-6K/B25/300-A	EPBri-6K/C25/300-A	5
	32		EPBri-6K/B32/300	EPBri-6K/C32/300	EPBri-6K/B32/300-A	EPBri-6K/C32/300-A	5
	40		EPBri-6K/B40/300	EPBri-6K/C40/300	EPBri-6K/B40/300-A	EPBri-6K/C40/300-A	5

EPBRi-10K RCBO	Rated current(A)	$I_{\Delta n}$	Type AC 		Type A 		Packing unit	
			B curve	C curve	B curve	C curve		
	6	10mA	EPBRi-10K/B6/10	EPBRi-10K/C6/10	EPBRi-10K/B6/10-A	EPBRi-10K/C6/10-A	5	
	10		EPBRi-10K/B10/10	EPBRi-10K/C10/10	EPBRi-10K/B10/10-A	EPBRi-10K/C10/10-A	5	
	13		EPBRi-10K/B13/10	EPBRi-10K/C13/10	EPBRi-10K/B13/10-A	EPBRi-10K/C13/10-A	5	
	16		EPBRi-10K/B16/10	EPBRi-10K/C16/10	EPBRi-10K/B16/10-A	EPBRi-10K/C16/10-A	5	
	20		EPBRi-10K/B20/10	EPBRi-10K/C20/10	EPBRi-10K/B20/10-A	EPBRi-10K/C20/10-A	5	
	25		EPBRi-10K/B25/10	EPBRi-10K/C25/10	EPBRi-10K/B25/10-A	EPBRi-10K/C25/10-A	5	
	32		EPBRi-10K/B32/10	EPBRi-10K/C32/10	EPBRi-10K/B32/10-A	EPBRi-10K/C32/10-A	5	
	40		EPBRi-10K/B40/10	EPBRi-10K/C40/10	EPBRi-10K/B40/10-A	EPBRi-10K/C40/10-A	5	
	6		30mA	EPBRi-10K/B6/30	EPBRi-10K/C6/30	EPBRi-10K/B6/30-A	EPBRi-10K/C6/30-A	5
	10			EPBRi-10K/B10/30	EPBRi-10K/C10/30	EPBRi-10K/B10/30-A	EPBRi-10K/C10/30-A	5
13	EPBRi-10K/B13/30	EPBRi-10K/C13/30		EPBRi-10K/B13/30-A	EPBRi-10K/C13/30-A	5		
16	EPBRi-10K/B16/30	EPBRi-10K/C16/30		EPBRi-10K/B16/30-A	EPBRi-10K/C16/30-A	5		
20	EPBRi-10K/B20/30	EPBRi-10K/C20/30		EPBRi-10K/B20/30-A	EPBRi-10K/C20/30-A	5		
25	EPBRi-10K/B25/30	EPBRi-10K/C25/30		EPBRi-10K/B25/30-A	EPBRi-10K/C25/30-A	5		
32	EPBRi-10K/B32/30	EPBRi-10K/C32/30		EPBRi-10K/B32/30-A	EPBRi-10K/C32/30-A	5		
40	EPBRi-10K/B40/30	EPBRi-10K/C40/30		EPBRi-10K/B40/30-A	EPBRi-10K/C40/30-A	5		
6	100mA	EPBRi-10K/B6/100		EPBRi-10K/C6/100	EPBRi-10K/B6/100-A	EPBRi-10K/C6/100-A	5	
10		EPBRi-10K/B10/100		EPBRi-10K/C10/100	EPBRi-10K/B10/100-A	EPBRi-10K/C10/100-A	5	
13		EPBRi-10K/B13/100	EPBRi-10K/C13/100	EPBRi-10K/B13/100-A	EPBRi-10K/C13/100-A	5		
16		EPBRi-10K/B16/100	EPBRi-10K/C16/100	EPBRi-10K/B16/100-A	EPBRi-10K/C16/100-A	5		
20		EPBRi-10K/B20/100	EPBRi-10K/C20/100	EPBRi-10K/B20/100-A	EPBRi-10K/C20/100-A	5		
25		EPBRi-10K/B25/100	EPBRi-10K/C25/100	EPBRi-10K/B25/100-A	EPBRi-10K/C25/100-A	5		
32		EPBRi-10K/B32/100	EPBRi-10K/C32/100	EPBRi-10K/B32/100-A	EPBRi-10K/C32/100-A	5		
40		EPBRi-10K/B40/100	EPBRi-10K/C40/100	EPBRi-10K/B40/100-A	EPBRi-10K/C40/100-A	5		
6		300mA	EPBRi-10K/B6/300	EPBRi-10K/C6/300	EPBRi-10K/B6/300-A	EPBRi-10K/C6/300-A	5	
10			EPBRi-10K/B10/300	EPBRi-10K/C10/300	EPBRi-10K/B10/300-A	EPBRi-10K/C10/300-A	5	
13	EPBRi-10K/B13/300		EPBRi-10K/C13/300	EPBRi-10K/B13/300-A	EPBRi-10K/C13/300-A	5		
16	EPBRi-10K/B16/300		EPBRi-10K/C16/300	EPBRi-10K/B16/300-A	EPBRi-10K/C16/300-A	5		
20	EPBRi-10K/B20/300		EPBRi-10K/C20/300	EPBRi-10K/B20/300-A	EPBRi-10K/C20/300-A	5		
25	EPBRi-10K/B25/300		EPBRi-10K/C25/300	EPBRi-10K/B25/300-A	EPBRi-10K/C25/300-A	5		
32	EPBRi-10K/B32/300		EPBRi-10K/C32/300	EPBRi-10K/B32/300-A	EPBRi-10K/C32/300-A	5		
40	EPBRi-10K/B40/300		EPBRi-10K/C40/300	EPBRi-10K/B40/300-A	EPBRi-10K/C40/300-A	5		

Type AC 

Type A 



EPBR-W Series (Electronic) Residual Current Operated Circuit Breaker(RCBO)

Technical data

Standard	EN/ IEC61009-1
Breaking Capacity	6kA,10kA
Number of poles	1 P+N(1module)
Rated current,In	6, 10, 16, 20, 25, 32, 40A
Rated voltage	240VAC
Rated Tripping Current	10,30,100,300mA
Residual current off time	≤0.1s
Characteristic	B,C Curve
Electrical endurance	4000
Mechanical endurance	10000
Ambient temperature (°C)	-25~+40, Max. 95%humidity
Connection terminal	Flexible conductor 16mm ² Rigid conductor 25mm ²
Type of terminal	Lug type and Pin type
Width	25mm



EPBR-w

EPBR6K-w RCBO	Rated current(A)	$I_{\Delta n}$	Type AC 		Type A 		Packing unit
			B curve	C curve	B curve	C curve	
	6	10mA	EPBR6K-w/B6/10	EPBR6K-w/C6/10	EPBR6K-w/B6/10-A	EPBR6K-w/C6/10-A	5
	10		EPBR6K-w/B10/10	EPBR6K-w/C10/10	EPBR6K-w/B10/10-A	EPBR6K-w/C10/10-A	5
	16		EPBR6K-w/B16/10	EPBR6K-w/C16/10	EPBR6K-w/B16/10-A	EPBR6K-w/C16/10-A	5
	20		EPBR6K-w/B20/10	EPBR6K-w/C20/10	EPBR6K-w/B20/10-A	EPBR6K-w/C20/10-A	5
	25		EPBR6K-w/B25/10	EPBR6K-w/C25/10	EPBR6K-w/B25/10-A	EPBR6K-w/C25/10-A	5
	32		EPBR6K-w/B32/10	EPBR6K-w/C32/10	EPBR6K-w/B32/10-A	EPBR6K-w/C32/10-A	5
	40		EPBR6K-w/B40/10	EPBR6K-w/C40/10	EPBR6K-w/B40/10-A	EPBR6K-w/C40/10-A	5
	6		30mA	EPBR6K-w/B6/30	EPBR6K-w/C6/30	EPBR6K-w/B6/30-A	EPBR6K-w/C6/30-A
	10	EPBR6K-w/B10/30		EPBR6K-w/C10/30	EPBR6K-w/B10/30-A	EPBR6K-w/C10/30-A	5
	16	EPBR6K-w/B16/30		EPBR6K-w/C16/30	EPBR6K-w/B16/30-A	EPBR6K-w/C16/30-A	5
	20	EPBR6K-w/B20/30		EPBR6K-w/C20/30	EPBR6K-w/B20/30-A	EPBR6K-w/C20/30-A	5
	25	EPBR6K-w/B25/30		EPBR6K-w/C25/30	EPBR6K-w/B25/30-A	EPBR6K-w/C25/30-A	5
	32	EPBR6K-w/B32/30		EPBR6K-w/C32/30	EPBR6K-w/B32/30-A	EPBR6K-w/C32/30-A	5
	40	EPBR6K-w/B40/30		EPBR6K-w/C40/30	EPBR6K-w/B40/30-A	EPBR6K-w/C40/30-A	5
	6	100mA		EPBR6K-w/B6/100	EPBR6K-w/C6/100	EPBR6K-w/B6/100-A	EPBR6K-w/C6/100-A
	10		EPBR6K-w/B10/100	EPBR6K-w/C10/100	EPBR6K-w/B10/100-A	EPBR6K-w/C10/100-A	5
	16		EPBR6K-w/B16/100	EPBR6K-w/C16/100	EPBR6K-w/B16/100-A	EPBR6K-w/C16/100-A	5
	20		EPBR6K-w/B20/100	EPBR6K-w/C20/100	EPBR6K-w/B20/100-A	EPBR6K-w/C20/100-A	5
	25		EPBR6K-w/B25/100	EPBR6K-w/C25/100	EPBR6K-w/B25/100-A	EPBR6K-w/C25/100-A	5
	32		EPBR6K-w/B32/100	EPBR6K-w/C32/100	EPBR6K-w/B32/100-A	EPBR6K-w/C32/100-A	5
	40		EPBR6K-w/B40/100	EPBR6K-w/C40/100	EPBR6K-w/B40/100-A	EPBR6K-w/C40/100-A	5
	6		300mA	EPBR6K-w/B6/300	EPBR6K-w/C6/300	EPBR6K-w/B6/300-A	EPBR6K-w/C6/300-A
	10	EPBR6K-w/B10/300		EPBR6K-w/C10/300	EPBR6K-w/B10/300-A	EPBR6K-w/C10/300-A	5
	16	EPBR6K-w/B16/300		EPBR6K-w/C16/300	EPBR6K-w/B16/300-A	EPBR6K-w/C16/300-A	5
	20	EPBR6K-w/B20/300		EPBR6K-w/C20/300	EPBR6K-w/B20/300-A	EPBR6K-w/C20/300-A	5
	25	EPBR6K-w/B25/300		EPBR6K-w/C25/300	EPBR6K-w/B25/300-A	EPBR6K-w/C25/300-A	5
	32	EPBR6K-w/B32/300		EPBR6K-w/C32/300	EPBR6K-w/B32/300-A	EPBR6K-w/C32/300-A	5
	40	EPBR6K-w/B40/300		EPBR6K-w/C40/300	EPBR6K-w/B40/300-A	EPBR6K-w/C40/300-A	5



EPBR6K-w

1. Curves

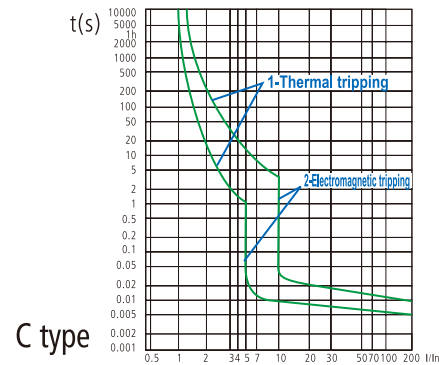
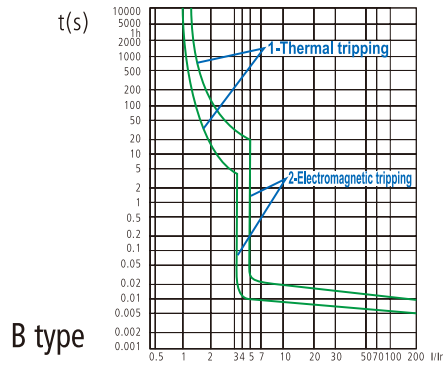

2. Breaking time of residual current

In(A)	I Δ n(A)	Max.breaking time			
		I Δ n	2I Δ n	5I Δ n	5A,10A,20A,50A,100A,200A,500A
6-40	0.01,0.03,0.1,0.3	0.1s	0.08s	0.04s	0.04s

3. Wiring

The suitable conductors should be used for connection, see table below for relative parameters.

Rated current In (A)	Cross section area s (mm ²)	Tightening torque (N.m)
6	1	2
10	1.5	2
16-20	2.5	2
25	4	2
32	6	2
40	10	2

4. Features

- Switching and isolation function.
- Protection against overload and short-circuit currents.
- Protection against the effects of sinusoidal alternating earth fault currents.
- Protection against indirect contacts and additional protection against direct contacts.
- Protection against fire hazard caused by insulation faults.
- Used in residential building and distribution boards.

5. Overall and mounting dimensions

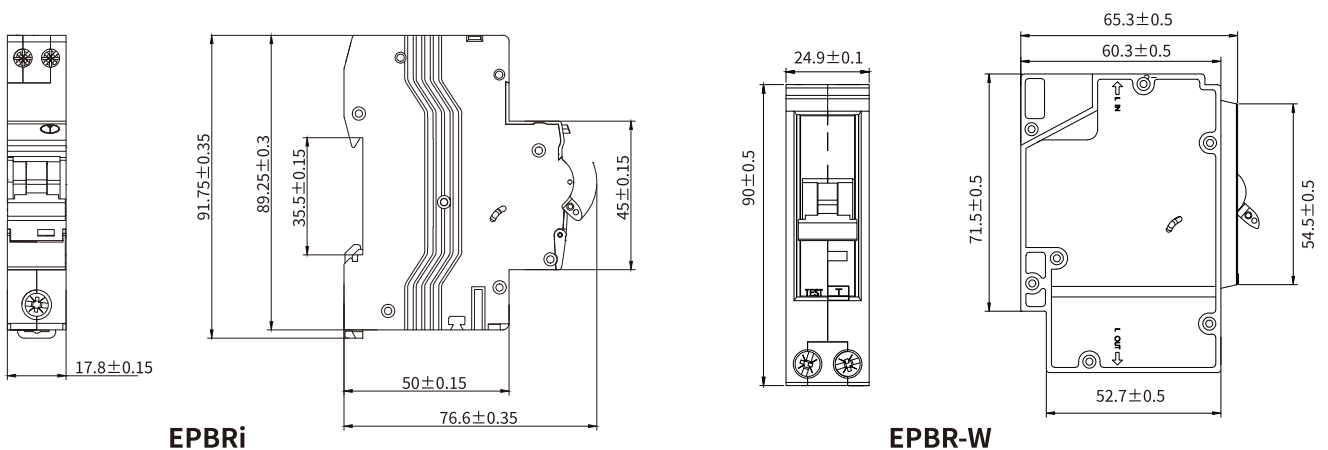

MGR-63H/M Series

(Electronic/Electro-magnetic)
Residual Current Operated Circuit Breaker(RCBO)

Technical data

Standard	EN/IEC61009-1	
Breaking capacity	6kA,10kA	
Protection	Ground fault, overcurrent and short circuit	
Rated current, I_n	6,10,13,16,20,25,32,40,50,63A	
Operating, I_{Δn}	10,30,100,300mA	
Characteristic	B,C Curve	
Rated residual current operated making & breaking capacity I_{Δm}	500A	
Rated residual non-operated current I_{Δn}	0.5I _{Δn}	
Rated impulse withstand voltage U_{imp}	4kV	
Number of poles	1P+N	
Rated voltages 2pole	240VAC	
Ambient temperature (°C)	-25~+40,Max.95% humidity	
Residual current off-time	≤0.1 sec	
Type of trip	Ground fault	Electronic/Electro-magnetic
	Over current	Thermal-magnetic
Protection degree	IP20	
Terminal capacity	16mm ² flexible/25mm ² rigid	
Installation	35mm DIN rail	
Width	2 modules	
Type of terminal	Lug type and Pin type	



MGR-63M



MGR-63H

MGR-63M-RCBO









Type AC



Type A



Rated current(A)	I _{Δn}	Type AC		Type A		Packing unit
		B curve	C curve	B curve	C curve	
6	10mA	MGR-63M-B6/10	MGR-63M-C6/10	MGR-63M-B6/10-A	MGR-63M-C6/10-A	6
10		MGR-63M-B10/10	MGR-63M-C10/10	MGR-63M-B10/10-A	MGR-63M-C10/10-A	
13		MGR-63M-B13/10	MGR-63M-C13/10	MGR-63M-B13/10-A	MGR-63M-C13/10-A	
16		MGR-63M-B16/10	MGR-63M-C16/10	MGR-63M-B16/10-A	MGR-63M-C16/10-A	
20		MGR-63M-B20/10	MGR-63M-C20/10	MGR-63M-B20/10-A	MGR-63M-C20/10-A	
25		MGR-63M-B25/10	MGR-63M-C25/10	MGR-63M-B25/10-A	MGR-63M-C25/10-A	
32		MGR-63M-B32/10	MGR-63M-C32/10	MGR-63M-B32/10-A	MGR-63M-C32/10-A	
40		MGR-63M-B40/10	MGR-63M-C40/10	MGR-63M-B40/10-A	MGR-63M-C40/10-A	
50		MGR-63M-B50/10	MGR-63M-C50/10	MGR-63M-B50/10-A	MGR-63M-C50/10-A	
63		MGR-63M-B63/10	MGR-63M-C63/10	MGR-63M-B63/10-A	MGR-63M-C63/10-A	
6	30mA	MGR-63M-B6/30	MGR-63M-C6/30	MGR-63M-B6/30-A	MGR-63M-C30/10-A	6
10		MGR-63M-B10/30	MGR-63M-C10/30	MGR-63M-B10/30-A	MGR-63M-C30/10-A	
13		MGR-63M-B13/30	MGR-63M-C13/30	MGR-63M-B13/30-A	MGR-63M-C30/10-A	
16		MGR-63M-B16/30	MGR-63M-C16/30	MGR-63M-B16/30-A	MGR-63M-C30/10-A	
20		MGR-63M-B20/30	MGR-63M-C20/30	MGR-63M-B20/30-A	MGR-63M-C30/10-A	
25		MGR-63M-B25/30	MGR-63M-C25/30	MGR-63M-B25/30-A	MGR-63M-C30/10-A	
32		MGR-63M-B32/30	MGR-63M-C32/30	MGR-63M-B32/30-A	MGR-63M-C30/10-A	
40		MGR-63M-B40/30	MGR-63M-C40/30	MGR-63M-B40/30-A	MGR-63M-C30/10-A	
50		MGR-63M-B50/30	MGR-63M-C50/30	MGR-63M-B50/30-A	MGR-63M-C30/10-A	
63		MGR-63M-B63/30	MGR-63M-C63/30	MGR-63M-B63/30-A	MGR-63M-C30/10-A	
6	100mA	MGR-63M-B6/100	MGR-63M-C6/100	MGR-63M-B6/100-A	MGR-63M-C6/100-A	6
10		MGR-63M-B10/100	MGR-63M-C10/100	MGR-63M-B10/100-A	MGR-63M-C10/100-A	
13		MGR-63M-B13/100	MGR-63M-C13/100	MGR-63M-B13/100-A	MGR-63M-C13/100-A	
16		MGR-63M-B16/100	MGR-63M-C16/100	MGR-63M-B16/100-A	MGR-63M-C16/100-A	
20		MGR-63M-B20/100	MGR-63M-C20/100	MGR-63M-B20/100-A	MGR-63M-C20/100-A	
25		MGR-63M-B25/100	MGR-63M-C25/100	MGR-63M-B25/100-A	MGR-63M-C25/100-A	
32		MGR-63M-B32/100	MGR-63M-C32/100	MGR-63M-B32/100-A	MGR-63M-C32/100-A	
40		MGR-63M-B40/100	MGR-63M-C40/100	MGR-63M-B40/100-A	MGR-63M-C40/100-A	
50		MGR-63M-B50/100	MGR-63M-C50/100	MGR-63M-B50/100-A	MGR-63M-C50/100-A	
63		MGR-63M-B63/100	MGR-63M-C63/100	MGR-63M-B63/100-A	MGR-63M-C63/100-A	
6	300mA	MGR-63M-B6/300	MGR-63M-C6/300	MGR-63M-B6/300-A	MGR-63M-C6/300-A	6
10		MGR-63M-B10/300	MGR-63M-C10/300	MGR-63M-B10/300-A	MGR-63M-C10/300-A	
13		MGR-63M-B13/300	MGR-63M-C13/300	MGR-63M-B13/300-A	MGR-63M-C13/300-A	
16		MGR-63M-B16/300	MGR-63M-C16/300	MGR-63M-B16/300-A	MGR-63M-C16/300-A	
20		MGR-63M-B20/300	MGR-63M-C20/300	MGR-63M-B20/300-A	MGR-63M-C20/300-A	
25		MGR-63M-B25/300	MGR-63M-C25/300	MGR-63M-B25/300-A	MGR-63M-C25/300-A	
32		MGR-63M-B32/300	MGR-63M-C32/300	MGR-63M-B32/300-A	MGR-63M-C32/300-A	
40		MGR-63M-B40/300	MGR-63M-C40/300	MGR-63M-B40/300-A	MGR-63M-C40/300-A	
50		MGR-63M-B50/300	MGR-63M-C50/300	MGR-63M-B50/300-A	MGR-63M-C50/300-A	
63		MGR-63M-B63/300	MGR-63M-C63/300	MGR-63M-B63/300-A	MGR-63M-C63/300-A	

MGR-63H-RCBO	Rated current(A)	I _{Δn}	Type AC 		Type A 		Packing unit
			B curve	C curve	B curve	C curve	
	6	10mA	MGR-63H-B6/10	MGR-63H-C6/10	MGR-63H-B6/10-A	MGR-63H-C6/10-A	6
	10		MGR-63H-B10/10	MGR-63H-C10/10	MGR-63H-B10/10-A	MGR-63H-C10/10-A	
	13		MGR-63H-B13/10	MGR-63H-C13/10	MGR-63H-B13/10-A	MGR-63H-C13/10-A	
	16		MGR-63H-B16/10	MGR-63H-C16/10	MGR-63H-B16/10-A	MGR-63H-C16/10-A	
	20		MGR-63H-B20/10	MGR-63H-C20/10	MGR-63H-B20/10-A	MGR-63H-C20/10-A	
	25		MGR-63H-B25/10	MGR-63H-C25/10	MGR-63H-B25/10-A	MGR-63H-C25/10-A	
	32		MGR-63H-B32/10	MGR-63H-C32/10	MGR-63H-B32/10-A	MGR-63H-C32/10-A	
	40		MGR-63H-B40/10	MGR-63H-C40/10	MGR-63H-B40/10-A	MGR-63H-C40/10-A	
	50		MGR-63H-B50/10	MGR-63H-C50/10	MGR-63H-B50/10-A	MGR-63H-C50/10-A	
	63		MGR-63H-B63/10	MGR-63H-C63/10	MGR-63H-B63/10-A	MGR-63H-C63/10-A	
	6	30mA	MGR-63H-B6/30	MGR-63H-C6/30	MGR-63H-B6/30-A	MGR-63H-C30/10-A	6
	10		MGR-63H-B10/30	MGR-63H-C10/30	MGR-63H-B10/30-A	MGR-63H-C30/10-A	
	13		MGR-63H-B13/30	MGR-63H-C13/30	MGR-63H-B13/30-A	MGR-63H-C30/10-A	
	16		MGR-63H-B16/30	MGR-63H-C16/30	MGR-63H-B16/30-A	MGR-63H-C30/10-A	
	20		MGR-63H-B20/30	MGR-63H-C20/30	MGR-63H-B20/30-A	MGR-63H-C30/10-A	
	25		MGR-63H-B25/30	MGR-63H-C25/30	MGR-63H-B25/30-A	MGR-63H-C30/10-A	
	32		MGR-63H-B32/30	MGR-63H-C32/30	MGR-63H-B32/30-A	MGR-63H-C30/10-A	
	40		MGR-63H-B40/30	MGR-63H-C40/30	MGR-63H-B40/30-A	MGR-63H-C30/10-A	
	50		MGR-63H-B50/30	MGR-63H-C50/30	MGR-63H-B50/30-A	MGR-63H-C30/10-A	
	63		MGR-63H-B63/30	MGR-63H-C63/30	MGR-63H-B63/30-A	MGR-63H-C30/10-A	
	6	100mA	MGR-63H-B6/100	MGR-63H-C6/100	MGR-63H-B6/100-A	MGR-63H-C6/100-A	6
	10		MGR-63H-B10/100	MGR-63H-C10/100	MGR-63H-B10/100-A	MGR-63H-C10/100-A	
	13		MGR-63H-B13/100	MGR-63H-C13/100	MGR-63H-B13/100-A	MGR-63H-C13/100-A	
	16		MGR-63H-B16/100	MGR-63H-C16/100	MGR-63H-B16/100-A	MGR-63H-C16/100-A	
	20		MGR-63H-B20/100	MGR-63H-C20/100	MGR-63H-B20/100-A	MGR-63H-C20/100-A	
	25		MGR-63H-B25/100	MGR-63H-C25/100	MGR-63H-B25/100-A	MGR-63H-C25/100-A	
	32		MGR-63H-B32/100	MGR-63H-C32/100	MGR-63H-B32/100-A	MGR-63H-C32/100-A	
	40		MGR-63H-B40/100	MGR-63H-C40/100	MGR-63H-B40/100-A	MGR-63H-C40/100-A	
	50		MGR-63H-B50/100	MGR-63H-C50/100	MGR-63H-B50/100-A	MGR-63H-C50/100-A	
	63		MGR-63H-B63/100	MGR-63H-C63/100	MGR-63H-B63/100-A	MGR-63H-C63/100-A	
	6	300mA	MGR-63H-B6/300	MGR-63H-C6/300	MGR-63H-B6/300-A	MGR-63H-C6/300-A	6
	10		MGR-63H-B10/300	MGR-63H-C10/300	MGR-63H-B10/300-A	MGR-63H-C10/300-A	
	13		MGR-63H-B13/300	MGR-63H-C13/300	MGR-63H-B13/300-A	MGR-63H-C13/300-A	
	16		MGR-63H-B16/300	MGR-63H-C16/300	MGR-63H-B16/300-A	MGR-63H-C16/300-A	
	20		MGR-63H-B20/300	MGR-63H-C20/300	MGR-63H-B20/300-A	MGR-63H-C20/300-A	
	25		MGR-63H-B25/300	MGR-63H-C25/300	MGR-63H-B25/300-A	MGR-63H-C25/300-A	
	32		MGR-63H-B32/300	MGR-63H-C32/300	MGR-63H-B32/300-A	MGR-63H-C32/300-A	
	40		MGR-63H-B40/300	MGR-63H-C40/300	MGR-63H-B40/300-A	MGR-63H-C40/300-A	
	50		MGR-63H-B50/300	MGR-63H-C50/300	MGR-63H-B50/300-A	MGR-63H-C50/300-A	
	63		MGR-63H-B63/300	MGR-63H-C63/300	MGR-63H-B63/300-A	MGR-63H-C63/300-A	

Type AC



Type A



1. Curves

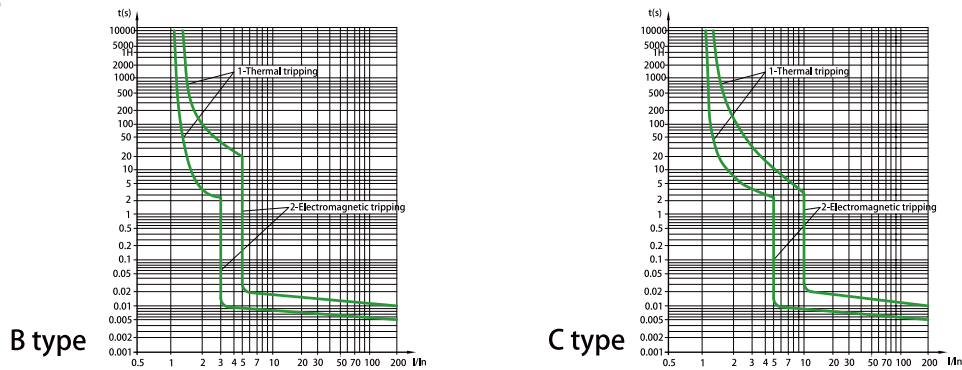

2. Wiring

The suitable conductors should be used for connection, see table below for relative parameters.

Rated current In (A)	Cross section area s (mm ²)	Tightening torque (N.m)
6	1	2
10	1.5	2
13	1.5	2
16-20	2.5	2
25	4	2
32	6	2
40	10	2
63	16	2

3. Types

Both RCCBs and RCBOs are divided into types depending on the operating function:

Type AC : For which tripping is ensured for residual sinusoidal alternating currents, whether suddenly applied or slowly rising.

Type A : For which tripping is ensured for residual sinusoidal alternating currents and residual pulsating direct currents, whether suddenly applied or slowly rising.

4. Tripping sensitivity data

RCD with a rated residual current of maximum 30mA are used for personnel, material and fire protection, as well as for protection against direct contact.

RCD with a rated residual current of maximum 300mA are used as preventative fire protection in case of insulation faults. RCD with a rated residual current of 100mA co-ordinated with the earth system according to the formula $I\Delta n < 50/R$, to provide protection against indirect contacts.

5. Overall and mounting dimensions

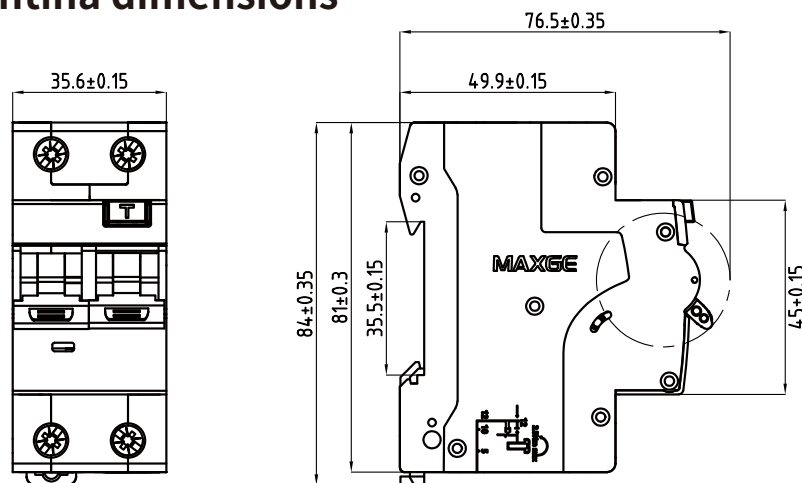

MGR-63M/H

MGRN-32M/H Series (Electronic)

Residual Current Operated Circuit Breaker(RCBO)

Technical data

Standard	EN/IEC61009-1
Breaking Capacity	4.5kA,6kA
Number of poles	1 P+N(1 module)
Rated current,In	6,10,13,16,20,25,32A
Rated voltage	240VAC
Rated Tripping Current	10,30,100,300mA
Residual current off time	≤0.1s
Characteristic	B,C Curve
Electrical endurance	4000
Mechanical endurance	10000
Ambient temperature (°C)	-25~+40Max.95% humidity
Connection terminal	Flexible conductor 16mm ² Rigid conductor 25mm ²
Type of terminal	Lug type and Pin type
Width	17.8mm



MGRN-32M



MGRN-32H

MGRN-32M



Type AC



Type A









Rated current(A)	I _{Δn}	Type AC 		Type A 		Packing unit
		B curve	C curve	B curve	C curve	
6	10mA	MGR-63M-B6/10	MGR-63M-C6/10	MGR-63M-B6/10-A	MGR-63M-C6/10-A	6
10		MGR-63M-B10/10	MGR-63M-C10/10	MGR-63M-B10/10-A	MGR-63M-C10/10-A	
13		MGR-63M-B13/10	MGR-63M-C13/10	MGR-63M-B13/10-A	MGR-63M-C13/10-A	
16		MGR-63M-B16/10	MGR-63M-C16/10	MGR-63M-B16/10-A	MGR-63M-C16/10-A	
20		MGR-63M-B20/10	MGR-63M-C20/10	MGR-63M-B20/10-A	MGR-63M-C20/10-A	
25		MGR-63M-B25/10	MGR-63M-C25/10	MGR-63M-B25/10-A	MGR-63M-C25/10-A	
32		MGR-63M-B32/10	MGR-63M-C32/10	MGR-63M-B32/10-A	MGR-63M-C32/10-A	

6	30mA	MGR-63M-B6/30	MGR-63M-C6/30	MGR-63M-B6/30-A	MGR-63M-C6/30-A	6
10		MGR-63M-B10/30	MGR-63M-C10/30	MGR-63M-B10/30-A	MGR-63M-C10/30-A	
13		MGR-63M-B13/30	MGR-63M-C13/30	MGR-63M-B13/30-A	MGR-63M-C13/30-A	
16		MGR-63M-B16/30	MGR-63M-C16/30	MGR-63M-B16/30-A	MGR-63M-C16/30-A	
20		MGR-63M-B20/30	MGR-63M-C20/30	MGR-63M-B20/30-A	MGR-63M-C20/30-A	
25		MGR-63M-B25/30	MGR-63M-C25/30	MGR-63M-B25/30-A	MGR-63M-C25/30-A	
32		MGR-63M-B32/30	MGR-63M-C32/30	MGR-63M-B32/30-A	MGR-63M-C32/30-A	

6	100mA	MGR-63M-B6/100	MGR-63M-C6/100	MGR-63M-B6/100-A	MGR-63M-C6/100-A	6
10		MGR-63M-B10/100	MGR-63M-C10/100	MGR-63M-B10/100-A	MGR-63M-C10/100-A	
13		MGR-63M-B13/100	MGR-63M-C13/100	MGR-63M-B13/100-A	MGR-63M-C13/100-A	
16		MGR-63M-B16/100	MGR-63M-C16/100	MGR-63M-B16/100-A	MGR-63M-C16/100-A	
20		MGR-63M-B20/100	MGR-63M-C20/100	MGR-63M-B20/100-A	MGR-63M-C20/100-A	
25		MGR-63M-B25/100	MGR-63M-C25/100	MGR-63M-B25/100-A	MGR-63M-C25/100-A	
32		MGR-63M-B32/100	MGR-63M-C32/100	MGR-63M-B32/100-A	MGR-63M-C32/100-A	

6	300mA	MGR-63M-B6/300	MGR-63M-C6/300	MGR-63M-B6/300-A	MGR-63M-C6/300-A	6
10		MGR-63M-B10/300	MGR-63M-C10/300	MGR-63M-B10/300-A	MGR-63M-C10/300-A	
13		MGR-63M-B13/300	MGR-63M-C13/300	MGR-63M-B13/300-A	MGR-63M-C13/300-A	
16		MGR-63M-B16/300	MGR-63M-C16/300	MGR-63M-B16/300-A	MGR-63M-C16/300-A	
20		MGR-63M-B20/300	MGR-63M-C20/300	MGR-63M-B20/300-A	MGR-63M-C20/300-A	
25		MGR-63M-B25/300	MGR-63M-C25/300	MGR-63M-B25/300-A	MGR-63M-C25/300-A	
32		MGR-63M-B32/300	MGR-63M-C32/300	MGR-63M-B32/300-A	MGR-63M-C32/300-A	

HGRN-32H	Rated current(A)	I _{Δn}	Type AC 		Type A 		Packing unit
			B curve	C curve	B curve	C curve	
	6	10mA	HGR-63H-B6/10	HGR-63H-C6/10	HGR-63H-B6/10-A	HGR-63H-C6/10-A	6
	10		HGR-63H-B10/10	HGR-63H-C10/10	HGR-63H-B10/10-A	HGR-63H-C10/10-A	
	13		HGR-63H-B13/10	HGR-63H-C13/10	HGR-63H-B13/10-A	HGR-63H-C13/10-A	
	16		HGR-63H-B16/10	HGR-63H-C16/10	HGR-63H-B16/10-A	HGR-63H-C16/10-A	
	20		HGR-63H-B20/10	HGR-63H-C20/10	HGR-63H-B20/10-A	HGR-63H-C20/10-A	
	25		HGR-63H-B25/10	HGR-63H-C25/10	HGR-63H-B25/10-A	HGR-63H-C25/10-A	
	32		HGR-63H-B32/10	HGR-63H-C32/10	HGR-63H-B32/10-A	HGR-63H-C32/10-A	
	6	30mA	HGR-63H-B6/30	HGR-63H-C6/30	HGR-63H-B6/30-A	HGR-63H-C6/30-A	6
	10		HGR-63H-B10/30	HGR-63H-C10/30	HGR-63H-B10/30-A	HGR-63H-C10/30-A	
	13		HGR-63H-B13/30	HGR-63H-C13/30	HGR-63H-B13/30-A	HGR-63H-C13/30-A	
	16		HGR-63H-B16/30	HGR-63H-C16/30	HGR-63H-B16/30-A	HGR-63H-C16/30-A	
	20		HGR-63H-B20/30	HGR-63H-C20/30	HGR-63H-B20/30-A	HGR-63H-C20/30-A	
	25		HGR-63H-B25/30	HGR-63H-C25/30	HGR-63H-B25/30-A	HGR-63H-C25/30-A	
	32		HGR-63H-B32/30	HGR-63H-C32/30	HGR-63H-B32/30-A	HGR-63H-C32/30-A	
	6	100mA	HGR-63H-B6/100	HGR-63H-C6/100	HGR-63H-B6/100-A	HGR-63H-C6/100-A	6
	10		HGR-63H-B10/100	HGR-63H-C10/100	HGR-63H-B10/100-A	HGR-63H-C10/100-A	
	13		HGR-63H-B13/100	HGR-63H-C13/100	HGR-63H-B13/100-A	HGR-63H-C13/100-A	
	16		HGR-63H-B16/100	HGR-63H-C16/100	HGR-63H-B16/100-A	HGR-63H-C16/100-A	
	20		HGR-63H-B20/100	HGR-63H-C20/100	HGR-63H-B20/100-A	HGR-63H-C20/100-A	
	25		HGR-63H-B25/100	HGR-63H-C25/100	HGR-63H-B25/100-A	HGR-63H-C25/100-A	
	32		HGR-63H-B32/100	HGR-63H-C32/100	HGR-63H-B32/100-A	HGR-63H-C32/100-A	
	6	300mA	HGR-63H-B6/300	HGR-63H-C6/300	HGR-63H-B6/300-A	HGR-63H-C6/300-A	6
	10		HGR-63H-B10/300	HGR-63H-C10/300	HGR-63H-B10/300-A	HGR-63H-C10/300-A	
	13		HGR-63H-B13/300	HGR-63H-C13/300	HGR-63H-B13/300-A	HGR-63H-C13/300-A	
	16		HGR-63H-B16/300	HGR-63H-C16/300	HGR-63H-B16/300-A	HGR-63H-C16/300-A	
	20		HGR-63H-B20/300	HGR-63H-C20/300	HGR-63H-B20/300-A	HGR-63H-C20/300-A	
	25		HGR-63H-B25/300	HGR-63H-C25/300	HGR-63H-B25/300-A	HGR-63H-C25/300-A	
	32		HGR-63H-B32/300	HGR-63H-C32/300	HGR-63H-B32/300-A	HGR-63H-C32/300-A	

Type AC



Type A



1. Curves

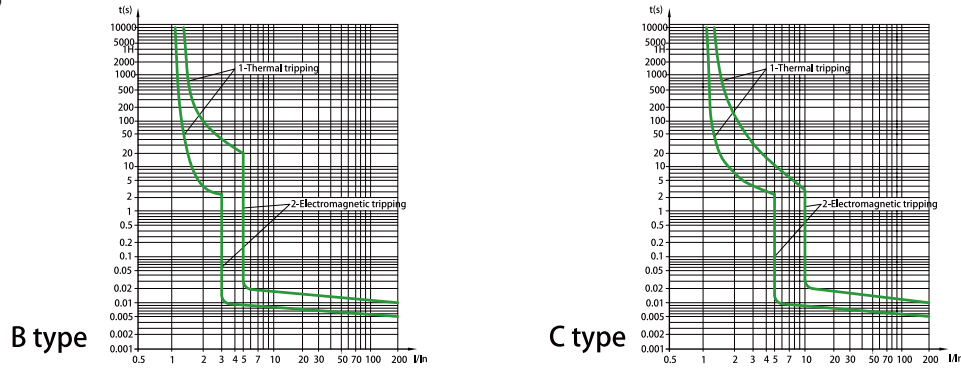

2. Breaking time of residual current

In(A)	IΔn(A)	Max. breaking time			
		IΔn	2IΔn	5IΔn	5A, 10A, 20A, 50A, 100A, 200A, 500A
6-32	0.01, 0.03, 0.1, 0.3	0.1s	0.08s	0.04s	0.04s

3. Wiring

The suitable conductors should be used for connection, see table below for relative parameters.

Rated current In (A)	Cross section area s (mm ²)	Tightening torque (N.m)
6	1	2
10	1.5	2
16-20	2.5	2
25	4	2
32	6	2

4. Tripping sensitivity data

- Switching and isolation function.
- Protection against overload and short-circuit currents.
- Protection against the effects of sinusoidal alternating earth fault currents.
- Protection against indirect contacts and additional protection against direct contacts.
- Protection against fire hazard caused by insulation faults.
- Used in residential building and distribution boards.

5. Overall and mounting dimensions

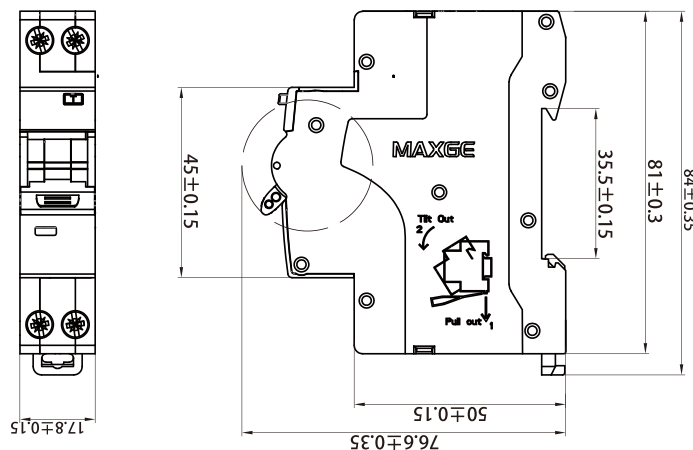

MGRN-32M/H

#AFDD

PREVENTS FIRES •

FITS IN NEW AND EXISTING INSTALLATIONS •

SWITCHED NEUTRAL •

4 IN 1 PROTECTION •

OVERLOAD

Test current: I_n :6-40A
1.13 x I_n No-trip
1.45 x I_n Trip

SHORT CIRCUIT

B, C characteristic
B:(3-5) x I_n
C:(5-10) x I_n

ARC FAULT

Serial Arcing Fault
Parallel Arcing Fault

EARTH LEAKAGE

$I_{\Delta n}$: 30, 100, 300mA
Type A & AC



EPBR-40AFD Series

Arc Fault Detection Device(AFDD)

Technical data

Standard	IEC/BS EN 62606, IEC/BS EN 61009-1
Rated conditional short-circuit current, I _{nc}	6kA
Protection	Overload, Short circuit, Ground fault, Arc fault
Rated current, I _n	6, 10, 16, 20, 25, 32A
Number of poles	1P+N(1 Module)
Rated sensitivity currents, I _{Δn}	30, 100, 300mA
Characteristic	B, C Curve
Rated residual non-operating current	0.5 X I _{Δn}
Rated impulse withstand voltage U _{imp}	4000V
Rated voltage 2pole	240VAC
Ambient temperature (°C)	-25~+40, Max. 95%humidity
Residual current off-time at I _{Δn}	≤0.1s
Type of trip	Electronic release
Type of terminal	Lug type and Pin type
Terminal capacity	Cables up to 25mm ²
Protection degree	IP20
Mechanical Endvrance	10000
Electricac Endvrance	1200
Installation	35mm DIN rail
Application	Consumer Unit



AFDD	Rated current(A)	$I_{\Delta n}$	Type AC 		Type A 		Packing unit
			B curve	C curve	B curve	C curve	
	6	30mA	AFDD-6K/B6/30	AFDD-6K/C6/30	AFDD-6K/B6/30-A	AFDD-6K/C6/30-A	5
	10		AFDD-6K/B10/30	AFDD-6K/C10/30	AFDD-6K/B10/30-A	AFDD-6K/C10/30-A	5
	16		AFDD-6K/B16/30	AFDD-6K/C16/30	AFDD-6K/B16/30-A	AFDD-6K/C16/30-A	5
	20		AFDD-6K/B20/30	AFDD-6K/C20/30	AFDD-6K/B20/30-A	AFDD-6K/C20/30-A	5
	25		AFDD-6K/B25/30	AFDD-6K/C25/30	AFDD-6K/B25/30-A	AFDD-6K/C25/30-A	5
	32		AFDD-6K/B32/30	AFDD-6K/C32/30	AFDD-6K/B32/30-A	AFDD-6K/C32/30-A	5
Type AC 	6	100mA	AFDD-6K/B6/100	AFDD-6K/C6/100	AFDD-6K/B6/100-A	AFDD-6K/C6/100-A	5
	10		AFDD-6K/B10/100	AFDD-6K/C10/100	AFDD-6K/B10/100-A	AFDD-6K/C10/100-A	5
	16		AFDD-6K/B16/100	AFDD-6K/C16/100	AFDD-6K/B16/100-A	AFDD-6K/C16/100-A	5
	20		AFDD-6K/B20/100	AFDD-6K/C20/100	AFDD-6K/B20/100-A	AFDD-6K/C20/100-A	5
	25		AFDD-6K/B25/100	AFDD-6K/C25/100	AFDD-6K/B25/100-A	AFDD-6K/C25/100-A	5
	32		AFDD-6K/B32/100	AFDD-6K/C32/100	AFDD-6K/B32/100-A	AFDD-6K/C32/100-A	5
	6	300mA	AFDD-6K/B6/300	AFDD-6K/C6/300	AFDD-6K/B6/300-A	AFDD-6K/C6/300-A	5
	10		AFDD-6K/B10/300	AFDD-6K/C10/300	AFDD-6K/B10/300-A	AFDD-6K/C10/300-A	5
	16		AFDD-6K/B16/300	AFDD-6K/C16/300	AFDD-6K/B16/300-A	AFDD-6K/C16/300-A	5
	20		AFDD-6K/B20/300	AFDD-6K/C20/300	AFDD-6K/B20/300-A	AFDD-6K/C20/300-A	5
	25		AFDD-6K/B25/300	AFDD-6K/C25/300	AFDD-6K/B25/300-A	AFDD-6K/C25/300-A	5
	32		AFDD-6K/B32/300	AFDD-6K/C32/300	AFDD-6K/B32/300-A	AFDD-6K/C32/300-A	5

1. AFDD FOR THE CONSUMER UNIT

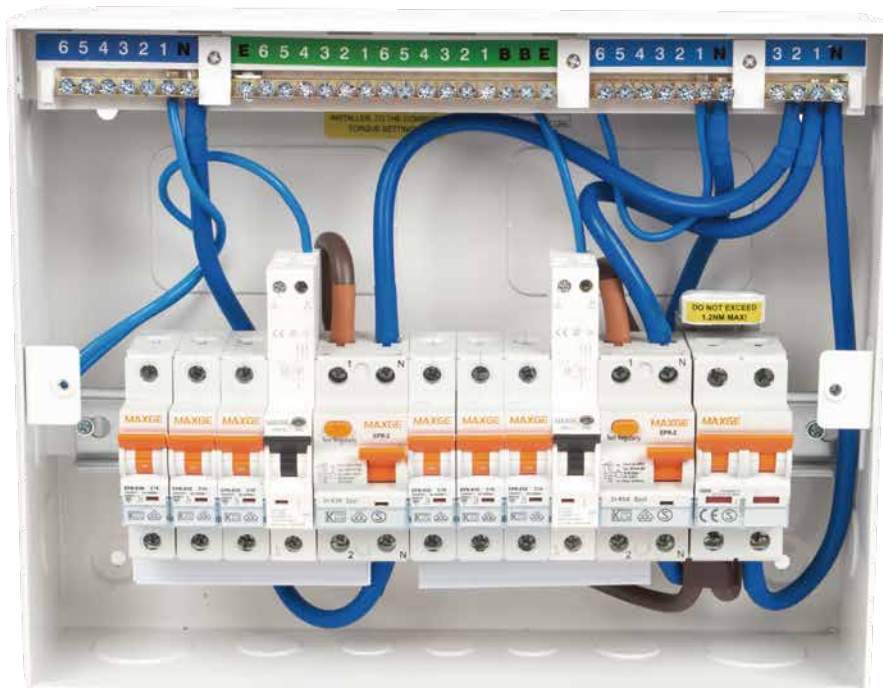

The 18th edition wiring regulations (BS7671) sets out requirements for electrical installations in the UK, including requirements for protection of persons, livestock & property against the risk from fires that may be generated & propagated in electrical installations.

Designers & installers are required to ensure that installations are arranged so that the risk of ignition from high temperatures or electric arc is minimised. Protection requirements include protecting against the risk of fire from insulation faults, arcs & sparks & high temperatures.

Installing arc fault detection devices is recommended in the 18th Edition as a method for mitigating the risk from fire in final AC circuits from arc faults.

2. Features & Benefits

Energy Limiting
Class 3



13 Plates Arc Chamber

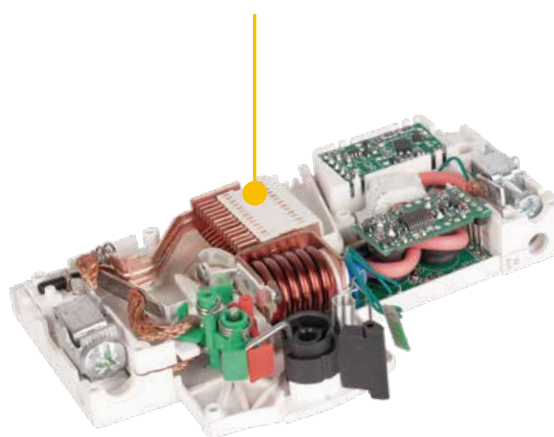

- ◆ Quick & Efficient Arc Quenching
- ◆ Very low let through energy, class 3
- ◆ Increases life of Installation & equipment

AFDD-40H Series

Arc Fault Detection Device(AFDD)

Standard	GB/T16917.1 IEC62606
Frame grade	40A
Number of poles	1P+N(With a protective pole, the N pole can be switched on and off)
Rated current, I_n	6,10,16,20,25,32,40A
Rated voltage U_e	AC 230/240V
Rated frequency	50Hz
Rated insulation voltage U_i	AC 400V
Rated impulse withstand voltage U_{imp}	4kV
Rated residual operating current I_{Δn}	10,30,100,300mA
Leakage type	AC type/ A type
Tripping type	General type (without delay function)
Relationship between operating function and power supply voltage	Related
When the power supply voltage fails	With overvoltage protection
1P+N	N pole with isolation function
Overcurrent protection type	Thermal magnetic protection
Overload long delay protection feature	1.13I _n : ≥1h no action; 1.45I _n : < 1h action
Short circuit instantaneous tripping characteristics	B: 3I _n ~5I _n ; C:5I _n ~10I _n
Operating short circuit breaking capacity I_{cs}	6kA
Rated short circuit breaking capacity I_{cn}=I_{cn1}	6kA
Rated residual energy receiving and breaking capacity I_{Δm}	2000A
Current limiting level	3
Mechanical life	10000 times
Electrical life	2000 times
Operating ambient temperature	-5°C~+40°C
Operating Relative humidity	Moisture and heat resistance type 2
Storage ambient temperature	-20°C~+60°C
Storage Relative humidity	≤80%
Protection grade	IP20
Installation	TH35mmx7.5 standard rail Compatible board thickness (0.95~1.1)mm<No attachments>
Wiring	Threaded version with external copper conductor; M5;2.5N.m<Terminal wiring capability 1~25mm ² (Cross-sectional area)>
Safety Instructions	Opening-closing indication or contact position indication other than handle
Security lock	Opening and closing lock interface

AFDD-40H





Type AC



Type A



Rated current(A)	I _{Δn}	Type AC 		Type A 		Packing unit
		B curve	C curve	B curve	C curve	
6	10mA	MGR-63H-B6/10	MGR-63H-C6/10	MGR-63H-B6/10-A	MGR-63H-C6/10-A	6
10		MGR-63H-B10/10	MGR-63H-C10/10	MGR-63H-B10/10-A	MGR-63H-C10/10-A	
13		MGR-63H-B13/10	MGR-63H-C13/10	MGR-63H-B13/10-A	MGR-63H-C13/10-A	
16		MGR-63H-B16/10	MGR-63H-C16/10	MGR-63H-B16/10-A	MGR-63H-C16/10-A	
20		MGR-63H-B20/10	MGR-63H-C20/10	MGR-63H-B20/10-A	MGR-63H-C20/10-A	
25		MGR-63H-B25/10	MGR-63H-C25/10	MGR-63H-B25/10-A	MGR-63H-C25/10-A	
32		MGR-63H-B32/10	MGR-63H-C32/10	MGR-63H-B32/10-A	MGR-63H-C32/10-A	
40		MGR-63H-B40/10	MGR-63H-C40/10	MGR-63H-B40/10-A	MGR-63H-C40/10-A	

6	30mA	MGR-63H-B6/30	MGR-63H-C6/30	MGR-63H-B6/30-A	MGR-63H-C6/30-A	6
10		MGR-63H-B10/30	MGR-63H-C10/30	MGR-63H-B10/30-A	MGR-63H-C10/30-A	
13		MGR-63H-B13/30	MGR-63H-C13/30	MGR-63H-B13/30-A	MGR-63H-C13/30-A	
16		MGR-63H-B16/30	MGR-63H-C16/30	MGR-63H-B16/30-A	MGR-63H-C16/30-A	
20		MGR-63H-B20/30	MGR-63H-C20/30	MGR-63H-B20/30-A	MGR-63H-C20/30-A	
25		MGR-63H-B25/30	MGR-63H-C25/30	MGR-63H-B25/30-A	MGR-63H-C25/30-A	
32		MGR-63H-B32/30	MGR-63H-C32/30	MGR-63H-B32/30-A	MGR-63H-C32/30-A	
40		MGR-63H-B40/30	MGR-63H-C40/30	MGR-63H-B40/30-A	MGR-63H-C40/30-A	

6	100mA	MGR-63H-B6/100	MGR-63H-C6/100	MGR-63H-B6/100-A	MGR-63H-C6/100-A	6
10		MGR-63H-B10/100	MGR-63H-C10/100	MGR-63H-B10/100-A	MGR-63H-C10/100-A	
13		MGR-63H-B13/100	MGR-63H-C13/100	MGR-63H-B13/100-A	MGR-63H-C13/100-A	
16		MGR-63H-B16/100	MGR-63H-C16/100	MGR-63H-B16/100-A	MGR-63H-C16/100-A	
20		MGR-63H-B20/100	MGR-63H-C20/100	MGR-63H-B20/100-A	MGR-63H-C20/100-A	
25		MGR-63H-B25/100	MGR-63H-C25/100	MGR-63H-B25/100-A	MGR-63H-C25/100-A	
32		MGR-63H-B32/100	MGR-63H-C32/100	MGR-63H-B32/100-A	MGR-63H-C32/100-A	
40		MGR-63H-B40/100	MGR-63H-C40/100	MGR-63H-B40/100-A	MGR-63H-C40/100-A	

6	300mA	MGR-63H-B6/300	MGR-63H-C6/300	MGR-63H-B6/300-A	MGR-63H-C6/300-A	6
10		MGR-63H-B10/300	MGR-63H-C10/300	MGR-63H-B10/300-A	MGR-63H-C10/300-A	
13		MGR-63H-B13/300	MGR-63H-C13/300	MGR-63H-B13/300-A	MGR-63H-C13/300-A	
16		MGR-63H-B16/300	MGR-63H-C16/300	MGR-63H-B16/300-A	MGR-63H-C16/300-A	
20		MGR-63H-B20/300	MGR-63H-C20/300	MGR-63H-B20/300-A	MGR-63H-C20/300-A	
25		MGR-63H-B25/300	MGR-63H-C25/300	MGR-63H-B25/300-A	MGR-63H-C25/300-A	
32		MGR-63H-B32/300	MGR-63H-C32/300	MGR-63H-B32/300-A	MGR-63H-C32/300-A	
40		MGR-63H-B40/300	MGR-63H-C40/300	MGR-63H-B40/300-A	MGR-63H-C40/300-A	

Overload Operation

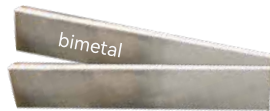
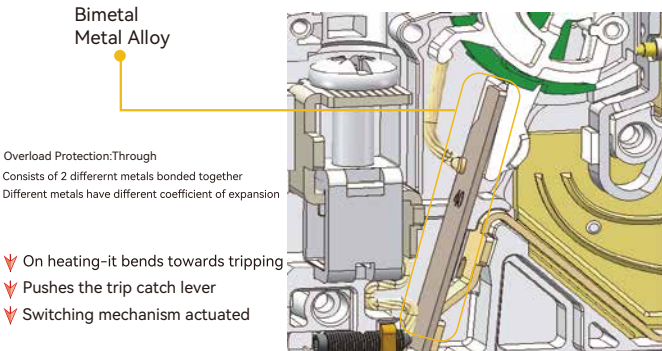

Short Circuit Operation

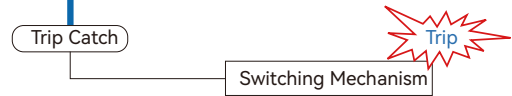
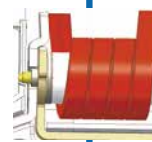
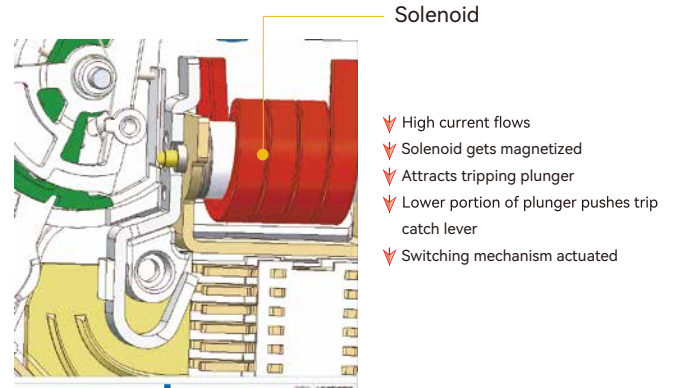

Features & Benefits

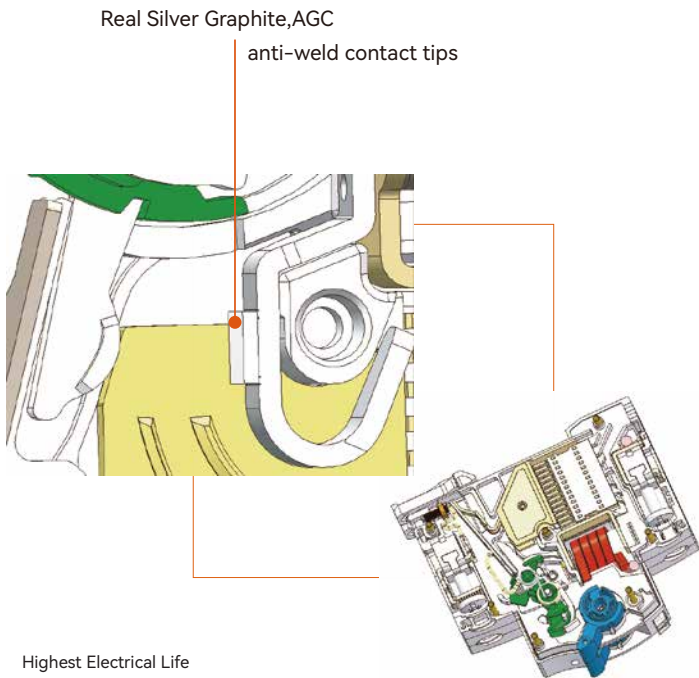

Highest Electrical Life
Maximum Safety against Contact welding
Rare possibility of AFDD replacement



- Quick & Efficient Arc Quenching
- Very low let through energy, class 3
- Increases life of Installation & equipment

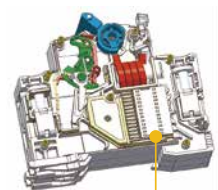

13 Plates Arc Chamber

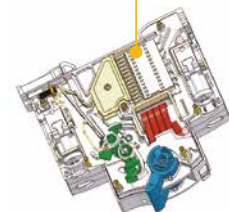

SGRM-63LE Series

(Electronic/Electro-magnetic)

Residual Current Operated Circuit Breaker(RCBO)

Technical data

Standard	EN/IEC61009-1
Breaking capacity	6kA
Protection	Ground fault, overcurrent and short circuit
Rated current, I_n	6,10,16,20,25,32,40, 50, 63A
Operating, I_{Δn}	10,30,100,300mA
Characteristic	B,C,D Curve
Rated residual current operated making & breaking capacity I_{Δm}	2000A
Rated residual non-operated current I_{Δn}	0.5I _{Δn}
Rated impulse withstand voltage U_{imp}	4kV
Number of poles	1P+N(N pole can not on/off) ,2P, 3P,3P+N(N pole can not on/off) ,4P
Rated voltages	1P+N, 2P 230VAC 3P, 3P+N, 4P 400VAC
Ambient temperature (°C)	-5~+40,Max. 80%humidity
Residual current off-time	≤0.1 sec
Type of trip	Ground fault Electronic/Electro-magnetic Over current Thermal-magnetic
Protection degree	IP20
Terminal capacity	16mm ² flexible/25mm ² rigid
Installation	35mm DIN rail
Type of terminal	Lug type and Pin type



SGRM-63LE-1P+N

SGRM-63LE-2P

SGRM-63LE-3P

SGRM-63LE-3P+N

SGRM-63LE-4P

SGRM-63LE-RCBO	Rated current(A)	$I_{\Delta n}$	Type AC 			Packing unit
			B curve	C curve	D curve	
	6	10mA	SGRM-63LE-1-B6N/10	SGRM-63LE-1-C6N/10	SGRM-63LE-1-D6N/10	1
	10		SGRM-63LE-1-B10N/10	SGRM-63LE-1-C10N/10	SGRM-63LE-1-D10N/10	1
	16		SGRM-63LE-1-B16N/10	SGRM-63LE-1-C16N/10	SGRM-63LE-1-D16N/10	1
	20		SGRM-63LE-1-B20N/10	SGRM-63LE-1-C20N/10	SGRM-63LE-1-D20N/10	1
	25		SGRM-63LE-1-B25N/10	SGRM-63LE-1-C25N/10	SGRM-63LE-1-D25N/10	1
	32		SGRM-63LE-1-B32N/10	SGRM-63LE-1-C32N/10	SGRM-63LE-1-D32N/10	1
	40		SGRM-63LE-1-B40N/10	SGRM-63LE-1-C40N/10	SGRM-63LE-1-D40N/10	1
	50		SGRM-63LE-1-B50N/10	SGRM-63LE-1-C50N/10	SGRM-63LE-1-D50N/10	1
	63		SGRM-63LE-1-B63N/10	SGRM-63LE-1-C63N/10	SGRM-63LE-1-D63N/10	1
	6	30mA	SGRM-63LE-1-B6N/30	SGRM-63LE-1-C6N/30	SGRM-63LE-1-D6N/30	1
	10		SGRM-63LE-1-B10N/30	SGRM-63LE-1-C10N/30	SGRM-63LE-1-D10N/30	1
	16		SGRM-63LE-1-B16N/30	SGRM-63LE-1-C16N/30	SGRM-63LE-1-D16N/30	1
	20		SGRM-63LE-1-B20N/30	SGRM-63LE-1-C20N/30	SGRM-63LE-1-D20N/30	1
	25		SGRM-63LE-1-B25N/30	SGRM-63LE-1-C25N/30	SGRM-63LE-1-D25N/30	1
	32		SGRM-63LE-1-B32N/30	SGRM-63LE-1-C32N/30	SGRM-63LE-1-D32N/30	1
	40		SGRM-63LE-1-B40N/30	SGRM-63LE-1-C40N/30	SGRM-63LE-1-D40N/30	1
	50		SGRM-63LE-1-B50N/30	SGRM-63LE-1-C50N/30	SGRM-63LE-1-D50N/30	1
	63		SGRM-63LE-1-B63N/30	SGRM-63LE-1-C63N/30	SGRM-63LE-1-D63N/30	1
	6	100mA	SGRM-63LE-1-B6N/100	SGRM-63LE-1-C6N/100	SGRM-63LE-1-D6N/100	1
	10		SGRM-63LE-1-B10N/100	SGRM-63LE-1-C10N/100	SGRM-63LE-1-D10N/100	1
	16		SGRM-63LE-1-B16N/100	SGRM-63LE-1-C16N/100	SGRM-63LE-1-D16N/100	1
	20		SGRM-63LE-1-B20N/100	SGRM-63LE-1-C20N/100	SGRM-63LE-1-D20N/100	1
	25		SGRM-63LE-1-B25N/100	SGRM-63LE-1-C25N/100	SGRM-63LE-1-D25N/100	1
	32		SGRM-63LE-1-B32N/100	SGRM-63LE-1-C32N/100	SGRM-63LE-1-D32N/100	1
	40		SGRM-63LE-1-B40N/100	SGRM-63LE-1-C40N/100	SGRM-63LE-1-D40N/100	1
	50		SGRM-63LE-1-B50N/100	SGRM-63LE-1-C50N/100	SGRM-63LE-1-D50N/100	1
	63		SGRM-63LE-1-B63N/100	SGRM-63LE-1-C63N/100	SGRM-63LE-1-D63N/100	1
	6	300mA	SGRM-63LE-1-B6N/300	SGRM-63LE-1-C6N/300	SGRM-63LE-1-D6N/300	1
	10		SGRM-63LE-1-B10N/300	SGRM-63LE-1-C10N/300	SGRM-63LE-1-D10N/300	1
	16		SGRM-63LE-1-B16N/300	SGRM-63LE-1-C16N/300	SGRM-63LE-1-D16N/300	1
	20		SGRM-63LE-1-B20N/300	SGRM-63LE-1-C20N/300	SGRM-63LE-1-D20N/300	1
	25		SGRM-63LE-1-B25N/300	SGRM-63LE-1-C25N/300	SGRM-63LE-1-D25N/300	1
	32		SGRM-63LE-1-B32N/300	SGRM-63LE-1-C32N/300	SGRM-63LE-1-D32N/300	1
	40		SGRM-63LE-1-B40N/300	SGRM-63LE-1-C40N/300	SGRM-63LE-1-D40N/300	1
	50		SGRM-63LE-1-B50N/300	SGRM-63LE-1-C50N/300	SGRM-63LE-1-D50N/300	1
	63		SGRM-63LE-1-B63N/300	SGRM-63LE-1-C63N/300	SGRM-63LE-1-D63N/300	1



SGRM-63LE-1P+N

SGRM-63LE-RCBO	Rated current(A)	$I_{\Delta n}$	Type AC 			Packing unit
			B curve	C curve	D curve	
	6	10mA	SGRM-63LE-2-B6/10	SGRM-63LE-2-C6/10	SGRM-63LE-2-D6/10	1
	10		SGRM-63LE-2-B10/10	SGRM-63LE-2-C10/10	SGRM-63LE-2-D10/10	1
	16		SGRM-63LE-2-B16/10	SGRM-63LE-2-C16/10	SGRM-63LE-2-D16/10	1
	20		SGRM-63LE-2-B20/10	SGRM-63LE-2-C20/10	SGRM-63LE-2-D20/10	1
	25		SGRM-63LE-2-B25/10	SGRM-63LE-2-C25/10	SGRM-63LE-2-D25/10	1
	32		SGRM-63LE-2-B32/10	SGRM-63LE-2-C32/10	SGRM-63LE-2-D32/10	1
	40		SGRM-63LE-2-B40/10	SGRM-63LE-2-C40/10	SGRM-63LE-2-D40/10	1
	50		SGRM-63LE-2-B50/10	SGRM-63LE-2-C50/10	SGRM-63LE-2-D50/10	1
	63		SGRM-63LE-2-B63/10	SGRM-63LE-2-C63/10	SGRM-63LE-2-D63/10	1
	6	30mA	SGRM-63LE-2-B6/30	SGRM-63LE-2-C6/30	SGRM-63LE-2-D6/30	1
	10		SGRM-63LE-2-B10/30	SGRM-63LE-2-C10/30	SGRM-63LE-2-D10/30	1
	16		SGRM-63LE-2-B16/30	SGRM-63LE-2-C16/30	SGRM-63LE-2-D16/30	1
	20		SGRM-63LE-2-B20/30	SGRM-63LE-2-C20/30	SGRM-63LE-2-D20/30	1
	25		SGRM-63LE-2-B25/30	SGRM-63LE-2-C25/30	SGRM-63LE-2-D25/30	1
	32		SGRM-63LE-2-B32/30	SGRM-63LE-2-C32/30	SGRM-63LE-2-D32/30	1
	40		SGRM-63LE-2-B40/30	SGRM-63LE-2-C40/30	SGRM-63LE-2-D40/30	1
	50		SGRM-63LE-2-B50/30	SGRM-63LE-2-C50/30	SGRM-63LE-2-D50/30	1
	63		SGRM-63LE-2-B63/30	SGRM-63LE-2-C63/30	SGRM-63LE-2-D63/30	1
	6	100mA	SGRM-63LE-2-B6/100	SGRM-63LE-2-C6/100	SGRM-63LE-2-D6/100	1
	10		SGRM-63LE-2-B10/100	SGRM-63LE-2-C10/100	SGRM-63LE-2-D10/100	1
	16		SGRM-63LE-2-B16/100	SGRM-63LE-2-C16/100	SGRM-63LE-2-D16/100	1
	20		SGRM-63LE-2-B20/100	SGRM-63LE-2-C20/100	SGRM-63LE-2-D20/100	1
	25		SGRM-63LE-2-B25/100	SGRM-63LE-2-C25/100	SGRM-63LE-2-D25/100	1
	32		SGRM-63LE-2-B32/100	SGRM-63LE-2-C32/100	SGRM-63LE-2-D32/100	1
	40		SGRM-63LE-2-B40/100	SGRM-63LE-2-C40/100	SGRM-63LE-2-D40/100	1
	50		SGRM-63LE-2-B50/100	SGRM-63LE-2-C50/100	SGRM-63LE-2-D50/100	1
	63		SGRM-63LE-2-B63/100	SGRM-63LE-2-C63/100	SGRM-63LE-2-D63/100	1
	6	300mA	SGRM-63LE-2-B6/300	SGRM-63LE-2-C6/300	SGRM-63LE-2-D6/300	1
	10		SGRM-63LE-2-B10/300	SGRM-63LE-2-C10/300	SGRM-63LE-2-D10/300	1
	16		SGRM-63LE-2-B16/300	SGRM-63LE-2-C16/300	SGRM-63LE-2-D16/300	1
	20		SGRM-63LE-2-B20/300	SGRM-63LE-2-C20/300	SGRM-63LE-2-D20/300	1
	25		SGRM-63LE-2-B25/300	SGRM-63LE-2-C25/300	SGRM-63LE-2-D25/300	1
	32		SGRM-63LE-2-B32/300	SGRM-63LE-2-C32/300	SGRM-63LE-2-D32/300	1
	40		SGRM-63LE-2-B40/300	SGRM-63LE-2-C40/300	SGRM-63LE-2-D40/300	1
	50		SGRM-63LE-2-B50/300	SGRM-63LE-2-C50/300	SGRM-63LE-2-D50/300	1
	63		SGRM-63LE-2-B63/300	SGRM-63LE-2-C63/300	SGRM-63LE-2-D63/300	1



SGRM-63LE-2P

SGRM-63LE-RCBO	Rated current(A)	$I_{\Delta n}$	Type AC 			Packing unit
			B curve	C curve	D curve	
	6	10mA	SGRM-63LE-3-B6/10	SGRM-63LE-3-C6/10	SGRM-63LE-3-D6/10	1
	10		SGRM-63LE-3-B10/10	SGRM-63LE-3-C10/10	SGRM-63LE-3-D10/10	1
	16		SGRM-63LE-3-B16/10	SGRM-63LE-3-C16/10	SGRM-63LE-3-D16/10	1
	20		SGRM-63LE-3-B20/10	SGRM-63LE-3-C20/10	SGRM-63LE-3-D20/10	1
	25		SGRM-63LE-3-B25/10	SGRM-63LE-3-C25/10	SGRM-63LE-3-D25/10	1
	32		SGRM-63LE-3-B32/10	SGRM-63LE-3-C32/10	SGRM-63LE-3-D32/10	1
	40		SGRM-63LE-3-B40/10	SGRM-63LE-3-C40/10	SGRM-63LE-3-D40/10	1
	50		SGRM-63LE-3-B50/10	SGRM-63LE-3-C50/10	SGRM-63LE-3-D50/10	1
	63		SGRM-63LE-3-B63/10	SGRM-63LE-3-C63/10	SGRM-63LE-3-D63/10	1
	6	30mA	SGRM-63LE-3-B6/30	SGRM-63LE-3-C6/30	SGRM-63LE-3-D6/30	1
	10		SGRM-63LE-3-B10/30	SGRM-63LE-3-C10/30	SGRM-63LE-3-D10/30	1
	16		SGRM-63LE-3-B16/30	SGRM-63LE-3-C16/30	SGRM-63LE-3-D16/30	1
	20		SGRM-63LE-3-B20/30	SGRM-63LE-3-C20/30	SGRM-63LE-3-D20/30	1
	25		SGRM-63LE-3-B25/30	SGRM-63LE-3-C25/30	SGRM-63LE-3-D25/30	1
	32		SGRM-63LE-3-B32/30	SGRM-63LE-3-C32/30	SGRM-63LE-3-D32/30	1
	40		SGRM-63LE-3-B40/30	SGRM-63LE-3-C40/30	SGRM-63LE-3-D40/30	1
	50		SGRM-63LE-3-B50/30	SGRM-63LE-3-C50/30	SGRM-63LE-3-D50/30	1
	63		SGRM-63LE-3-B63/30	SGRM-63LE-3-C63/30	SGRM-63LE-3-D63/30	1
	6	100mA	SGRM-63LE-3-B6/100	SGRM-63LE-3-C6/100	SGRM-63LE-3-D6/100	1
	10		SGRM-63LE-3-B10/100	SGRM-63LE-3-C10/100	SGRM-63LE-3-D10/100	1
	16		SGRM-63LE-3-B16/100	SGRM-63LE-3-C16/100	SGRM-63LE-3-D16/100	1
	20		SGRM-63LE-3-B20/100	SGRM-63LE-3-C20/100	SGRM-63LE-3-D20/100	1
	25		SGRM-63LE-3-B25/100	SGRM-63LE-3-C25/100	SGRM-63LE-3-D25/100	1
	32		SGRM-63LE-3-B32/100	SGRM-63LE-3-C32/100	SGRM-63LE-3-D32/100	1
	40		SGRM-63LE-3-B40/100	SGRM-63LE-3-C40/100	SGRM-63LE-3-D40/100	1
	50		SGRM-63LE-3-B50/100	SGRM-63LE-3-C50/100	SGRM-63LE-3-D50/100	1
	63		SGRM-63LE-3-B63/100	SGRM-63LE-3-C63/100	SGRM-63LE-3-D63/100	1
	6	300mA	SGRM-63LE-3-B6/300	SGRM-63LE-3-C6/300	SGRM-63LE-3-D6/300	1
	10		SGRM-63LE-3-B10/300	SGRM-63LE-3-C10/300	SGRM-63LE-3-D10/300	1
	16		SGRM-63LE-3-B16/300	SGRM-63LE-3-C16/300	SGRM-63LE-3-D16/300	1
	20		SGRM-63LE-3-B20/300	SGRM-63LE-3-C20/300	SGRM-63LE-3-D20/300	1
	25		SGRM-63LE-3-B25/300	SGRM-63LE-3-C25/300	SGRM-63LE-3-D25/300	1
	32		SGRM-63LE-3-B32/300	SGRM-63LE-3-C32/300	SGRM-63LE-3-D32/300	1
	40		SGRM-63LE-3-B40/300	SGRM-63LE-3-C40/300	SGRM-63LE-3-D40/300	1
	50		SGRM-63LE-3-B50/300	SGRM-63LE-3-C50/300	SGRM-63LE-3-D50/300	1
	63		SGRM-63LE-3-B63/300	SGRM-63LE-3-C63/300	SGRM-63LE-3-D63/300	1



SGRM-63LE-3P

SGRM-63LE-RCBO	Rated current(A)	$I_{\Delta n}$	Type AC 			Packing unit
			B curve	C curve	D curve	
	6	10mA	SGRM-63LE-3-B6N/10	SGRM-63LE-3-C6N/10	SGRM-63LE-3-D6N/10	1
	10		SGRM-63LE-3-B10N/10	SGRM-63LE-3-C10N/10	SGRM-63LE-3-D10N/10	1
	16		SGRM-63LE-3-B16N/10	SGRM-63LE-3-C16N/10	SGRM-63LE-3-D16N/10	1
	20		SGRM-63LE-3-B20N/10	SGRM-63LE-3-C20N/10	SGRM-63LE-3-D20N/10	1
	25		SGRM-63LE-3-B25N/10	SGRM-63LE-3-C25N/10	SGRM-63LE-3-D25N/10	1
	32		SGRM-63LE-3-B32N/10	SGRM-63LE-3-C32N/10	SGRM-63LE-3-D32N/10	1
	40		SGRM-63LE-3-B40N/10	SGRM-63LE-3-C40N/10	SGRM-63LE-3-D40N/10	1
	50		SGRM-63LE-3-B50N/10	SGRM-63LE-3-C50N/10	SGRM-63LE-3-D50N/10	1
	63		SGRM-63LE-3-B63N/10	SGRM-63LE-3-C63N/10	SGRM-63LE-3-D63N/10	1
	6	30mA	SGRM-63LE-3-B6N/30	SGRM-63LE-3-C6N/30	SGRM-63LE-3-D6N/30	1
	10		SGRM-63LE-3-B10N/30	SGRM-63LE-3-C10N/30	SGRM-63LE-3-D10N/30	1
	16		SGRM-63LE-3-B16N/30	SGRM-63LE-3-C16N/30	SGRM-63LE-3-D16N/30	1
	20		SGRM-63LE-3-B20N/30	SGRM-63LE-3-C20N/30	SGRM-63LE-3-D20N/30	1
	25		SGRM-63LE-3-B25N/30	SGRM-63LE-3-C25N/30	SGRM-63LE-3-D25N/30	1
	32		SGRM-63LE-3-B32N/30	SGRM-63LE-3-C32N/30	SGRM-63LE-3-D32N/30	1
	40		SGRM-63LE-3-B40N/30	SGRM-63LE-3-C40N/30	SGRM-63LE-3-D40N/30	1
	50		SGRM-63LE-3-B50N/30	SGRM-63LE-3-C50N/30	SGRM-63LE-3-D50N/30	1
	63		SGRM-63LE-3-B63N/30	SGRM-63LE-3-C63N/30	SGRM-63LE-3-D63N/30	1
	6	100mA	SGRM-63LE-3-B6N/100	SGRM-63LE-3-C6N/100	SGRM-63LE-3-D6N/100	1
	10		SGRM-63LE-3-B10N/100	SGRM-63LE-3-C10N/100	SGRM-63LE-3-D10N/100	1
	16		SGRM-63LE-3-B16N/100	SGRM-63LE-3-C16N/100	SGRM-63LE-3-D16N/100	1
	20		SGRM-63LE-3-B20N/100	SGRM-63LE-3-C20N/100	SGRM-63LE-3-D20N/100	1
	25		SGRM-63LE-3-B25N/100	SGRM-63LE-3-C25N/100	SGRM-63LE-3-D25N/100	1
	32		SGRM-63LE-3-B32N/100	SGRM-63LE-3-C32N/100	SGRM-63LE-3-D32N/100	1
	40		SGRM-63LE-3-B40N/100	SGRM-63LE-3-C40N/100	SGRM-63LE-3-D40N/100	1
	50		SGRM-63LE-3-B50N/100	SGRM-63LE-3-C50N/100	SGRM-63LE-3-D50N/100	1
	63		SGRM-63LE-3-B63N/100	SGRM-63LE-3-C63N/100	SGRM-63LE-3-D63N/100	1
	6	300mA	SGRM-63LE-3-B6N/300	SGRM-63LE-3-C6N/300	SGRM-63LE-3-D6N/300	1
	10		SGRM-63LE-3-B10N/300	SGRM-63LE-3-C10N/300	SGRM-63LE-3-D10N/300	1
	16		SGRM-63LE-3-B16N/300	SGRM-63LE-3-C16N/300	SGRM-63LE-3-D16N/300	1
	20		SGRM-63LE-3-B20N/300	SGRM-63LE-3-C20N/300	SGRM-63LE-3-D20N/300	1
	25		SGRM-63LE-3-B25N/300	SGRM-63LE-3-C25N/300	SGRM-63LE-3-D25N/300	1
	32		SGRM-63LE-3-B32N/300	SGRM-63LE-3-C32N/300	SGRM-63LE-3-D32N/300	1
	40		SGRM-63LE-3-B40N/300	SGRM-63LE-3-C40N/300	SGRM-63LE-3-D40N/300	1
	50		SGRM-63LE-3-B50N/300	SGRM-63LE-3-C50N/300	SGRM-63LE-3-D50N/300	1
	63		SGRM-63LE-3-B63N/300	SGRM-63LE-3-C63N/300	SGRM-63LE-3-D63N/300	1



SGRM-63LE-3P+N

SGRM-63LE-RCBO	Rated current(A)	$I_{\Delta n}$	Type AC 			Packing unit
			B curve	C curve	D curve	
	6	10mA	SGRM-63LE-4-B6/10	SGRM-63LE-4-C6/10	SGRM-63LE-4-D6/10	1
	10		SGRM-63LE-4-B10/10	SGRM-63LE-4-C10/10	SGRM-63LE-4-D10/10	1
	16		SGRM-63LE-4-B16/10	SGRM-63LE-4-C16/10	SGRM-63LE-4-D16/10	1
	20		SGRM-63LE-4-B20/10	SGRM-63LE-4-C20/10	SGRM-63LE-4-D20/10	1
	25		SGRM-63LE-4-B25/10	SGRM-63LE-4-C25/10	SGRM-63LE-4-D25/10	1
	32		SGRM-63LE-4-B32/10	SGRM-63LE-4-C32/10	SGRM-63LE-4-D32/10	1
	40		SGRM-63LE-4-B40/10	SGRM-63LE-4-C40/10	SGRM-63LE-4-D40/10	1
	50		SGRM-63LE-4-B50/10	SGRM-63LE-4-C50/10	SGRM-63LE-4-D50/10	1
	63		SGRM-63LE-4-B63/10	SGRM-63LE-4-C63/10	SGRM-63LE-4-D63/10	1
	6		30mA	SGRM-63LE-4-B6/30	SGRM-63LE-4-C6/30	SGRM-63LE-4-D6/30
	10	SGRM-63LE-4-B10/30		SGRM-63LE-4-C10/30	SGRM-63LE-4-D10/30	1
	16	SGRM-63LE-4-B16/30		SGRM-63LE-4-C16/30	SGRM-63LE-4-D16/30	1
	20	SGRM-63LE-4-B20/30		SGRM-63LE-4-C20/30	SGRM-63LE-4-D20/30	1
	25	SGRM-63LE-4-B25/30		SGRM-63LE-4-C25/30	SGRM-63LE-4-D25/30	1
	32	SGRM-63LE-4-B32/30		SGRM-63LE-4-C32/30	SGRM-63LE-4-D32/30	1
	40	SGRM-63LE-4-B40/30		SGRM-63LE-4-C40/30	SGRM-63LE-4-D40/30	1
	50	SGRM-63LE-4-B50/30		SGRM-63LE-4-C50/30	SGRM-63LE-4-D50/30	1
	63	SGRM-63LE-4-B63/30		SGRM-63LE-4-C63/30	SGRM-63LE-4-D63/30	1
	6	100mA		SGRM-63LE-4-B6/100	SGRM-63LE-4-C6/100	SGRM-63LE-4-D6/100
	10		SGRM-63LE-4-B10/100	SGRM-63LE-4-C10/100	SGRM-63LE-4-D10/100	1
	16		SGRM-63LE-4-B16/100	SGRM-63LE-4-C16/100	SGRM-63LE-4-D16/100	1
	20		SGRM-63LE-4-B20/100	SGRM-63LE-4-C20/100	SGRM-63LE-4-D20/100	1
	25		SGRM-63LE-4-B25/100	SGRM-63LE-4-C25/100	SGRM-63LE-4-D25/100	1
	32		SGRM-63LE-4-B32/100	SGRM-63LE-4-C32/100	SGRM-63LE-4-D32/100	1
	40		SGRM-63LE-4-B40/100	SGRM-63LE-4-C40/100	SGRM-63LE-4-D40/100	1
	50		SGRM-63LE-4-B50/100	SGRM-63LE-4-C50/100	SGRM-63LE-4-D50/100	1
	63		SGRM-63LE-4-B63/100	SGRM-63LE-4-C63/100	SGRM-63LE-4-D63/100	1
	6		300mA	SGRM-63LE-4-B6/300	SGRM-63LE-4-C6/300	SGRM-63LE-4-D6/300
	10	SGRM-63LE-4-B10/300		SGRM-63LE-4-C10/300	SGRM-63LE-4-D10/300	1
	16	SGRM-63LE-4-B16/300		SGRM-63LE-4-C16/300	SGRM-63LE-4-D16/300	1
	20	SGRM-63LE-4-B20/300		SGRM-63LE-4-C20/300	SGRM-63LE-4-D20/300	1
	25	SGRM-63LE-4-B25/300		SGRM-63LE-4-C25/300	SGRM-63LE-4-D25/300	1
	32	SGRM-63LE-4-B32/300		SGRM-63LE-4-C32/300	SGRM-63LE-4-D32/300	1
	40	SGRM-63LE-4-B40/300		SGRM-63LE-4-C40/300	SGRM-63LE-4-D40/300	1
	50	SGRM-63LE-4-B50/300		SGRM-63LE-4-C50/300	SGRM-63LE-4-D50/300	1
	63	SGRM-63LE-4-B63/300		SGRM-63LE-4-C63/300	SGRM-63LE-4-D63/300	1





SGRM-63LE-4P

SGRM-63LE-RCBO	Rated current(A)	$I_{\Delta n}$	Type A 			Packing unit
			B curve	C curve	D curve	
	6	10mA	SGRM-63LE-1-B6N/10-A	SGRM-63LE-1-C6N/10-A	SGRM-63LE-1-D6N/10-A	1
	10		SGRM-63LE-1-B10N/10-A	SGRM-63LE-1-C10N/10-A	SGRM-63LE-1-D10N/10-A	1
	16		SGRM-63LE-1-B16N/10-A	SGRM-63LE-1-C16N/10-A	SGRM-63LE-1-D16N/10-A	1
	20		SGRM-63LE-1-B20N/10-A	SGRM-63LE-1-C20N/10-A	SGRM-63LE-1-D20N/10-A	1
	25		SGRM-63LE-1-B25N/10-A	SGRM-63LE-1-C25N/10-A	SGRM-63LE-1-D25N/10-A	1
	32		SGRM-63LE-1-B32N/10-A	SGRM-63LE-1-C32N/10-A	SGRM-63LE-1-D32N/10-A	1
	40		SGRM-63LE-1-B40N/10-A	SGRM-63LE-1-C40N/10-A	SGRM-63LE-1-D40N/10-A	1
	50		SGRM-63LE-1-B50N/10-A	SGRM-63LE-1-C50N/10-A	SGRM-63LE-1-D50N/10-A	1
	63		SGRM-63LE-1-B63N/10-A	SGRM-63LE-1-C63N/10-A	SGRM-63LE-1-D63N/10-A	1
	6	30mA	SGRM-63LE-1-B6N/30-A	SGRM-63LE-1-C6N/30-A	SGRM-63LE-1-D6N/30-A	1
	10		SGRM-63LE-1-B10N/30-A	SGRM-63LE-1-C10N/30-A	SGRM-63LE-1-D10N/30-A	1
	16		SGRM-63LE-1-B16N/30-A	SGRM-63LE-1-C16N/30-A	SGRM-63LE-1-D16N/30-A	1
	20		SGRM-63LE-1-B20N/30-A	SGRM-63LE-1-C20N/30-A	SGRM-63LE-1-D20N/30-A	1
	25		SGRM-63LE-1-B25N/30-A	SGRM-63LE-1-C25N/30-A	SGRM-63LE-1-D25N/30-A	1
	32		SGRM-63LE-1-B32N/30-A	SGRM-63LE-1-C32N/30-A	SGRM-63LE-1-D32N/30-A	1
	40		SGRM-63LE-1-B40N/30-A	SGRM-63LE-1-C40N/30-A	SGRM-63LE-1-D40N/30-A	1
	50		SGRM-63LE-1-B50N/30-A	SGRM-63LE-1-C50N/30-A	SGRM-63LE-1-D50N/30-A	1
	63		SGRM-63LE-1-B63N/30-A	SGRM-63LE-1-C63N/30-A	SGRM-63LE-1-D63N/30-A	1
	6	100mA	SGRM-63LE-1-B6N/100-A	SGRM-63LE-1-C6N/100-A	SGRM-63LE-1-D6N/100-A	1
	10		SGRM-63LE-1-B10N/100-A	SGRM-63LE-1-C10N/100-A	SGRM-63LE-1-D10N/100-A	1
	16		SGRM-63LE-1-B16N/100-A	SGRM-63LE-1-C16N/100-A	SGRM-63LE-1-D16N/100-A	1
	20		SGRM-63LE-1-B20N/100-A	SGRM-63LE-1-C20N/100-A	SGRM-63LE-1-D20N/100-A	1
	25		SGRM-63LE-1-B25N/100-A	SGRM-63LE-1-C25N/100-A	SGRM-63LE-1-D25N/100-A	1
	32		SGRM-63LE-1-B32N/100-A	SGRM-63LE-1-C32N/100-A	SGRM-63LE-1-D32N/100-A	1
	40		SGRM-63LE-1-B40N/100-A	SGRM-63LE-1-C40N/100-A	SGRM-63LE-1-D40N/100-A	1
	50		SGRM-63LE-1-B50N/100-A	SGRM-63LE-1-C50N/100-A	SGRM-63LE-1-D50N/100-A	1
	63		SGRM-63LE-1-B63N/100-A	SGRM-63LE-1-C63N/100-A	SGRM-63LE-1-D63N/100-A	1
	6	300mA	SGRM-63LE-1-B6N/300-A	SGRM-63LE-1-C6N/300-A	SGRM-63LE-1-D6N/300-A	1
	10		SGRM-63LE-1-B10N/300-A	SGRM-63LE-1-C10N/300-A	SGRM-63LE-1-D10N/300-A	1
	16		SGRM-63LE-1-B16N/300-A	SGRM-63LE-1-C16N/300-A	SGRM-63LE-1-D16N/300-A	1
	20		SGRM-63LE-1-B20N/300-A	SGRM-63LE-1-C20N/300-A	SGRM-63LE-1-D20N/300-A	1
	25		SGRM-63LE-1-B25N/300-A	SGRM-63LE-1-C25N/300-A	SGRM-63LE-1-D25N/300-A	1
	32		SGRM-63LE-1-B32N/300-A	SGRM-63LE-1-C32N/300-A	SGRM-63LE-1-D32N/300-A	1
	40		SGRM-63LE-1-B40N/300-A	SGRM-63LE-1-C40N/300-A	SGRM-63LE-1-D40N/300-A	1
	50		SGRM-63LE-1-B50N/300-A	SGRM-63LE-1-C50N/300-A	SGRM-63LE-1-D50N/300-A	1
	63		SGRM-63LE-1-B63N/300-A	SGRM-63LE-1-C63N/300-A	SGRM-63LE-1-D63N/300-A	1



SGRM-63LE-1P+N

SGRM-63LE-RCBO	Rated current(A)	$I_{\Delta n}$	Type A 			Packing unit
			B curve	C curve	D curve	
	6	10mA	SGRM-63LE-2-B6/10-A	SGRM-63LE-2-C6/10-A	SGRM-63LE-2-D6/10-A	1
	10		SGRM-63LE-2-B10/10-A	SGRM-63LE-2-C10/10-A	SGRM-63LE-2-D10/10-A	1
	16		SGRM-63LE-2-B16/10-A	SGRM-63LE-2-C16/10-A	SGRM-63LE-2-D16/10-A	1
	20		SGRM-63LE-2-B20/10-A	SGRM-63LE-2-C20/10-A	SGRM-63LE-2-D20/10-A	1
	25		SGRM-63LE-2-B25/10-A	SGRM-63LE-2-C25/10-A	SGRM-63LE-2-D25/10-A	1
	32		SGRM-63LE-2-B32/10-A	SGRM-63LE-2-C32/10-A	SGRM-63LE-2-D32/10-A	1
	40		SGRM-63LE-2-B40/10-A	SGRM-63LE-2-C40/10-A	SGRM-63LE-2-D40/10-A	1
	50		SGRM-63LE-2-B50/10-A	SGRM-63LE-2-C50/10-A	SGRM-63LE-2-D50/10-A	1
	63		SGRM-63LE-2-B63/10-A	SGRM-63LE-2-C63/10-A	SGRM-63LE-2-D63/10-A	1
			6	30mA	SGRM-63LE-2-B6/30-A	SGRM-63LE-2-C6/30-A
10		SGRM-63LE-2-B10/30-A	SGRM-63LE-2-C10/30-A		SGRM-63LE-2-D10/30-A	1
16		SGRM-63LE-2-B16/30-A	SGRM-63LE-2-C16/30-A		SGRM-63LE-2-D16/30-A	1
20		SGRM-63LE-2-B20/30-A	SGRM-63LE-2-C20/30-A		SGRM-63LE-2-D20/30-A	1
25		SGRM-63LE-2-B25/30-A	SGRM-63LE-2-C25/30-A		SGRM-63LE-2-D25/30-A	1
32		SGRM-63LE-2-B32/30-A	SGRM-63LE-2-C32/30-A		SGRM-63LE-2-D32/30-A	1
40		SGRM-63LE-2-B40/30-A	SGRM-63LE-2-C40/30-A		SGRM-63LE-2-D40/30-A	1
50		SGRM-63LE-2-B50/30-A	SGRM-63LE-2-C50/30-A		SGRM-63LE-2-D50/30-A	1
63		SGRM-63LE-2-B63/30-A	SGRM-63LE-2-C63/30-A		SGRM-63LE-2-D63/30-A	1
		6	100mA		SGRM-63LE-2-B6/100-A	SGRM-63LE-2-C6/100-A
	10	SGRM-63LE-2-B10/100-A		SGRM-63LE-2-C10/100-A	SGRM-63LE-2-D10/100-A	1
	16	SGRM-63LE-2-B16/100-A		SGRM-63LE-2-C16/100-A	SGRM-63LE-2-D16/100-A	1
	20	SGRM-63LE-2-B20/100-A		SGRM-63LE-2-C20/100-A	SGRM-63LE-2-D20/100-A	1
	25	SGRM-63LE-2-B25/100-A		SGRM-63LE-2-C25/100-A	SGRM-63LE-2-D25/100-A	1
	32	SGRM-63LE-2-B32/100-A		SGRM-63LE-2-C32/100-A	SGRM-63LE-2-D32/100-A	1
	40	SGRM-63LE-2-B40/100-A		SGRM-63LE-2-C40/100-A	SGRM-63LE-2-D40/100-A	1
	50	SGRM-63LE-2-B50/100-A		SGRM-63LE-2-C50/100-A	SGRM-63LE-2-D50/100-A	1
	63	SGRM-63LE-2-B63/100-A		SGRM-63LE-2-C63/100-A	SGRM-63LE-2-D63/100-A	1
		6		300mA	SGRM-63LE-2-B6/300-A	SGRM-63LE-2-C6/300-A
10		SGRM-63LE-2-B10/300-A	SGRM-63LE-2-C10/300-A		SGRM-63LE-2-D10/300-A	1
16		SGRM-63LE-2-B16/300-A	SGRM-63LE-2-C16/300-A		SGRM-63LE-2-D16/300-A	1
20		SGRM-63LE-2-B20/300-A	SGRM-63LE-2-C20/300-A		SGRM-63LE-2-D20/300-A	1
25		SGRM-63LE-2-B25/300-A	SGRM-63LE-2-C25/300-A		SGRM-63LE-2-D25/300-A	1
32		SGRM-63LE-2-B32/300-A	SGRM-63LE-2-C32/300-A		SGRM-63LE-2-D32/300-A	1
40		SGRM-63LE-2-B40/300-A	SGRM-63LE-2-C40/300-A		SGRM-63LE-2-D40/300-A	1
50		SGRM-63LE-2-B50/300-A	SGRM-63LE-2-C50/300-A		SGRM-63LE-2-D50/300-A	1
63		SGRM-63LE-2-B63/300-A	SGRM-63LE-2-C63/300-A		SGRM-63LE-2-D63/300-A	1

SGRM-63LE-RCBO	Rated current(A)	$I_{\Delta n}$	Type A 			Packing unit
			B curve	C curve	D curve	
	6	10mA	SGRM-63LE-3-B6/10-A	SGRM-63LE-3-C6/10-A	SGRM-63LE-3-D6/10-A	1
	10		SGRM-63LE-3-B10/10-A	SGRM-63LE-3-C10/10-A	SGRM-63LE-3-D10/10-A	1
	16		SGRM-63LE-3-B16/10-A	SGRM-63LE-3-C16/10-A	SGRM-63LE-3-D16/10-A	1
	20		SGRM-63LE-3-B20/10-A	SGRM-63LE-3-C20/10-A	SGRM-63LE-3-D20/10-A	1
	25		SGRM-63LE-3-B25/10-A	SGRM-63LE-3-C25/10-A	SGRM-63LE-3-D25/10-A	1
	32		SGRM-63LE-3-B32/10-A	SGRM-63LE-3-C32/10-A	SGRM-63LE-3-D32/10-A	1
	40		SGRM-63LE-3-B40/10-A	SGRM-63LE-3-C40/10-A	SGRM-63LE-3-D40/10-A	1
	50		SGRM-63LE-3-B50/10-A	SGRM-63LE-3-C50/10-A	SGRM-63LE-3-D50/10-A	1
	63		SGRM-63LE-3-B63/10-A	SGRM-63LE-3-C63/10-A	SGRM-63LE-3-D63/10-A	1
	6	30mA	SGRM-63LE-3-B6/30-A	SGRM-63LE-3-C6/30-A	SGRM-63LE-3-D6/30-A	1
	10		SGRM-63LE-3-B10/30-A	SGRM-63LE-3-C10/30-A	SGRM-63LE-3-D10/30-A	1
	16		SGRM-63LE-3-B16/30-A	SGRM-63LE-3-C16/30-A	SGRM-63LE-3-D16/30-A	1
	20		SGRM-63LE-3-B20/30-A	SGRM-63LE-3-C20/30-A	SGRM-63LE-3-D20/30-A	1
	25		SGRM-63LE-3-B25/30-A	SGRM-63LE-3-C25/30-A	SGRM-63LE-3-D25/30-A	1
	32		SGRM-63LE-3-B32/30-A	SGRM-63LE-3-C32/30-A	SGRM-63LE-3-D32/30-A	1
	40		SGRM-63LE-3-B40/30-A	SGRM-63LE-3-C40/30-A	SGRM-63LE-3-D40/30-A	1
	50		SGRM-63LE-3-B50/30-A	SGRM-63LE-3-C50/30-A	SGRM-63LE-3-D50/30-A	1
	63		SGRM-63LE-3-B63/30-A	SGRM-63LE-3-C63/30-A	SGRM-63LE-3-D63/30-A	1
	6	100mA	SGRM-63LE-3-B6/100-A	SGRM-63LE-3-C6/100-A	SGRM-63LE-3-D6/100-A	1
	10		SGRM-63LE-3-B10/100-A	SGRM-63LE-3-C10/100-A	SGRM-63LE-3-D10/100-A	1
	16		SGRM-63LE-3-B16/100-A	SGRM-63LE-3-C16/100-A	SGRM-63LE-3-D16/100-A	1
	20		SGRM-63LE-3-B20/100-A	SGRM-63LE-3-C20/100-A	SGRM-63LE-3-D20/100-A	1
	25		SGRM-63LE-3-B25/100-A	SGRM-63LE-3-C25/100-A	SGRM-63LE-3-D25/100-A	1
	32		SGRM-63LE-3-B32/100-A	SGRM-63LE-3-C32/100-A	SGRM-63LE-3-D32/100-A	1
	40		SGRM-63LE-3-B40/100-A	SGRM-63LE-3-C40/100-A	SGRM-63LE-3-D40/100-A	1
	50		SGRM-63LE-3-B50/100-A	SGRM-63LE-3-C50/100-A	SGRM-63LE-3-D50/100-A	1
	63		SGRM-63LE-3-B63/100-A	SGRM-63LE-3-C63/100-A	SGRM-63LE-3-D63/100-A	1
	6	300mA	SGRM-63LE-3-B6/300-A	SGRM-63LE-3-C6/300-A	SGRM-63LE-3-D6/300-A	1
	10		SGRM-63LE-3-B10/300-A	SGRM-63LE-3-C10/300-A	SGRM-63LE-3-D10/300-A	1
	16		SGRM-63LE-3-B16/300-A	SGRM-63LE-3-C16/300-A	SGRM-63LE-3-D16/300-A	1
	20		SGRM-63LE-3-B20/300-A	SGRM-63LE-3-C20/300-A	SGRM-63LE-3-D20/300-A	1
	25		SGRM-63LE-3-B25/300-A	SGRM-63LE-3-C25/300-A	SGRM-63LE-3-D25/300-A	1
	32		SGRM-63LE-3-B32/300-A	SGRM-63LE-3-C32/300-A	SGRM-63LE-3-D32/300-A	1
	40		SGRM-63LE-3-B40/300-A	SGRM-63LE-3-C40/300-A	SGRM-63LE-3-D40/300-A	1
	50		SGRM-63LE-3-B50/300-A	SGRM-63LE-3-C50/300-A	SGRM-63LE-3-D50/300-A	1
	63		SGRM-63LE-3-B63/300-A	SGRM-63LE-3-C63/300-A	SGRM-63LE-3-D63/300-A	1



SGRM-63LE-3P

SGRM-63LE-RCBO	Rated current(A)	$I_{\Delta n}$	Type A 			Packing unit
			B curve	C curve	D curve	
	6	10mA	SGRM-63LE-3-B6N/10-A	SGRM-63LE-3-C6N/10-A	SGRM-63LE-3-D6N/10-A	1
	10		SGRM-63LE-3-B10N/10-A	SGRM-63LE-3-C10N/10-A	SGRM-63LE-3-D10N/10-A	1
	16		SGRM-63LE-3-B16N/10-A	SGRM-63LE-3-C16N/10-A	SGRM-63LE-3-D16N/10-A	1
	20		SGRM-63LE-3-B20N/10-A	SGRM-63LE-3-C20N/10-A	SGRM-63LE-3-D20N/10-A	1
	25		SGRM-63LE-3-B25N/10-A	SGRM-63LE-3-C25N/10-A	SGRM-63LE-3-D25N/10-A	1
	32		SGRM-63LE-3-B32N/10-A	SGRM-63LE-3-C32N/10-A	SGRM-63LE-3-D32N/10-A	1
	40		SGRM-63LE-3-B40N/10-A	SGRM-63LE-3-C40N/10-A	SGRM-63LE-3-D40N/10-A	1
	50		SGRM-63LE-3-B50N/10-A	SGRM-63LE-3-C50N/10-A	SGRM-63LE-3-D50N/10-A	1
	63		SGRM-63LE-3-B63N/10-A	SGRM-63LE-3-C63N/10-A	SGRM-63LE-3-D63N/10-A	1
	6	30mA	SGRM-63LE-3-B6N/30-A	SGRM-63LE-3-C6N/30-A	SGRM-63LE-3-D6N/30-A	1
	10		SGRM-63LE-3-B10N/30-A	SGRM-63LE-3-C10N/30-A	SGRM-63LE-3-D10N/30-A	1
	16		SGRM-63LE-3-B16N/30-A	SGRM-63LE-3-C16N/30-A	SGRM-63LE-3-D16N/30-A	1
	20		SGRM-63LE-3-B20N/30-A	SGRM-63LE-3-C20N/30-A	SGRM-63LE-3-D20N/30-A	1
	25		SGRM-63LE-3-B25N/30-A	SGRM-63LE-3-C25N/30-A	SGRM-63LE-3-D25N/30-A	1
	32		SGRM-63LE-3-B32N/30-A	SGRM-63LE-3-C32N/30-A	SGRM-63LE-3-D32N/30-A	1
	40		SGRM-63LE-3-B40N/30-A	SGRM-63LE-3-C40N/30-A	SGRM-63LE-3-D40N/30-A	1
	50		SGRM-63LE-3-B50N/30-A	SGRM-63LE-3-C50N/30-A	SGRM-63LE-3-D50N/30-A	1
	63		SGRM-63LE-3-B63N/30-A	SGRM-63LE-3-C63N/30-A	SGRM-63LE-3-D63N/30-A	1
	6	100mA	SGRM-63LE-3-B6N/100-A	SGRM-63LE-3-C6N/100-A	SGRM-63LE-3-D6N/100-A	1
	10		SGRM-63LE-3-B10N/100-A	SGRM-63LE-3-C10N/100-A	SGRM-63LE-3-D10N/100-A	1
	16		SGRM-63LE-3-B16N/100-A	SGRM-63LE-3-C16N/100-A	SGRM-63LE-3-D16N/100-A	1
	20		SGRM-63LE-3-B20N/100-A	SGRM-63LE-3-C20N/100-A	SGRM-63LE-3-D20N/100-A	1
	25		SGRM-63LE-3-B25N/100-A	SGRM-63LE-3-C25N/100-A	SGRM-63LE-3-D25N/100-A	1
	32		SGRM-63LE-3-B32N/100-A	SGRM-63LE-3-C32N/100-A	SGRM-63LE-3-D32N/100-A	1
	40		SGRM-63LE-3-B40N/100-A	SGRM-63LE-3-C40N/100-A	SGRM-63LE-3-D40N/100-A	1
	50		SGRM-63LE-3-B50N/100-A	SGRM-63LE-3-C50N/100-A	SGRM-63LE-3-D50N/100-A	1
	63		SGRM-63LE-3-B63N/100-A	SGRM-63LE-3-C63N/100-A	SGRM-63LE-3-D63N/100-A	1
	6	300mA	SGRM-63LE-3-B6N/300-A	SGRM-63LE-3-C6N/300-A	SGRM-63LE-3-D6N/300-A	1
	10		SGRM-63LE-3-B10N/300-A	SGRM-63LE-3-C10N/300-A	SGRM-63LE-3-D10N/300-A	1
	16		SGRM-63LE-3-B16N/300-A	SGRM-63LE-3-C16N/300-A	SGRM-63LE-3-D16N/300-A	1
	20		SGRM-63LE-3-B20N/300-A	SGRM-63LE-3-C20N/300-A	SGRM-63LE-3-D20N/300-A	1
	25		SGRM-63LE-3-B25N/300-A	SGRM-63LE-3-C25N/300-A	SGRM-63LE-3-D25N/300-A	1
	32		SGRM-63LE-3-B32N/300-A	SGRM-63LE-3-C32N/300-A	SGRM-63LE-3-D32N/300-A	1
	40		SGRM-63LE-3-B40N/300-A	SGRM-63LE-3-C40N/300-A	SGRM-63LE-3-D40N/300-A	1
	50		SGRM-63LE-3-B50N/300-A	SGRM-63LE-3-C50N/300-A	SGRM-63LE-3-D50N/300-A	1
	63		SGRM-63LE-3-B63N/300-A	SGRM-63LE-3-C63N/300-A	SGRM-63LE-3-D63N/300-A	1



SGRM-63LE-3P+N

SGRM-63LE-RCBO	Rated current(A)	$I_{\Delta n}$	Type A 			Packing unit
			B curve	C curve	D curve	
	6	10mA	SGRM-63LE-4-B6/10-A	SGRM-63LE-4-C6/10-A	SGRM-63LE-4-D6/10-A	1
	10		SGRM-63LE-4-B10/10-A	SGRM-63LE-4-C10/10-A	SGRM-63LE-4-D10/10-A	1
	16		SGRM-63LE-4-B16/10-A	SGRM-63LE-4-C16/10-A	SGRM-63LE-4-D16/10-A	1
	20		SGRM-63LE-4-B20/10-A	SGRM-63LE-4-C20/10-A	SGRM-63LE-4-D20/10-A	1
	25		SGRM-63LE-4-B25/10-A	SGRM-63LE-4-C25/10-A	SGRM-63LE-4-D25/10-A	1
	32		SGRM-63LE-4-B32/10-A	SGRM-63LE-4-C32/10-A	SGRM-63LE-4-D32/10-A	1
	40		SGRM-63LE-4-B40/10-A	SGRM-63LE-4-C40/10-A	SGRM-63LE-4-D40/10-A	1
	50		SGRM-63LE-4-B50/10-A	SGRM-63LE-4-C50/10-A	SGRM-63LE-4-D50/10-A	1
	63		SGRM-63LE-4-B63/10-A	SGRM-63LE-4-C63/10-A	SGRM-63LE-4-D63/10-A	1
	6	30mA	SGRM-63LE-4-B6/30-A	SGRM-63LE-4-C6/30-A	SGRM-63LE-4-D6/30-A	1
	10		SGRM-63LE-4-B10/30-A	SGRM-63LE-4-C10/30-A	SGRM-63LE-4-D10/30-A	1
	16		SGRM-63LE-4-B16/30-A	SGRM-63LE-4-C16/30-A	SGRM-63LE-4-D16/30-A	1
	20		SGRM-63LE-4-B20/30-A	SGRM-63LE-4-C20/30-A	SGRM-63LE-4-D20/30-A	1
	25		SGRM-63LE-4-B25/30-A	SGRM-63LE-4-C25/30-A	SGRM-63LE-4-D25/30-A	1
	32		SGRM-63LE-4-B32/30-A	SGRM-63LE-4-C32/30-A	SGRM-63LE-4-D32/30-A	1
	40		SGRM-63LE-4-B40/30-A	SGRM-63LE-4-C40/30-A	SGRM-63LE-4-D40/30-A	1
	50		SGRM-63LE-4-B50/30-A	SGRM-63LE-4-C50/30-A	SGRM-63LE-4-D50/30-A	1
	63		SGRM-63LE-4-B63/30-A	SGRM-63LE-4-C63/30-A	SGRM-63LE-4-D63/30-A	1
	6	100mA	SGRM-63LE-4-B6/100-A	SGRM-63LE-4-C6/100-A	SGRM-63LE-4-D6/100-A	1
	10		SGRM-63LE-4-B10/100-A	SGRM-63LE-4-C10/100-A	SGRM-63LE-4-D10/100-A	1
	16		SGRM-63LE-4-B16/100-A	SGRM-63LE-4-C16/100-A	SGRM-63LE-4-D16/100-A	1
	20		SGRM-63LE-4-B20/100-A	SGRM-63LE-4-C20/100-A	SGRM-63LE-4-D20/100-A	1
	25		SGRM-63LE-4-B25/100-A	SGRM-63LE-4-C25/100-A	SGRM-63LE-4-D25/100-A	1
	32		SGRM-63LE-4-B32/100-A	SGRM-63LE-4-C32/100-A	SGRM-63LE-4-D32/100-A	1
	40		SGRM-63LE-4-B40/100-A	SGRM-63LE-4-C40/100-A	SGRM-63LE-4-D40/100-A	1
	50		SGRM-63LE-4-B50/100-A	SGRM-63LE-4-C50/100-A	SGRM-63LE-4-D50/100-A	1
	63		SGRM-63LE-4-B63/100-A	SGRM-63LE-4-C63/100-A	SGRM-63LE-4-D63/100-A	1
	6	300mA	SGRM-63LE-4-B6/300-A	SGRM-63LE-4-C6/300-A	SGRM-63LE-4-D6/300-A	1
	10		SGRM-63LE-4-B10/300-A	SGRM-63LE-4-C10/300-A	SGRM-63LE-4-D10/300-A	1
	16		SGRM-63LE-4-B16/300-A	SGRM-63LE-4-C16/300-A	SGRM-63LE-4-D16/300-A	1
	20		SGRM-63LE-4-B20/300-A	SGRM-63LE-4-C20/300-A	SGRM-63LE-4-D20/300-A	1
	25		SGRM-63LE-4-B25/300-A	SGRM-63LE-4-C25/300-A	SGRM-63LE-4-D25/300-A	1
	32		SGRM-63LE-4-B32/300-A	SGRM-63LE-4-C32/300-A	SGRM-63LE-4-D32/300-A	1
	40		SGRM-63LE-4-B40/300-A	SGRM-63LE-4-C40/300-A	SGRM-63LE-4-D40/300-A	1
	50		SGRM-63LE-4-B50/300-A	SGRM-63LE-4-C50/300-A	SGRM-63LE-4-D50/300-A	1
	63		SGRM-63LE-4-B63/300-A	SGRM-63LE-4-C63/300-A	SGRM-63LE-4-D63/300-A	1



SGRM-63LE-4P

1. Curves

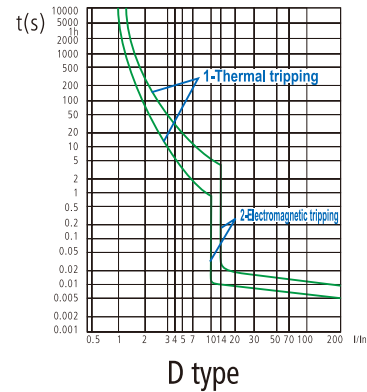
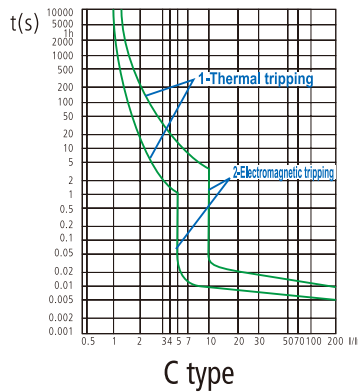
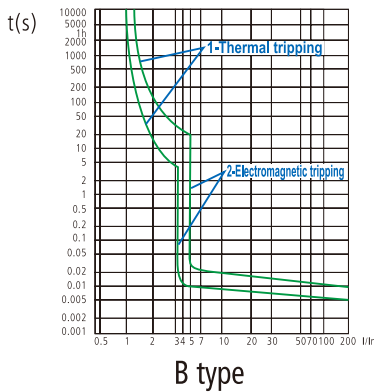

2. Wiring

The suitable conductors should be used for connection, see table below for relative parameters.

Rated current I_n (A)	Cross section area s (mm ²)	Tightening torque (N.m)
6	1	2
10	1.5	2
16-20	2.5	2
25	4	2
32	6	2
40-50	10	2
63	16	2

3. Types

Both RCCBs and RCBOs are divided into types depending on the operating function:

Type AC : For which tripping is ensured for residual sinusoidal alternating currents, whether suddenly applied or slowly rising.

Type A : For which tripping is ensured for residual sinusoidal alternating currents and residual pulsating direct currents, whether suddenly applied or slowly rising.

4. Tripping sensitivity data

RCCBs and RCBOs with a rated residual current of maximum 30mA are used for personnel, material and fire protection, as well as for protection against direct contact.



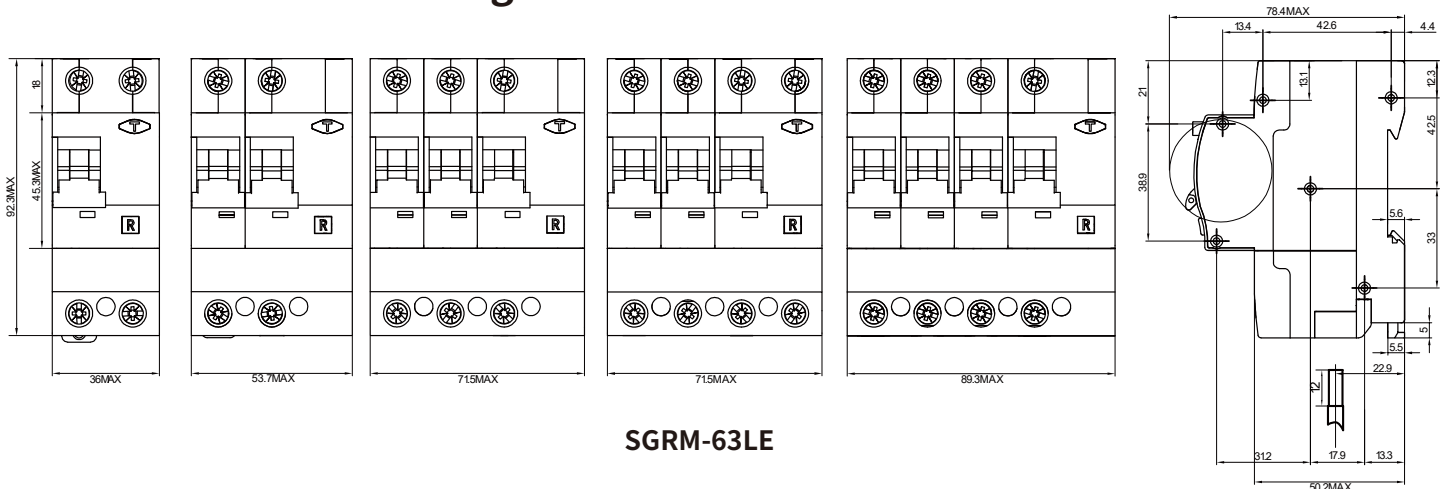

RCCBs and RCBOs with a rated residual current of maximum 300mA are used as preventative fire protection in case of insulation faults.

RCCBs and RCBOs with a rated residual current of 100mA co-ordinated with the earth system according to the formula $I_{\Delta n} < 50/R$, to provide protection against indirect contacts.





5. Overall and mounting dimensions



Products Overview of Circuit Breakers

Product name					
Product range	MGB-63Me	MGB-63Ne	MGB-63Se	MGB-63M	MGB-63H
Product picture					
Standard	IEC/EN 60898-1				
Number of poles	1,2,3,4 (1P+N),(3P+N)				
Electrical characteristics					
Rated current(A) In	1~63				
Rated voltage(V)	230/400VAC				
AC rated short-circuit capacity(KA)					
IEC60898 standard (Icn)	6	4.5	3	6	10
IEC60947-2	—	—	—	—	—
Tripping curve	C	C	C	B,C,D	B,C,D
Type	AC	AC	AC	AC	AC
Electrical auxiliaries	Auxiliary contact, Alarm contact , Shunt trip, Over/under voltage trip				
Catalogue page No.	47-50			51-56	

Products Overview of Circuit Breakers

Product name	DC MCB	DPN MCB	HR MCB	ISOLATING SWITCH			
Product range	MGB-63M-DC	EP-DPN	EPB-125H	MGI-R			
Product picture							
Standard	IEC/EN 60947-2	IEC/EN 60898-1	IEC/EN 60898-1 IEC/EN 60947-2	IEC/EN 60947-3			
Number of poles	1,2,3,4	1P+N	1,2,3,4	1,2,3,4			
Electrical characteristics							
Rated current(A) In	1~63	2~32	40~125	16~100			
Rated voltage(V)	250-1000VDC	240VAC	240VAC 415VAC	240VAC 415VAC			
AC rated short-circuit capacity(kA)							
Breaking capacity (Icn/Icu) kA	6	3	4.5	6	IEC-60898-1	IEC-60947-2	—
					6	10	
Tripping curve	8-12In	B,C		B,C,D	8-12In	—	
Type	DC	AC		AC		AC	
Electrical auxiliaries	—	Auxiliary contact Alarm contact Shunt trip Over/under voltage trip		Auxiliary contact Alarm contact Shunt trip Over/under voltage trip		—	
Catalogue page No.	57-60	61-65		64-66		67-69	

MGB-63Me/Ne/Se Series

Miniature Circuit Breaker

Technical data

Standard	EN/ IEC60898-1
Breaking capacity	3kA,4.5kA,6kA
Protection	Against overload and short circuit
Rated current In	1,2,3,4,6, 10, 13, 16,20,25,32,40,50,63A
Rated voltage AC:	1 Pole 240V; 2,3,4 Pole 415V Rated insulation voltage Ui: 500V Rated impulse withstand voltage Uimp: 4kV Energy limiting :class 3 for 6kA,class 1 for 4.5kA/3kA
Ambient temperature (°C)	-5~+40
Characteristic	Thermal operating limit: (1.13-1.45) x In Magnetic operating: C: (5-10) x In
Number of poles	1P, 1P+N,2P,3P,3P+N and 4P
Type of trip	Thermal / magnetic release
Type of terminal	Pin type
Terminal capacity	16mm ² flexible or 25mm ² rigid up to 25A ratings 25mm ² flexible or 35mm ² rigid from 32A to 63A ratings
Protection degree	IP20
Installation	Mounting on 35mm DIN rail
Width	17.8mm per pole



MGB-63Me-1P



MGB-63Me-2P



MGB-63Me-3P



MGB-63Me-4P

Economic MCB

Rated current(A)	C curve			Packing unit
	6kA	4.5kA	3kA	
1	MGB-63Me/1-C1	MGB-63Ne/1-C1	MGB-63Se/1-C1	12
2	MGB-63Me/1-C2	MGB-63Ne/1-C2	MGB-63Se/1-C2	12
3	MGB-63Me/1-C3	MGB-63Ne/1-C3	MGB-63Se/1-C3	12
4	MGB-63Me/1-C4	MGB-63Ne/1-C4	MGB-63Se/1-C4	12
6	MGB-63Me/1-C6	MGB-63Ne/1-C6	MGB-63Se/1-C6	12
10	MGB-63Me/1-C10	MGB-63Ne/1-C10	MGB-63Se/1-C10	12
13	MGB-63Me/1-C13	MGB-63Ne/1-C13	MGB-63Se/1-C13	12
16	MGB-63Me/1-C16	MGB-63Ne/1-C16	MGB-63Se/1-C16	12
20	MGB-63Me/1-C20	MGB-63Ne/1-C20	MGB-63Se/1-C20	12
25	MGB-63Me/1-C25	MGB-63Ne/1-C25	MGB-63Se/1-C25	12
32	MGB-63Me/1-C32	MGB-63Ne/1-C32	MGB-63Se/1-C32	12
40	MGB-63Me/1-C40	MGB-63Ne/1-C40	MGB-63Se/1-C40	12
50	MGB-63Me/1-C50	MGB-63Ne/1-C50	MGB-63Se/1-C50	12
63	MGB-63Me/1-C63	MGB-63Ne/1-C63	MGB-63Se/1-C63	12
1	MGB-63Me/1-C1N	MGB-63Ne/1-C1N	MGB-63Se/1-C1N	6
2	MGB-63Me/1-C2N	MGB-63Ne/1-C2N	MGB-63Se/1-C2N	6
3	MGB-63Me/1-C3N	MGB-63Ne/1-C3N	MGB-63Se/1-C3N	6
4	MGB-63Me/1-C4N	MGB-63Ne/1-C4N	MGB-63Se/1-C4N	6
6	MGB-63Me/1-C6N	MGB-63Ne/1-C6N	MGB-63Se/1-C6N	6
10	MGB-63Me/1-C10N	MGB-63Ne/1-C10N	MGB-63Se/1-C10N	6
13	MGB-63Me/1-C13N	MGB-63Ne/1-C13N	MGB-63Se/1-C13N	6
16	MGB-63Me/1-C16N	MGB-63Ne/1-C16N	MGB-63Se/1-C16N	6
20	MGB-63Me/1-C20N	MGB-63Ne/1-C20N	MGB-63Se/1-C20N	6
25	MGB-63Me/1-C25N	MGB-63Ne/1-C25N	MGB-63Se/1-C25N	6
32	MGB-63Me/1-C32N	MGB-63Ne/1-C32N	MGB-63Se/1-C32N	6
40	MGB-63Me/1-C40N	MGB-63Ne/1-C40N	MGB-63Se/1-C40N	6
50	MGB-63Me/1-C50N	MGB-63Ne/1-C50N	MGB-63Se/1-C50N	6
63	MGB-63Me/1-C63N	MGB-63Ne/1-C63N	MGB-63Se/1-C63N	6
1	MGB-63Me/2-C1	MGB-63Ne/2-C1	MGB-63Se/2-C1	6
2	MGB-63Me/2-C2	MGB-63Ne/2-C2	MGB-63Se/2-C2	6
3	MGB-63Me/2-C3	MGB-63Ne/2-C3	MGB-63Se/2-C3	6
4	MGB-63Me/2-C4	MGB-63Ne/2-C4	MGB-63Se/2-C4	6
6	MGB-63Me/2-C6	MGB-63Ne/2-C6	MGB-63Se/2-C6	6
10	MGB-63Me/2-C10	MGB-63Ne/2-C10	MGB-63Se/2-C10	6
13	MGB-63Me/2-C13	MGB-63Ne/2-C13	MGB-63Se/2-C13	6
16	MGB-63Me/2-C16	MGB-63Ne/2-C16	MGB-63Se/2-C16	6
20	MGB-63Me/2-C20	MGB-63Ne/2-C20	MGB-63Se/2-C20	6
25	MGB-63Me/2-C25	MGB-63Ne/2-C25	MGB-63Se/2-C25	6
32	MGB-63Me/2-C32	MGB-63Ne/2-C32	MGB-63Se/2-C32	6
40	MGB-63Me/2-C40	MGB-63Ne/2-C40	MGB-63Se/2-C40	6
50	MGB-63Me/2-C50	MGB-63Ne/2-C50	MGB-63Se/2-C50	6
63		MGB-63Ne/2-C63	MGB-63Se/2-C63	6



MGB-63Me-1P



MGB-63Me-1P+N



MGB-63Me-2P

Economic MCB

Rated current(A)	C curve			Packing unit
	6kA	4.5kA	3kA	



MGB-63Me-3P



MGB-63Me-3P+N



MGB-63Me-4P

1	MGB-63Me/3-C1	MGB-63Ne/3-C1	MGB-63Se/3-C1	4
2	MGB-63Me/3-C2	MGB-63Ne/3-C2	MGB-63Se/3-C2	4
3	MGB-63Me/3-C3	MGB-63Ne/3-C3	MGB-63Se/3-C3	4
4	MGB-63Me/3-C4	MGB-63Ne/3-C4	MGB-63Se/3-C4	4
6	MGB-63Me/3-C6	MGB-63Ne/3-C6	MGB-63Se/3-C6	4
10	MGB-63Me/3-C10	MGB-63Ne/3-C10	MGB-63Se/3-C10	4
13	MGB-63Me/3-C13	MGB-63Ne/3-C13	MGB-63Se/3-C13	4
16	MGB-63Me/3-C16	MGB-63Ne/3-C16	MGB-63Se/3-C16	4
20	MGB-63Me/3-C20	MGB-63Ne/3-C20	MGB-63Se/3-C20	4
25	MGB-63Me/3-C25	MGB-63Ne/3-C25	MGB-63Se/3-C25	4
32	MGB-63Me/3-C32	MGB-63Ne/3-C32	MGB-63Se/3-C32	4
40	MGB-63Me/3-C40	MGB-63Ne/3-C40	MGB-63Se/3-C40	4
50	MGB-63Me/3-C50	MGB-63Ne/3-C50	MGB-63Se/3-C50	4
63	MGB-63Me/3-C63	MGB-63Ne/3-C63	MGB-63Se/3-C63	4
<hr/>				
1	MGB-63Me/3-C1N	MGB-63Ne/3-C1N	MGB-63Se/3-C1N	3
2	MGB-63Me/3-C2N	MGB-63Ne/3-C2N	MGB-63Se/3-C2N	3
3	MGB-63Me/3-C3N	MGB-63Ne/3-C3N	MGB-63Se/3-C3N	3
4	MGB-63Me/3-C4N	MGB-63Ne/3-C4N	MGB-63Se/3-C4N	3
6	MGB-63Me/3-C6N	MGB-63Ne/3-C6N	MGB-63Se/3-C6N	3
10	MGB-63Me/3-C10N	MGB-63Ne/3-C10N	MGB-63Se/3-C10N	3
13	MGB-63Me/3-C13N	MGB-63Ne/3-C13N	MGB-63Se/3-C13N	3
16	MGB-63Me/3-C16N	MGB-63Ne/3-C16N	MGB-63Se/3-C16N	3
20	MGB-63Me/3-C20N	MGB-63Ne/3-C20N	MGB-63Se/3-C20N	3
25	MGB-63Me/3-C25N	MGB-63Ne/3-C25N	MGB-63Se/3-C25N	3
32	MGB-63Me/3-C32N	MGB-63Ne/3-C32N	MGB-63Se/3-C32N	3
40	MGB-63Me/3-C40N	MGB-63Ne/3-C40N	MGB-63Se/3-C40N	3
50	MGB-63Me/3-C50N	MGB-63Ne/3-C50N	MGB-63Se/3-C50N	3
63	MGB-63Me/3-C63N	MGB-63Ne/3-C63N	MGB-63Se/3-C63N	3
<hr/>				
1	MGB-63Me/4-C1	MGB-63Ne/4-C1	MGB-63Se/4-C1	3
2	MGB-63Me/4-C2	MGB-63Ne/4-C2	MGB-63Se/4-C2	3
3	MGB-63Me/4-C3	MGB-63Ne/4-C3	MGB-63Se/4-C3	3
4	MGB-63Me/4-C4	MGB-63Ne/4-C4	MGB-63Se/4-C4	3
6	MGB-63Me/4-C6	MGB-63Ne/4-C6	MGB-63Se/4-C6	3
10	MGB-63Me/4-C10	MGB-63Ne/4-C10	MGB-63Se/4-C10	3
13	MGB-63Me/4-C13	MGB-63Ne/4-C13	MGB-63Se/4-C13	3
16	MGB-63Me/4-C16	MGB-63Ne/4-C16	MGB-63Se/4-C16	3
20	MGB-63Me/4-C20	MGB-63Ne/4-C20	MGB-63Se/4-C20	3
25	MGB-63Me/4-C25	MGB-63Ne/4-C25	MGB-63Se/4-C25	3
32	MGB-63Me/4-C32	MGB-63Ne/4-C32	MGB-63Se/4-C32	3
40	MGB-63Me/4-C40	MGB-63Ne/4-C40	MGB-63Se/4-C40	3
50	MGB-63Me/4-C50	MGB-63Ne/4-C50	MGB-63Se/4-C50	3
63	MGB-63Me/4-C63	MGB-63Ne/4-C63	MGB-63Se/4-C63	3

1. Curves

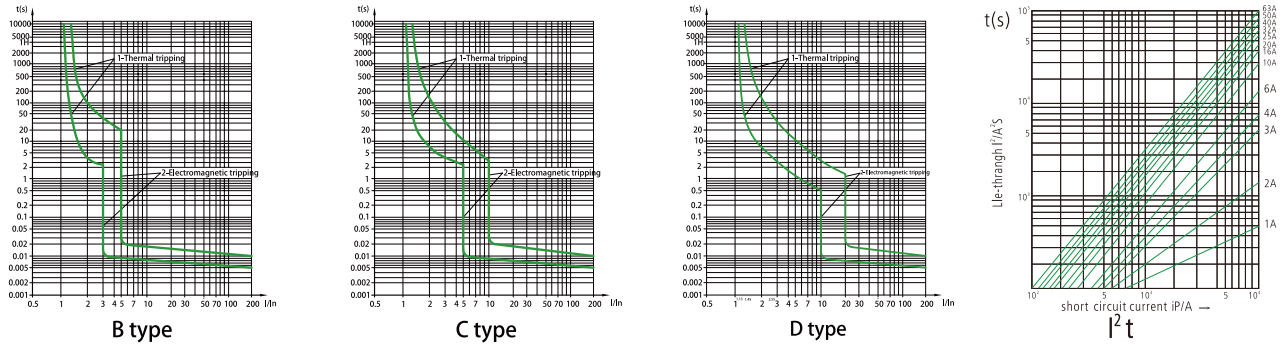

2. Overcurrent protecting characteristics

No	Rated current of release(A)	Initial state	Test current	Specified time	Result to be obtained	Remarks
1	1-63	cold state	1.13I _n	t ≤ 1 h	Non-trip	
2	1-63	upon the previous test	1.45I _n	t < 1 h	trip	Setting current up to specified value steadily in 5S
3	I _n ≤ 32	cold state	2.55I _n	1s < t < 60s	trip	
	I _n > 32	cold state	2.55I _n	1s < t < 120s	trip	
4	1-63	cold state	5I _n	t ≤ 0.1s	Non-trip	C type
	1-63	cold state	10I _n	t < 1.1s	trip	C type

3. Endurance(operations)

Category	Operations	Operation frequency	Rated current
Electrical endurance	8000	240/h	0.5-32
		120/h	40-63
Mechanical endurance	20000	240/h	0.5-63

4.Features

Much higher short circuit breaking capacity, Dual-connection convenient for both standard busbar and conductor connection. Improved safety of operators offered by special design from terminals. Much longer service life thanks to energy-storage operating mechanism. Enclosure and functional parts made from imported plastics with flame-retardant, heat-resistant, and impulse-proof properties. Higher current-limiting capacity ensuring a cost-effective range of products. Different handle color for different rated current with contactor condition indicator.

5. Overall and mounting dimensions

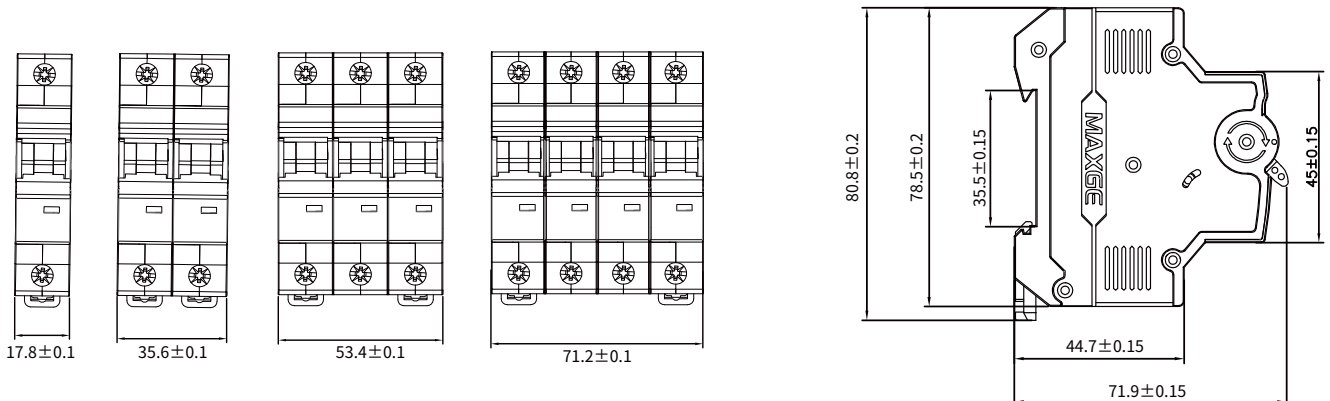

MGB-63Me/MGB-63Se/MGB-63Ne

MGB-63M/H Series

Miniature Circuit Breaker

Technical data

Standard	EN/ IEC60898-1
Breaking capacity	6kA/10kA
Protection	Against overload and short circuit
Rated current In	1,2,3,4,6, 10, 13, 16,20,25,32,40,50,63A
Rated voltage	AC: 1,2,3,4 pole 230/400V Rated insulation voltage Ui: 500V Rated impulse withstand voltage Uimp: 4kV Energy limiting :class 3
Ambient temperature (°C)	-5~+40
Characteristic	Thermal operating limit: (1.13-1.45) x In Magnetic operating: B: (3-5) x In C:(5-10) x In D: (10-20) x In
Number of poles	1P, 1P+N, 2P, 3P, 3P+N and 4P
Type of trip	Thermal/magnetic release
Type of terminal	Lug type and Pin type
Terminal capacity	16mm ² flexible or 25mm ² rigid up to 25A ratings 25mm ² flexible or 35mm ² rigid from 32A to 63A ratings
Protection degree	IP20
Installation	Mounting on 35mm DIN rail
Width	17.8mm per pole



MGB-63M-1P



MGB-63M-2P



MGB-63M-3P



MGB-63M-4P

MGB-63M MCB



MGB-63M-1P



MGB-63M-1P+N



MGB-63M-2P

	Rated current(A)	B curve	C curve	D curve	Packing unit
1		MGB-63M/1-B1	MGB-63M/1-C1	MGB-63M/1-D1	12
2		MGB-63M/1-B2	MGB-63M/1-C2	MGB-63M/1-D2	12
3		MGB-63M/1-B3	MGB-63M/1-C3	MGB-63M/1-D3	12
4		MGB-63M/1-B4	MGB-63M/1-C4	MGB-63M/1-D4	12
6		MGB-63M/1-B6	MGB-63M/1-C6	MGB-63M/1-D6	12
10		MGB-63M/1-B10	MGB-63M/1-C10	MGB-63M/1-D10	12
13		MGB-63M/1-B13	MGB-63M/1-C13	MGB-63M/1-D13	12
16		MGB-63M/1-B16	MGB-63M/1-C16	MGB-63M/1-D16	12
20		MGB-63M/1-B20	MGB-63M/1-C20	MGB-63M/1-D20	12
25		MGB-63M/1-B25	MGB-63M/1-C25	MGB-63M/1-D25	12
32		MGB-63M/1-B32	MGB-63M/1-C32	MGB-63M/1-D32	12
40		MGB-63M/1-B40	MGB-63M/1-C40	MGB-63M/1-D40	12
50		MGB-63M/1-B50	MGB-63M/1-C50	MGB-63M/1-D50	12
63		MGB-63M/1-B63	MGB-63M/1-C63	MGB-63M/1-D63	12
<hr/>					
1		MGB-63M/1-B1N	MGB-63M/1-C1N	MGB-63M/1-D1N	6
2		MGB-63M/1-B2N	MGB-63M/1-C2N	MGB-63M/1-D2N	6
3		MGB-63M/1-B3N	MGB-63M/1-C3N	MGB-63M/1-D3N	6
4		MGB-63M/1-B4N	MGB-63M/1-C4N	MGB-63M/1-D4N	6
6		MGB-63M/1-B6N	MGB-63M/1-C6N	MGB-63M/1-D6N	6
10		MGB-63M/1-B10N	MGB-63M/1-C10N	MGB-63M/1-D10N	6
13		MGB-63M/1-B13N	MGB-63M/1-C13N	MGB-63M/1-D13N	6
16		MGB-63M/1-B16N	MGB-63M/1-C16N	MGB-63M/1-D16N	6
20		MGB-63M/1-B20N	MGB-63M/1-C20N	MGB-63M/1-D20N	6
25		MGB-63M/1-B25N	MGB-63M/1-C25N	MGB-63M/1-D25N	6
32		MGB-63M/1-B32N	MGB-63M/1-C32N	MGB-63M/1-D32N	6
40		MGB-63M/1-B40N	MGB-63M/1-C40N	MGB-63M/1-D40N	6
50		MGB-63M/1-B50N	MGB-63M/1-C50N	MGB-63M/1-D50N	6
63		MGB-63M/1-B63N	MGB-63M/1-C63N	MGB-63M/1-D63N	6
<hr/>					
1		MGB-63M/2-B1	MGB-63M/2-C1	MGB-63M/2-D1	6
2		MGB-63M/2-B2	MGB-63M/2-C2	MGB-63M/2-D2	6
3		MGB-63M/2-B3	MGB-63M/2-C3	MGB-63M/2-D3	6
4		MGB-63M/2-B4	MGB-63M/2-C4	MGB-63M/2-D4	6
6		MGB-63M/2-B6	MGB-63M/2-C6	MGB-63M/2-D6	6
10		MGB-63M/2-B10	MGB-63M/2-C10	MGB-63M/2-D10	6
13		MGB-63M/2-B13	MGB-63M/2-C13	MGB-63M/2-D13	6
16		MGB-63M/2-B16	MGB-63M/2-C16	MGB-63M/2-D16	6
20		MGB-63M/2-B20	MGB-63M/2-C20	MGB-63M/2-D20	6
25		MGB-63M/2-B25	MGB-63M/2-C25	MGB-63M/2-D25	6
32		MGB-63M/2-B32	MGB-63M/2-C32	MGB-63M/2-D32	6
40		MGB-63M/2-B40	MGB-63M/2-C40	MGB-63M/2-D40	6
50		MGB-63M/2-B50	MGB-63M/2-C50	MGB-63M/2-D50	6
63		MGB-63M/2-B63	MGB-63M/2-C63	MGB-63M/2-D63	6

MGB-63M MCB

Rated current(A)	B curve	C curve	D curve	Packing unit
------------------	---------	---------	---------	--------------



MGB-63M-3P



MGB-63M-3P+N



MGB-63M-4P

1	MGB-63M/3-B1	MGB-63M/3-C1	MGB-63M/3-D1	4
2	MGB-63M/3-B2	MGB-63M/3-C2	MGB-63M/3-D2	4
3	MGB-63M/3-B3	MGB-63M/3-C3	MGB-63M/3-D3	4
4	MGB-63M/3-B4	MGB-63M/3-C4	MGB-63M/3-D4	4
6	MGB-63M/3-B6	MGB-63M/3-C6	MGB-63M/3-D6	4
10	MGB-63M/3-B10	MGB-63M/3-C10	MGB-63M/3-D10	4
13	MGB-63M/3-B13	MGB-63M/3-C13	MGB-63M/3-D13	4
16	MGB-63M/3-B16	MGB-63M/3-C16	MGB-63M/3-D16	4
20	MGB-63M/3-B20	MGB-63M/3-C20	MGB-63M/3-D20	4
25	MGB-63M/3-B25	MGB-63M/3-C25	MGB-63M/3-D25	4
32	MGB-63M/3-B32	MGB-63M/3-C32	MGB-63M/3-D32	4
40	MGB-63M/3-B40	MGB-63M/3-C40	MGB-63M/3-D40	4
50	MGB-63M/3-B50	MGB-63M/3-C50	MGB-63M/3-D50	4
63	MGB-63M/3-B63	MGB-63M/3-C63	MGB-63M/3-D63	4

1	MGB-63M/3-B1N	MGB-63M/3-C1N	MGB-63M/3-D1N	3
2	MGB-63M/3-B2N	MGB-63M/3-C2N	MGB-63M/3-D2N	3
3	MGB-63M/3-B3N	MGB-63M/3-C3N	MGB-63M/3-D3N	3
4	MGB-63M/3-B4N	MGB-63M/3-C4N	MGB-63M/3-D4N	3
6	MGB-63M/3-B6N	MGB-63M/3-C6N	MGB-63M/3-D6N	3
10	MGB-63M/3-B10N	MGB-63M/3-C10N	MGB-63M/3-D10N	3
13	MGB-63M/3-B13N	MGB-63M/3-C13N	MGB-63M/3-D13N	3
16	MGB-63M/3-B16N	MGB-63M/3-C16N	MGB-63M/3-D16N	3
20	MGB-63M/3-B20N	MGB-63M/3-C20N	MGB-63M/3-D20N	3
25	MGB-63M/3-B25N	MGB-63M/3-C25N	MGB-63M/3-D25N	3
32	MGB-63M/3-B32N	MGB-63M/3-C32N	MGB-63M/3-D32N	3
40	MGB-63M/3-B40N	MGB-63M/3-C40N	MGB-63M/3-D40N	3
50	MGB-63M/3-B50N	MGB-63M/3-C50N	MGB-63M/3-D50N	3
63	MGB-63M/3-B63N	MGB-63M/3-C63N	MGB-63M/3-D63N	3

1	MGB-63M/4-B1	MGB-63M/4-C1	MGB-63M/4-D1	3
2	MGB-63M/4-B2	MGB-63M/4-C2	MGB-63M/4-D2	3
3	MGB-63M/4-B3	MGB-63M/4-C3	MGB-63M/4-D3	3
4	MGB-63M/4-B4	MGB-63M/4-C4	MGB-63M/4-D4	3
6	MGB-63M/4-B6	MGB-63M/4-C6	MGB-63M/4-D6	3
10	MGB-63M/4-B10	MGB-63M/4-C10	MGB-63M/4-D10	3
13	MGB-63M/4-B13	MGB-63M/4-C13	MGB-63M/4-D13	3
16	MGB-63M/4-B16	MGB-63M/4-C16	MGB-63M/4-D16	3
20	MGB-63M/4-B20	MGB-63M/4-C20	MGB-63M/4-D20	3
25	MGB-63M/4-B25	MGB-63M/4-C25	MGB-63M/4-D25	3
32	MGB-63M/4-B32	MGB-63M/4-C32	MGB-63M/4-D32	3
40	MGB-63M/4-B40	MGB-63M/4-C40	MGB-63M/4-D40	3
50	MGB-63M/4-B50	MGB-63M/4-C50	MGB-63M/4-D50	3
63	MGB-63M/4-B63	MGB-63M/4-C63	MGB-63M/4-D63	3

MGB-63H MCB

Rated current(A)	B curve	C curve	D curve	Packing unit
------------------	---------	---------	---------	--------------



MGB-63H-1P



MGB-63H-1P+N



MGB-63H-2P

1	MGB-63H/1-B1	MGB-63H/1-C1	MGB-63H/1-D1	12
2	MGB-63H/1-B2	MGB-63H/1-C2	MGB-63H/1-D2	12
3	MGB-63H/1-B3	MGB-63H/1-C3	MGB-63H/1-D3	12
4	MGB-63H/1-B4	MGB-63H/1-C4	MGB-63H/1-D4	12
6	MGB-63H/1-B6	MGB-63H/1-C6	MGB-63H/1-D6	12
10	MGB-63H/1-B10	MGB-63H/1-C10	MGB-63H/1-D10	12
13	MGB-63H/1-B13	MGB-63H/1-C13	MGB-63H/1-D13	12
16	MGB-63H/1-B16	MGB-63H/1-C16	MGB-63H/1-D16	12
20	MGB-63H/1-B20	MGB-63H/1-C20	MGB-63H/1-D20	12
25	MGB-63H/1-B25	MGB-63H/1-C25	MGB-63H/1-D25	12
32	MGB-63H/1-B32	MGB-63H/1-C32	MGB-63H/1-D32	12
40	MGB-63H/1-B40	MGB-63H/1-C40	MGB-63H/1-D40	12
50	MGB-63H/1-B50	MGB-63H/1-C50	MGB-63H/1-D50	12
63	MGB-63H/1-B63	MGB-63H/1-C63	MGB-63H/1-D63	12
<hr/>				
1	MGB-63H/1-B1N	MGB-63H/1-C1N	MGB-63H/1-D1N	6
2	MGB-63H/1-B2N	MGB-63H/1-C2N	MGB-63H/1-D2N	6
3	MGB-63H/1-B3N	MGB-63H/1-C3N	MGB-63H/1-D3N	6
4	MGB-63H/1-B4N	MGB-63H/1-C4N	MGB-63H/1-D4N	6
6	MGB-63H/1-B6N	MGB-63H/1-C6N	MGB-63H/1-D6N	6
10	MGB-63H/1-B10N	MGB-63H/1-C10N	MGB-63H/1-D10N	6
13	MGB-63H/1-B13N	MGB-63H/1-C13N	MGB-63H/1-D13N	6
16	MGB-63H/1-B16N	MGB-63H/1-C16N	MGB-63H/1-D16N	6
20	MGB-63H/1-B20N	MGB-63H/1-C20N	MGB-63H/1-D20N	6
25	MGB-63H/1-B25N	MGB-63H/1-C25N	MGB-63H/1-D25N	6
32	MGB-63H/1-B32N	MGB-63H/1-C32N	MGB-63H/1-D32N	6
40	MGB-63H/1-B40N	MGB-63H/1-C40N	MGB-63H/1-D40N	6
50	MGB-63H/1-B50N	MGB-63H/1-C50N	MGB-63H/1-D50N	6
63	MGB-63H/1-B63N	MGB-63H/1-C63N	MGB-63H/1-D63N	6
<hr/>				
1	MGB-63H/2-B1	MGB-63H/2-C1	MGB-63H/2-D1	6
2	MGB-63H/2-B2	MGB-63H/2-C2	MGB-63H/2-D2	6
3	MGB-63H/2-B3	MGB-63H/2-C3	MGB-63H/2-D3	6
4	MGB-63H/2-B4	MGB-63H/2-C4	MGB-63H/2-D4	6
6	MGB-63H/2-B6	MGB-63H/2-C6	MGB-63H/2-D6	6
10	MGB-63H/2-B10	MGB-63H/2-C10	MGB-63H/2-D10	6
13	MGB-63H/2-B13	MGB-63H/2-C13	MGB-63H/2-D13	6
16	MGB-63H/2-B16	MGB-63H/2-C16	MGB-63H/2-D16	6
20	MGB-63H/2-B20	MGB-63H/2-C20	MGB-63H/2-D20	6
25	MGB-63H/2-B25	MGB-63H/2-C25	MGB-63H/2-D25	6
32	MGB-63H/2-B32	MGB-63H/2-C32	MGB-63H/2-D32	6
40	MGB-63H/2-B40	MGB-63H/2-C40	MGB-63H/2-D40	6
50	MGB-63H/2-B50	MGB-63H/2-C50	MGB-63H/2-D50	6
63	MGB-63H/2-B63	MGB-63H/2-C63	MGB-63H/2-D63	6

MGB-63H MCB

Rated current(A)	B curve	C curve	D curve	Packing unit
------------------	---------	---------	---------	--------------



MGB-63H-3P



MGB-63H-3P+N



MGB-63H-4P

1	MGB-63H/3-B1	MGB-63H/3-C1	MGB-63H/3-D1	4
2	MGB-63H/3-B2	MGB-63H/3-C2	MGB-63H/3-D2	4
3	MGB-63H/3-B3	MGB-63H/3-C3	MGB-63H/3-D3	4
4	MGB-63H/3-B4	MGB-63H/3-C4	MGB-63H/3-D4	4
6	MGB-63H/3-B6	MGB-63H/3-C6	MGB-63H/3-D6	4
10	MGB-63H/3-B10	MGB-63H/3-C10	MGB-63H/3-D10	4
13	MGB-63H/3-B13	MGB-63H/3-C13	MGB-63H/3-D13	4
16	MGB-63H/3-B16	MGB-63H/3-C16	MGB-63H/3-D16	4
20	MGB-63H/3-B20	MGB-63H/3-C20	MGB-63H/3-D20	4
25	MGB-63H/3-B25	MGB-63H/3-C25	MGB-63H/3-D25	4
32	MGB-63H/3-B32	MGB-63H/3-C32	MGB-63H/3-D32	4
40	MGB-63H/3-B40	MGB-63H/3-C40	MGB-63H/3-D40	4
50	MGB-63H/3-B50	MGB-63H/3-C50	MGB-63H/3-D50	4
63	MGB-63H/3-B63	MGB-63H/3-C63	MGB-63H/3-D63	4
1	MGB-63H/3-B1N	MGB-63H/3-C1N	MGB-63H/3-D1N	3
2	MGB-63H/3-B2N	MGB-63H/3-C2N	MGB-63H/3-D2N	3
3	MGB-63H/3-B3N	MGB-63H/3-C3N	MGB-63H/3-D3N	3
4	MGB-63H/3-B4N	MGB-63H/3-C4N	MGB-63H/3-D4N	3
6	MGB-63H/3-B6N	MGB-63H/3-C6N	MGB-63H/3-D6N	3
10	MGB-63H/3-B10N	MGB-63H/3-C10N	MGB-63H/3-D10N	3
13	MGB-63H/3-B13N	MGB-63H/3-C13N	MGB-63H/3-D13N	3
16	MGB-63H/3-B16N	MGB-63H/3-C16N	MGB-63H/3-D16N	3
20	MGB-63H/3-B20N	MGB-63H/3-C20N	MGB-63H/3-D20N	3
25	MGB-63H/3-B25N	MGB-63H/3-C25N	MGB-63H/3-D25N	3
32	MGB-63H/3-B32N	MGB-63H/3-C32N	MGB-63H/3-D32N	3
40	MGB-63H/3-B40N	MGB-63H/3-C40N	MGB-63H/3-D40N	3
50	MGB-63H/3-B50N	MGB-63H/3-C50N	MGB-63H/3-D50N	3
63	MGB-63H/3-B63N	MGB-63H/3-C63N	MGB-63H/3-D63N	3
1	MGB-63H/4-B1	MGB-63H/4-C1	MGB-63H/4-D1	3
2	MGB-63H/4-B2	MGB-63H/4-C2	MGB-63H/4-D2	3
3	MGB-63H/4-B3	MGB-63H/4-C3	MGB-63H/4-D3	3
4	MGB-63H/4-B4	MGB-63H/4-C4	MGB-63H/4-D4	3
6	MGB-63H/4-B6	MGB-63H/4-C6	MGB-63H/4-D6	3
10	MGB-63H/4-B10	MGB-63H/4-C10	MGB-63H/4-D10	3
13	MGB-63H/4-B13	MGB-63H/4-C13	MGB-63H/4-D13	3
16	MGB-63H/4-B16	MGB-63H/4-C16	MGB-63H/4-D16	3
20	MGB-63H/4-B20	MGB-63H/4-C20	MGB-63H/4-D20	3
25	MGB-63H/4-B25	MGB-63H/4-C25	MGB-63H/4-D25	3
32	MGB-63H/4-B32	MGB-63H/4-C32	MGB-63H/4-D32	3
40	MGB-63H/4-B40	MGB-63H/4-C40	MGB-63H/4-D40	3
50	MGB-63H/4-B50	MGB-63H/4-C50	MGB-63H/4-D50	3
63	MGB-63H/4-B63	MGB-63H/4-C63	MGB-63H/4-D63	3

1. Curves

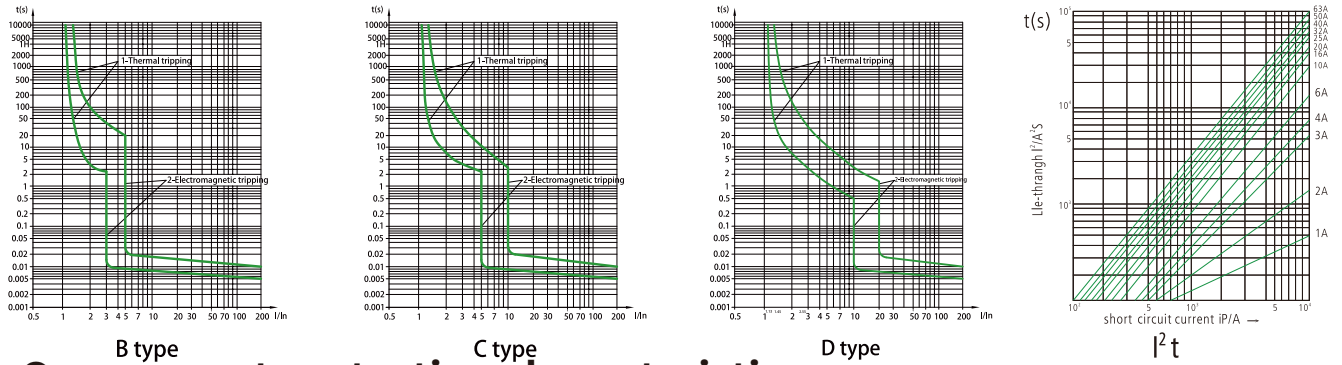

2. Overcurrent protecting characteristics

No	Rated current of release(A)	Initial state	Test current	Specified time	Result to be obtained	Remarks
1	1-63	cold state	1.13I _n	$t \leq 1$ h	Non-trip	
2	1-63	upon the previous test	1.45I _n	$t < 1$ h	trip	Setting current up to specified value steadily in 5S
3	I _n ≤ 32	cold state	2.55I _n	1s < t < 60s	trip	
	I _n > 32	cold state	2.55I _n	1s < t < 120s	trip	
4	1-63	cold state	3I _n	$t \leq 0.1$ s	Non-trip	B type
	1-63	cold state	5I _n	$t < 1.1$ s	trip	B type
	1-63	cold state	5I _n	$t \leq 0.1$ s	Non-trip	C type
	1-63	cold state	10I _n	$t < 1.1$ s	trip	C type
	1-63	cold state	10I _n	$t \leq 0.1$ s	Non-trip	D type
	1-63	cold state	20I _n	$t < 1.1$ s	trip	D type

3. Endurance(operations)

Category	Operations	Operation frequency	Rated current
Electrical endurance	8000	240/h	0.5-32
		120/h	40-63
Mechanical endurance	20000	240/h	0.5-63

4.Features

Much higher short circuit breaking capacity, Dual-connection convenient for both standard busbar and conductor connection. Improved safety of operators offered by special design from terminals. Much longer service life thanks to energy-storage operating mechanism. Enclosure and functional parts made from imported plastics with flame-retardant, heat-resistant, and impulse-proof properties. Higher current-limiting capacity ensuring a cost-effective range of products. Different handle color for different rated current with contactor condition indicator.

5. Overall and mounting dimensions

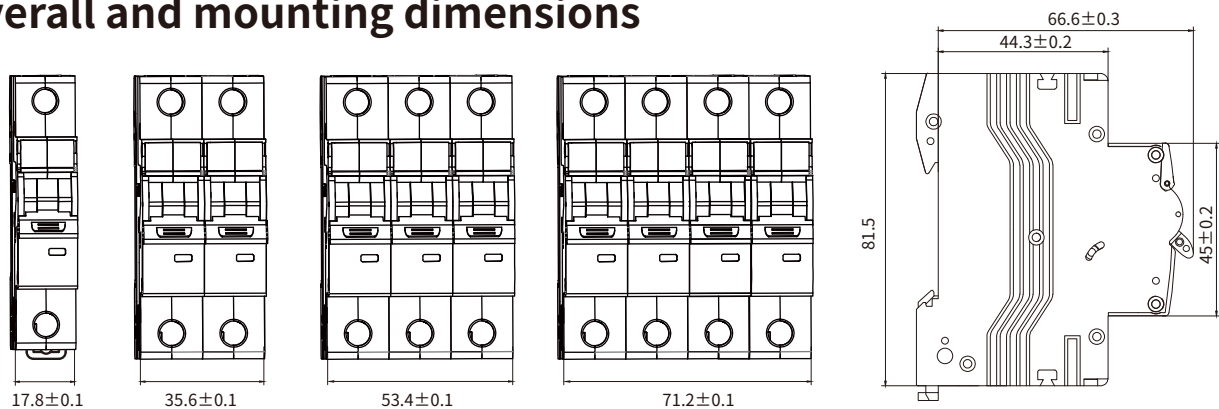

MGB-63M/MGB-63H

MGB-63M-DC Series

Miniature Circuit Breaker

Technical data

Standard	EN/IEC60947-2
Breaking capacity	6kA
Protection	Against overload and short circuit
Rated current In	1,2,3,4,6,10,13,16,20,25,32,40,50,63A
Rated voltage	DC: Rated voltage Ue(VDC): 1P 250 3P 750 2P 500 4P 1000 Operational volatge(VDC): Min.:12 Max :1P 250 2P 500
Ambient temperature (°C)	-5~+40
Characteristic	Thermal operating limit: (1.05-1.30) x In Magnetic operating: (8-12) x In
Number of poles	1P,2P,3P and 4P
Type of trip	Thermal/magnetic release
Type of terminal	Lug type and Pin type
Terminal capacity	16mm ² flexible or 25mm ² rigid up to 25A ratings 25mm ² flexible or 35mm ² rigid from 32A to 63A ratings
Protection degree	IP20
Installation	Mounting on 35mm DIN rail
Width	17.8mm per pole



MGB-63M-DC-1P



MGB-63M-DC-2P



MGB-63M-DC-3P



MGB-63M-DC-4P

MGB-63M-DC MCB



MGB-63M-DC-1P



MGB-63M-DC-2P

Rated current(A)	DC type	Packing unit
1	MGB-63M/1-DC1	12
2	MGB-63M/1-DC2	12
3	MGB-63M/1-DC3	12
4	MGB-63M/1-DC4	12
6	MGB-63M/1-DC6	12
10	MGB-63M/1-DC10	12
13	MGB-63M/1-DC13	12
16	MGB-63M/1-DC16	12
20	MGB-63M/1-DC20	12
25	MGB-63M/1-DC25	12
32	MGB-63M/1-DC32	12
40	MGB-63M/1-DC40	12
50	MGB-63M/1-DC50	12
63	MGB-63M/1-DC63	12
<hr style="border-top: 1px dashed black;"/>		
1	MGB-63M/2-DC1	6
2	MGB-63M/2-DC2	6
3	MGB-63M/2-DC3	6
4	MGB-63M/2-DC4	6
6	MGB-63M/2-DC6	6
10	MGB-63M/2-DC10	6
13	MGB-63M/2-DC13	6
16	MGB-63M/2-DC16	6
20	MGB-63M/2-DC20	6
25	MGB-63M/2-DC25	6
32	MGB-63M/2-DC32	6
40	MGB-63M/2-DC40	6
50	MGB-63M/2-DC50	6
63	MGB-63M/2-DC63	6

MGB-63M-DC MCB



MGB-63M-DC-3P



MGB-63M-DC-4P

Rated current(A)	DC type	Packing unit
1	MGB-63M/3-DC1	4
2	MGB-63M/3-DC2	4
3	MGB-63M/3-DC3	4
4	MGB-63M/3-DC4	4
6	MGB-63M/3-DC6	4
10	MGB-63M/3-DC10	4
13	MGB-63M/3-DC13	4
16	MGB-63M/3-DC16	4
20	MGB-63M/3-DC20	4
25	MGB-63M/3-DC25	4
32	MGB-63M/3-DC32	4
40	MGB-63M/3-DC40	4
50	MGB-63M/3-DC50	4
63	MGB-63M/3-DC63	4

1	MGB-63M/4-DC1	3
2	MGB-63M/4-DC2	3
3	MGB-63M/4-DC3	3
4	MGB-63M/4-DC4	3
6	MGB-63M/4-DC6	3
10	MGB-63M/4-DC10	3
13	MGB-63M/4-DC13	3
16	MGB-63M/4-DC16	3
20	MGB-63M/4-DC20	3
25	MGB-63M/4-DC25	3
32	MGB-63M/4-DC32	3
40	MGB-63M/4-DC40	3
50	MGB-63M/4-DC50	3
63	MGB-63M/4-DC63	3

1. Overcurrent protecting characteristics

No	Rated current of release(A)	Initial state	Test current	Specified time	Result to be obtained	Remarks
1	1-63	cold state	1.05In	$t \leq 1$ h	Non-trip	
2	1-63	upon the previous test	1.30In	$t < 1$ h	trip	Setting current up to specified value steadily in 5S
3	$I_n \leq 32$	cold state	2.55In	$1s < t < 60s$	trip	
	$I_n > 32$	cold state	2.55In	$1s < t < 120s$	trip	
4	1-63	cold state	8In	$t \leq 0.1s$	Non-trip	C type
	1-63	cold state	12In	$t < 1.1s$	trip	C type

2. Endurance(operations)

Category	Operations	Operation frequency	Rated current
Electrical endurance	4000	240/h	0.5-32
		120/h	40-63
Mechanical endurance	10000	240/h	0.5-63

3.Features

Much higher short circuit breaking capacity, Dual-connection convenient for both standard busbar and conductor connection. Improved safety of operators offered by special design from terminals. Much longer service life thanks to energy-storage operating mechanism. Enclosure and functional parts made from imported plastics with flame-retardant, heat-resistant, and impulse-proof properties. Higher current-limiting capacity ensuring a cost-effective range of products. Different handle color for different rated current with contactor condition indicator.

4. Overall and mounting dimensions

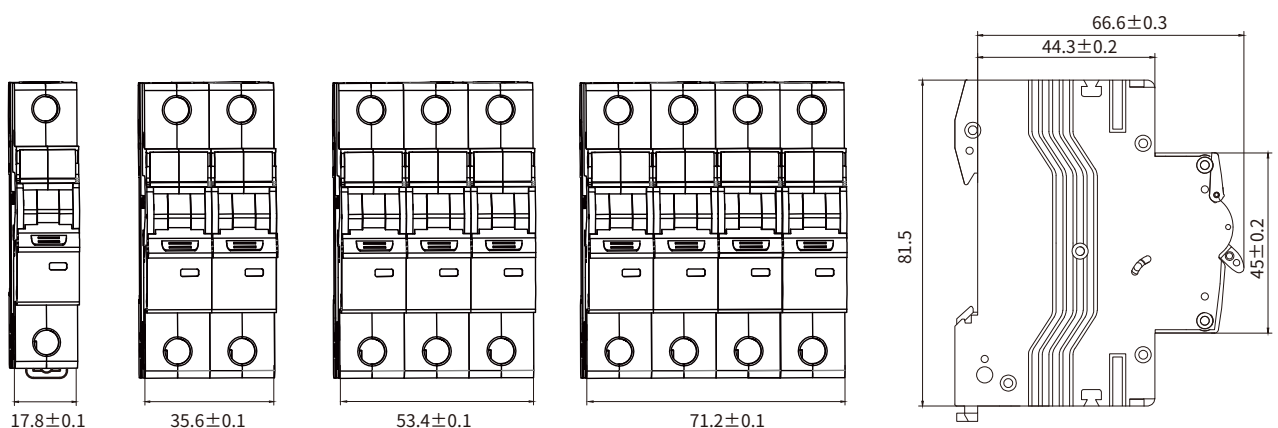

MGB-63M-DC

EP-DPN Series “Phase+Neutral” Circuit Breaker

Technical data

Standard	EN/ IEC60898-1
Breaking capacity	3kA, 4.5kA, 6kA
Protection	Overload and short circuit
Rated insulation voltage U_i	500V
Rated impulse withstand voltage U_{imp}	4kV
Rated current I_n	2, 4, 6, 10, 13, 16, 20, 25, 32A
Rated voltage	240VAC
Characteristic	B, C Curve
Number of poles	1P+N
Type of trip	Thermal / magnetic release
Type of terminal	Pin type
Terminal capacity	1-10mm ² wire
Protection degree	IP20
Installation	Mounting on 35mm DIN rail
Width	17.8mm per pole
Electrical endurance	4000
Mechanical endurance	10000
Altitude	≤2000m
Relative humidity	+20°C, ≤95%, ±40°C, ≤50%



EP-DPN3K



EP-DPN4.5K



EP-DPN6K

EP-DPN MCB



EP-DPN3K



EP-DPN4.5K



EP-DPN6K

Rated current(A)	B curve	C curve	Packing unit
2	EP-DPN3K-B2	EP-DPN3K-C2	12
4	EP-DPN3K-B4	EP-DPN3K-C4	12
6	EP-DPN3K-B6	EP-DPN3K-C6	12
10	EP-DPN3K-B10	EP-DPN3K-C10	12
13	EP-DPN3K-B13	EP-DPN3K-C13	12
16	EP-DPN3K-B16	EP-DPN3K-C16	12
20	EP-DPN3K-B20	EP-DPN3K-C20	12
25	EP-DPN3K-B25	EP-DPN3K-C25	12
32	EP-DPN3K-B32	EP-DPN3K-C32	12

2	EP-DPN4.5K-B2	EP-DPN4.5K-C2	12
4	EP-DPN4.5K-B4	EP-DPN4.5K-C4	12
6	EP-DPN4.5K-B6	EP-DPN4.5K-C6	12
10	EP-DPN4.5K-B10	EP-DPN4.5K-C10	12
13	EP-DPN4.5K-B13	EP-DPN4.5K-C13	12
16	EP-DPN4.5K-B16	EP-DPN4.5K-C16	12
20	EP-DPN4.5K-B20	EP-DPN4.5K-C20	12
25	EP-DPN4.5K-B25	EP-DPN4.5K-C25	12
32	EP-DPN4.5K-B32	EP-DPN4.5K-C32	12

2	EP-DPN6K-B2	EP-DPN6K-C2	12
4	EP-DPN6K-B4	EP-DPN6K-C4	12
6	EP-DPN6K-B6	EP-DPN6K-C6	12
10	EP-DPN6K-B10	EP-DPN6K-C10	12
13	EP-DPN6K-B13	EP-DPN6K-C13	12
16	EP-DPN6K-B16	EP-DPN6K-C16	12
20	EP-DPN6K-B20	EP-DPN6K-C20	12
25	EP-DPN6K-B25	EP-DPN6K-C25	12
32	EP-DPN6K-B32	EP-DPN6K-C32	12

1. Curves

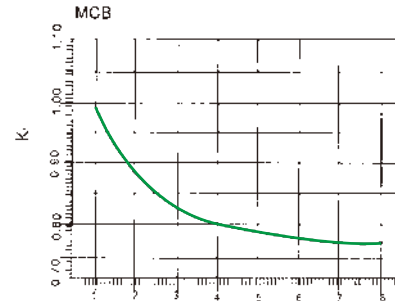
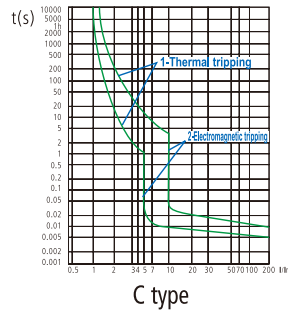
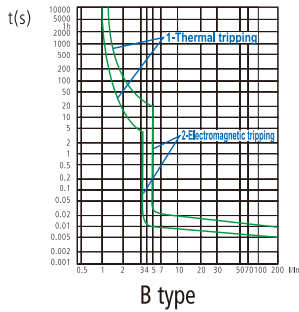

2. Please refer to table below for temperature compensation correction

Rated current (A)	Temperature compensation coefficient under various operational temperature							
	-10°C	0°C	10°C	20°C	30°C	40°C	50°C	60°C
1	1.17	1.13	1.09	1.04	1	0.96	0.91	0.84
2	1.17	1.13	1.09	1.04	2	0.96	0.91	0.84
4	1.17	1.13	1.09	1.04	4	0.96	0.91	0.84
6	1.17	1.13	1.09	1.04	6	0.96	0.91	0.84
10	1.21	1.16	1.09	1.04	10	0.94	0.88	0.82
16	1.18	1.13	1.09	1.04	16	0.94	0.91	0.84
20	1.17	1.13	1.09	1.04	20	0.96	0.91	0.84
25	1.18	1.13	1.09	1.04	25	0.96	0.91	0.84
32	1.17	1.13	1.09	1.04	32	0.96	0.91	0.84

3. Wiring

The suitable conductors should be used for connection, see table below for relative parameters.

Rated current In (A)	Nominal cross section area s(mm ²)	Tightening torque (N.m)
≤6	1	1.2
10	1.5	1.2
16~20	2.5	1.2
25	4	1.2
32	6	1.2

4. Features

- Compact design and cost-effective;
- Enclosure and functional parts made from imported plastics with flame-retardant, heat-resistant, and impulse-proof properties; Potential electric shock is avoided thanks to neutral-line being directly connected to the product;
- Convenient and time-saving mounting

5. Overall and mounting dimensions

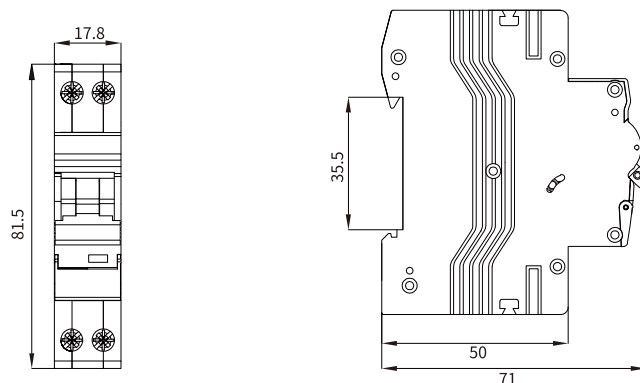

EP-DPN



EPB-125H Series Miniature Circuit Breaker

Technical data

Standard	EN/ IEC60898-1, EN/ IEC60947-2	
Breaking capacity	6kA	10kA
Protection	Against overload and short circuit	
Rated current I_n	40, 50, 63,80, 100, 125A	
Rated voltage	1 pole 240V AC 50/60Hz 2,3,4pole 415V AC 50/60Hz	
Characteristic		IEC60898-1 IEC60947-2
	Thermal operating limit:	(1.13-1.45)xI _n (1.05-1.30)xI _n
	Magnetic operating:	B: (3-5)xI _n (8-12)xI _n C: (5-10)xI _n D: (10-20)xI _n
Number of poles	1P,2P,3P,4P	
Type of trip	Thermal / magnetic release	
Type of terminal	Pin type	
Terminal capacity	Flexible cables: 1.5 to 35mm ² Rigid cables: 1 to 50mm ²	
Installation	Mounting on 35mm DIN rail	
Width	27mm per pole	



EPB-125H

Rated current(A)	IEC60898-1			IEC60947-2	Packing unit	
	B curve	C curve	D curve			
 <p>1P</p>	40	EPB-125H/1-B40	EPB-125H/1-C40	EPB-125H/1-D40	EPB-125H/1-40	12
	50	EPB-125H/1-B50	EPB-125H/1-C50	EPB-125H/1-D50	EPB-125H/1-50	12
	63	EPB-125H/1-B63	EPB-125H/1-C63	EPB-125H/1-D63	EPB-125H/1-63	12
	80	EPB-125H/1-B80	EPB-125H/1-C80	EPB-125H/1-D80	EPB-125H/1-80	12
	100	EPB-125H/1-B100	EPB-125H/1-C100	EPB-125H/1-D100	EPB-125H/1-100	12
	125	EPB-125H/1-B125	EPB-125H/1-C125	EPB-125H/1-D125	EPB-125H/1-125	12
 <p>2P</p>	40	EPB-125H/2-B40	EPB-125H/2-C40	EPB-125H/2-D40	EPB-125H/2-40	6
	50	EPB-125H/2-B50	EPB-125H/2-C50	EPB-125H/2-D50	EPB-125H/2-50	6
	63	EPB-125H/2-B63	EPB-125H/2-C63	EPB-125H/2-D63	EPB-125H/2-63	6
	80	EPB-125H/2-B80	EPB-125H/2-C80	EPB-125H/2-D80	EPB-125H/2-80	6
	100	EPB-125H/2-B100	EPB-125H/2-C100	EPB-125H/2-D100	EPB-125H/2-100	6
	125	EPB-125H/2-B125	EPB-125H/2-C125	EPB-125H/2-D125	EPB-125H/2-125	6
 <p>3P</p>	40	EPB-125H/3-B40	EPB-125H/3-C40	EPB-125H/3-D40	EPB-125H/3-40	4
	50	EPB-125H/3-B50	EPB-125H/3-C50	EPB-125H/3-D50	EPB-125H/3-50	4
	63	EPB-125H/3-B63	EPB-125H/3-C63	EPB-125H/3-D63	EPB-125H/3-63	4
	80	EPB-125H/3-B80	EPB-125H/3-C80	EPB-125H/3-D80	EPB-125H/3-80	4
	100	EPB-125H/3-B100	EPB-125H/3-C100	EPB-125H/3-D100	EPB-125H/3-100	4
	125	EPB-125H/3-B125	EPB-125H/3-C125	EPB-125H/3-D125	EPB-125H/3-125	4
 <p>4P</p>	40	EPB-125H/4-B40	EPB-125H/4-C40	EPB-125H/4-D40	EPB-125H/4-40	3
	50	EPB-125H/4-B50	EPB-125H/4-C50	EPB-125H/4-D50	EPB-125H/4-50	3
	63	EPB-125H/4-B63	EPB-125H/4-C63	EPB-125H/4-D63	EPB-125H/4-63	3
	80	EPB-125H/4-B80	EPB-125H/4-C80	EPB-125H/4-D80	EPB-125H/4-80	3
	100	EPB-125H/4-B100	EPB-125H/4-C100	EPB-125H/4-D100	EPB-125H/4-100	3
	125	EPB-125H/4-B125	EPB-125H/4-C125	EPB-125H/4-D125	EPB-125H/4-125	3

EPB-125H MCB

1. Curves

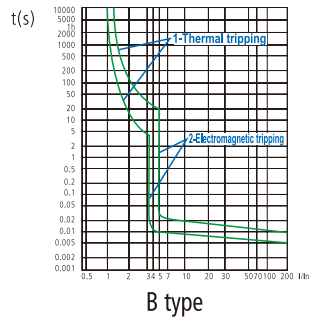
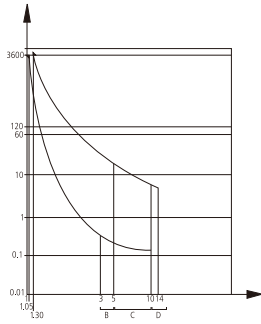

B type

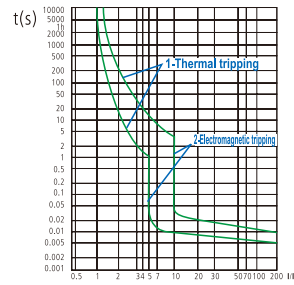

C type

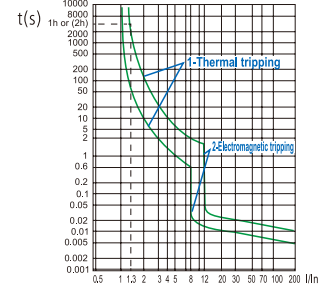

D type

2. Breaking capacity

Type	Voltage	Breaking capacity I _{cn} (A)	Standard
1P	230/240	10000	IEC60947-2
2P,3P,4P	230/240	10000	
	400/415	10000	

3. Wiring

The suitable conductors should be used for connection, see table below for relative parameters.

Rated current I _n (A)	Nominal cross section area s (mm ²)	Tightening torque (N.m)
63	16	3.5
80	25	3.5
100	35	3.5
125	50	3.5

4. Features

1. High rated short-circuit breaking capacity up to 10000A on IEC60947-2 / IEC60898-1 standard.
2. Service life of product has been greatly enhanced through special designed tripping mechanism.
3. Long-time and reliable operation.
4. Enclosure and functional parts made from imported plastics with flame-retardant, heat-resistant, and impulse-proof properties.
5. Compact and modularized design.
6. Convenient mounting.
7. A wide range of RCD and RCBO.
8. Full sets of additional components and full sets of accessories.

5. Overall and mounting dimensions

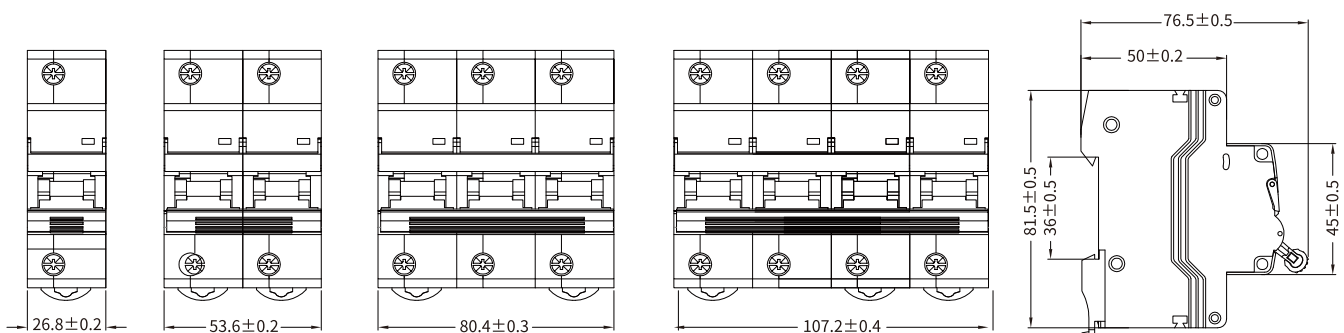

EPB-125H

MGI-R Series Isolating Switch

Technical data

Standard	EN/IEC60947-3
Number of poles	1P,2P,3P,4P
Rated currents	16,20,25,32,40,50,63,80,100A
Rated voltage	1pole 240VAC 50/60Hz 2,3,4Pole 415VAC 50/60Hz
Utilization category	AC-22A
I _{cw}	12I _e , t= 1 s
Rated short-circuit making capacity I _{cm}	20I _e
Rated making & breaking capacity	3I _e , 1.05U _e , COSφ=0.65
Rated insulation voltage U _i	690V
Rated impulse withstand voltage U _{imp}	6KV
Electrical endurance	1500
Mechanical endurance	10000
Type of terminal	Lug type and Pin type
Terminal capacity	Cables up to 50mm ²
Ambient temperature (°C)	-5~+35, Max.95% humidity
Storage temperature(°C)	-40~+75
Altitude (meters)	Max. 2,000
Protection degree	IP20
Installation	Mounting on 35mm DIN rail
Width	17.8mm per pole



MGI-R-1P



MGI-R-2P



MGI-R-3P



MGI-R-4P

MGI-R Isolating Switch



MGI-R-1P



MGI-R-2P



MGI-R-3P



MGI-R-4P

Pole	In	Model	Packing unit
1P	16A	MGI-R-16/1	12
1P	20A	MGI-R-20/1	12
1P	25A	MGI-R-25/1	12
1P	32A	MGI-R-32/1	12
1P	40A	MGI-R-40/1	12
1P	50A	MGI-R-50/1	12
1P	63A	MGI-R-63/1	12
1P	80A	MGI-R-80/1	12
1P	100A	MGI-R-100/1	12

2P	16A	MGI-R-16/2	6
2P	20A	MGI-R-20/2	6
2P	25A	MGI-R-25/2	6
2P	32A	MGI-R-32/2	6
2P	40A	MGI-R-40/2	6
2P	50A	MGI-R-50/2	6
2P	63A	MGI-R-63/2	6
2P	80A	MGI-R-80/2	6
2P	100A	MGI-R-100/2	6

3P	16A	MGI-R-16/3	4
3P	20A	MGI-R-20/3	4
3P	25A	MGI-R-25/3	4
3P	32A	MGI-R-32/3	4
3P	40A	MGI-R-40/3	4
3P	50A	MGI-R-50/3	4
3P	63A	MGI-R-63/3	4
3P	80A	MGI-R-80/3	4
3P	100A	MGI-R-100/3	4

4P	16A	MGI-R-16/4	3
4P	20A	MGI-R-20/4	3
4P	25A	MGI-R-25/4	3
4P	32A	MGI-R-32/4	3
4P	40A	MGI-R-40/4	3
4P	50A	MGI-R-50/4	3
4P	63A	MGI-R-63/4	3
4P	80A	MGI-R-80/4	3
4P	100A	MGI-R-100/4	3

1. Endurance(operations)

Category	Operations	Operation frequency	Rated current
Electric endurance	1500	120/h	16~100A
Mechanical endurance	10000	120/h	16~100A

2. Wiring

The suitable conductors should be used for connection, see table below for relative parameters.

Rated current In (A)	Cross section area s (mm ²)	Tightening torque (N.m)
16	2.5	3.5
20	2.5	3.5
25	4	3.5
32	6	3.5
40	10	3.5
50	10	3.5
63	16	3.5
80	35	3.5
100	35	3.5

3. Features

1. Current capacity is enhanced and electric drive compensation is fully applied
2. Reliable operation thanks to special designed operating mechanism
3. Safe operation is ensured

4. Overall and mountina dimensions

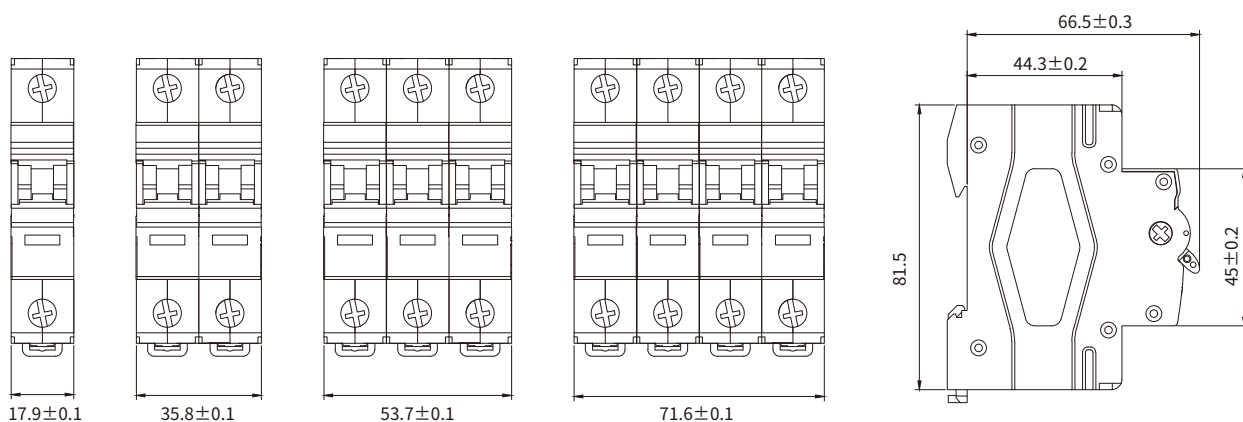

MGI-R

EPBA Series

Circuit Breaker Accessories

Technical data

Standard	EN/ IEC 62019
Rated insulation voltage Ui	500V
Rated voltage	AC 230V
Rated frequency(Hz)	50/60Hz
Utilization catagory	AC14,AC15
Ambient temperature(°C)	-5~+40, max 95%humidity
Storage temprature (°C)	-40~+75
Electric endurance	4000
Mechanical endurance	10000
Dielectric strength	2000V/1min
Protection degree	IP20



EPBA-OF

EPBA-SD

EPBA-MN

EPBA-MX

EPB-63M-1P

Application

Applicable to MCB model EPB-63, used to control remote signaling device.



Combination scheme

OF	EPB-63	OF	MX	EPB-63
----	--------	----	----	--------

OF Auxiliary Contact

Type code	Rated voltage (V)	Rated current (A)
OF23A	230AC	6
OF40A	400AC	3
OF24D	24 DC	6
OF48D	48 DC	2



OF

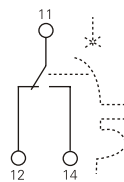

Dielectric strength: 2kV/1 min

Electro-mechanical endurance: ≥ 5000

Mounted on the left side of the MCB EPB-63, indicating "ON", "OFF" status of combined MCB.

Terminal Connection Height: H1 = 31 mm H2 = 16 mm H3 = 1.3 mm

MX Shunt Tripper

Type code	Rated voltage (V)
MX23A	230AC
MX40A	400AC
MX24D	24 DC
MX48D	48 DC



MX

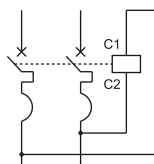

Rated insulation voltage(U_i): 500V

Operate voltage range: 70-100% U_s

Contact capacity: AC:3A/400V, AC:6A/230V, AC:9A/125V

Dielectric strength: 2kV/1 min

Electro-mechanical endurance: ≥ 4000

Mounting on the left side of MCB/RCBO, used to trip the combined MCB/RCBO by remote controlling device.

Terminal Connection Height: 19mm

Application

Applicable to MCB model EPB-63, used to control remote signaling device.



Combination scheme

SD	EPB-63	SD	MN	EPB-63
----	--------	----	----	--------

SD Alarm Switch

Type code	Rated voltage (V)	Rated current (A)
SD23A	230AC	6
SD40A	400AC	3
SD24D	24 DC	6
SD48D	48 DC	2



SD

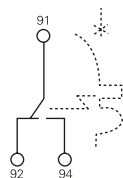

Rated insulation voltage (U_i): 500V

Dielectric strength: 2KV/1 min

Electro-mechanical endurance: ≥ 4000

Is used to connect ON/OFF auxiliary contact, work as circuit breaker ON/OFF indicator in case of faulty (tripping)



MN

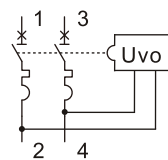

MN Over-voltage/Under-voltage Tripper

Type code	Rated voltage (V)
MN23A	230AC

Rated insulation voltage (U_i): 500V

Over-voltage tripping range: 280V ± 5%

Under-voltage tripping range: 170V ± 5%

Electro-mechanical endurance: ≥ 4000

Mounted on the left side of circuit breaker, actuate the combined device to trip in case of under-voltage or over-voltage, effectively prevent the device from closing operation under abnormal power voltage condition.

Technical data



UVT

Code No.	UVT
Current	25A, 40A, 63A
Dimension	Poles: 2P 4P Size: 58mm 90mm
Voltage range	2P: 230VAC, 4P: 415VAC
Function range	2P: 280VAC, 4P: 480VAC

Wire diagram

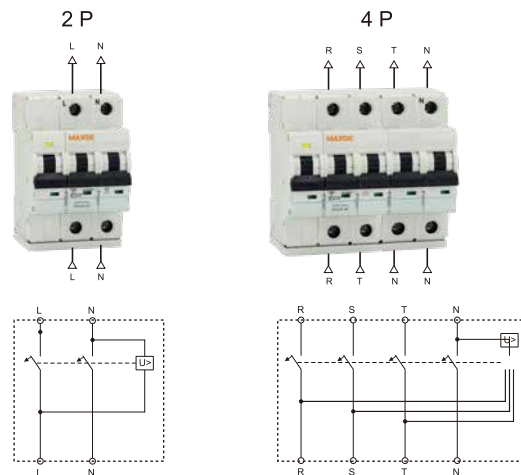

Technical data



UVT + SPD

Code No.	UVT+SPD
Current	25A, 32, 40A, 63A
Dimension	Poles: 2P 4P Size: 58mm 108mm
Capacity	Type 2 - 15kA max
Voltage range	2P: 230VAC, 4P: 415VAC
Function range	2P: 280VAC, 4P: 480VAC

Wire diagram

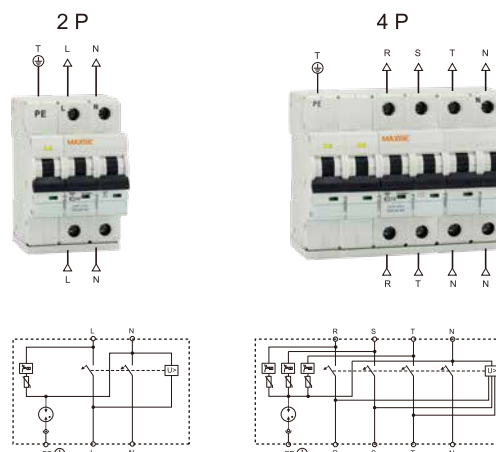

1. Benefits

- 1.Brand
2. Type
3. Rated current
4. Tripping type
5. Rated voltage
6. Breaking capacity
7. Energy Limiting
8. Approval
9. Electrical wiring diagram
10. ON/OFF indication

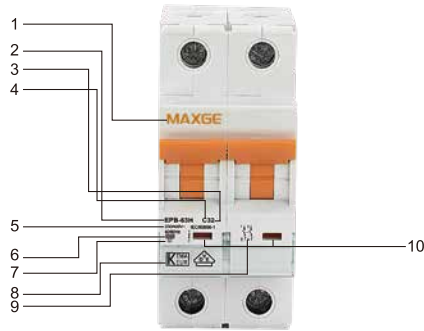

- ◆ Attractive device design
- ◆ Easily recognized, color-coded switching position
- ◆ Indication integrated in the handle.

- ◆ Well matched with RCCB EPR-2



- ◆ Well matched with Isolator EPI-R

- ◆ Auxiliary contacts can be added on the left side of the MCB

- ◆ Ergonomic handle for user-friendly switching



- ◆ Safety terminal:
 - easy wiring
 - protection degree IP20.
- ◆ Pozidriv and slot screw head. Torque up to 4 N.m.

- ◆ MCB and RCCB can be connected with PIN type busbar both at the top and bottom terminals.with easy DIN-rail extraction.

- ◆ MCB and RCCB can be connected with FORK type busbar both at the top and bottom terminals.with easy DIN-rail extraction.

EPC1 Series Modular Contactor

Technical data

Standard	EN/IEC 61095
Maximum power	AC1 220/230VAC: 20A 4.5KW(EPC1-20) 25A 16KW(EPC1-25) AC-1/AC-7a 380/400VAC: 63A 40KW(EPC1-63) AC-3/AC-7b 380/400VAC: 25A 15KW(EPC1-63) 4KW(EPC1-25)
Main contacts terminal capacity	1.5-6mm ² (EPC1-10/16/20/25A) 6-35mm ² (EPC1-40/63A)
Coil contact A1, A2 terminal capacity	0.75-2.5mm ²
Electric endurance	≥100,000
Mechanical endurance	≥5000,000
Protection degree	IP20
Terminal tightening torque(N.m)	0.8-3.5
Ambient temperature (°C)	-5~+60, max. 95%humidity
Storage temperature(°C)	-40~+75
Connection capacity(mm²)	1-25



EPC1-2P(10A-25A)



EPC1-2P(32A-63A)



EPC1-4P(10A-25A)



EPC1-4P(32A-63A)

EPC1 Modular Contactor



EPC1-2P(10A-25A)



EPC1-4P(10A-25A)

Code No.	Rated current In(A)		Contact position	Control voltage (Vac)	Rated control power in(KW)	
	Ac-7a/Ac-1	Ac-7b/Ac-1			Ac-7a/230V	Ac-7b/230V
EPC1-10-11	10	4	1NO+1NC	240	2	0.75
EPC1-10-20	10	4	2NO	240	2	0.75
EPC1-10-02	10	4	2NC	240	2	0.75
EPC1-16-11	16	6	1NO+1NC	240	3.2	1.0
EPC1-16-20	16	6	2NO	240	3.2	1.0
EPC1-16-02	16	6	2NC	240	3.2	1.0
EPC1-20-11	20	7	1NO+1NC	240	4	1.2
EPC1-20-20	20	7	2NO	240	4	1.2
EPC1-20-02	20	7	2NC	240	4	1.2
EPC1-25-11	25	9	1NO+1NC	240	5	1.4
EPC1-25-20	25	9	2NO	240	5	1.4
EPC1-25-02	25	9	2NC	240	5	1.4
EPC1-10-22	10	4	2NO+2NC	240	6.2	2.2
EPC1-10-31	10	4	3NO+1NC	240	6.2	2.2
EPC1-10-40	10	4	4NO	240	6.2	2.2
EPC1-10-04	10	4	4NC	240	6.2	2.2
EPC1-16-22	16	6	2NO+2NC	240	10	3
EPC1-16-31	16	6	3NO+1NC	240	10	3
EPC1-16-40	16	6	4NO	240	10	3
EPC1-16-04	16	6	4NC	240	10	3
EPC1-20-22	20	7	2NO+2NC	240	13	3.5
EPC1-20-31	20	7	3NO+1NC	240	13	3.5
EPC1-20-40	20	7	4NO	240	13	3.5
EPC1-20-04	20	7	4NC	240	13	3.5
EPC1-25-22	25	9	2NO+2NC	240	15	4
EPC1-25-31	25	9	3NO+1NC	240	15	4
EPC1-25-40	25	9	4NO	240	15	4
EPC1-25-04	25	9	4NC	240	15	4

Overall and mounting dimensions

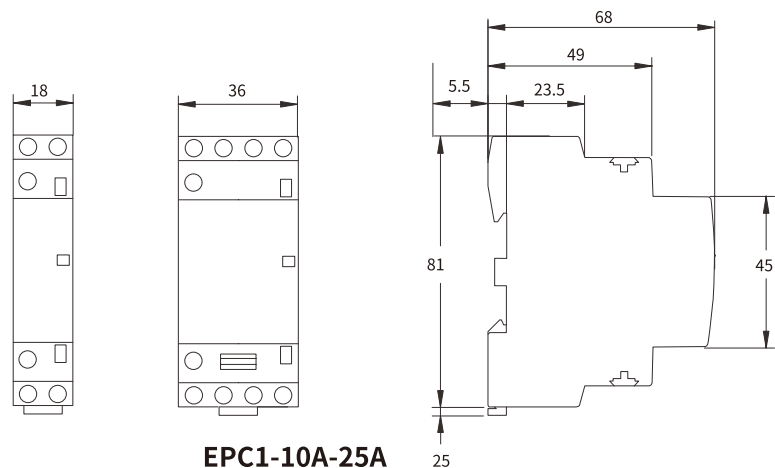

EPC1 Modular Contactor



EPC1-2P(32A-63A)



EPC1-4P(32A-63A)

Code No.	Rated current In(A)		Contact position	Control voltage (Vac)	Rated control power in(KW)	
	Ac-7a/Ac-1	Ac-7b/Ac-1			Ac-7a/400V	Ac-7b/400V
EPC1-32-11	32	12	1NO+1NC	240	6.5	2
EPC1-32-20	32	12	2NO	240	6.5	2
EPC1-32-02	32	12	2NC	240	6.5	2
EPC1-40-11	40	15	1NO+1NC	240	8.5	2.5
EPC1-40-20	40	15	2NO	240	8.5	2.5
EPC1-40-02	40	15	2NC	240	8.5	2.5
EPC1-63-11	63	25	1NO+1NC	240	13	4
EPC1-63-20	63	25	2NO	240	13	4
EPC1-63-02	63	25	2NC	240	13	4
EPC1-32-22	32	12	2NO+2NC	240	21	6.5
EPC1-32-31	32	12	3NO+1NC	240	21	6.5
EPC1-32-40	32	12	4NO	240	21	6.5
EPC1-32-04	32	12	4NC	240	21	6.5
EPC1-40-22	40	15	2NO+2NC	240	26	7.5
EPC1-40-31	40	15	3NO+1NC	240	26	7.5
EPC1-40-40	40	15	4NO	240	26	7.5
EPC1-40-04	40	15	4NC	240	26	7.5
EPC1-63-22	63	25	2NO+2NC	240	40	13
EPC1-63-31	63	25	3NO+1NC	240	40	13
EPC1-63-40	63	25	4NO	240	40	13
EPC1-63-04	63	25	4NC	240	40	13

Overall and mounting dimensions

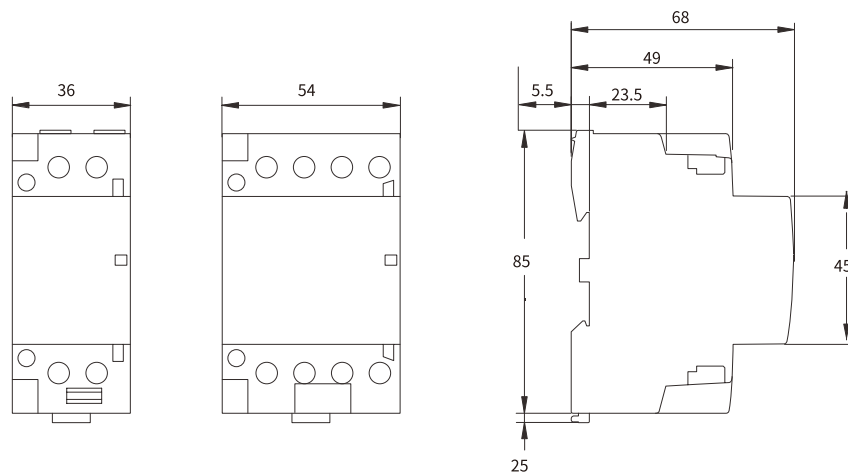

EPC1-32A-63A

Refer to other coil voltage listed as followings:

Coil voltage(V)	24	36	48	110	127	220	230	240	380	415	440	480	500	600	660
50Hz	B5	C5	E5	F5	G5	M5	P5	U5	Q5	N5	R5	T5	S5	-	Y5
60Hz	B6	-	E6	F6	G6	M6	P6	U6	Q6	N6	R6	T6	-	S6	-
50/60Hz	B7	C7	E7	F7	G7	M7	P7	U7	Q7	N7	R7	T7	-	-	-

EPSO Series Door Bell

Technical data

Standard	EN / IEC 61558-1
Electric ratings	8V, 12V, 24V, 110V,230V,50/60Hz
Installation class	II&III
Pollution grade	II
Working condition	Short-time working
Degree of protection	IP20
Mounting	35mm DIN rail

EPTF-8 Series Transformer

Technical data

Standard	EN/IEC61558
Input voltage	230VAC 50/60Hz
Output voltage	4,6,8,12,16,24V
Rated power output	8VA
Consumption	1.15W
Pollution class	I
Mounting	35mm DIN rail
Service period	Continuous operating
Connection terminals	Pillar terminal with clamp
Connection capacity	Rigid conductor 10mm ²
Terminal Connection Height	H=15.5mm
Installation	On symmetrical DIN rail Panel mounting



EPSO



EPTF-8

EPISO Door Bell	Operational voltage(V)	Code No.	Capacity (VA)	Noise level	Packing unit
	8V	EPISO-8V	4.8 VA	78dB	12
	12V	EPISO-12V	4.8 VA	78dB	12
	24V	EPISO-24V	4.8 VA	78dB	12
	110V	EPISO-110V	4.4 VA	78dB	12
	230V	EPISO-230V	4.0 VA	78dB	12



EPISO

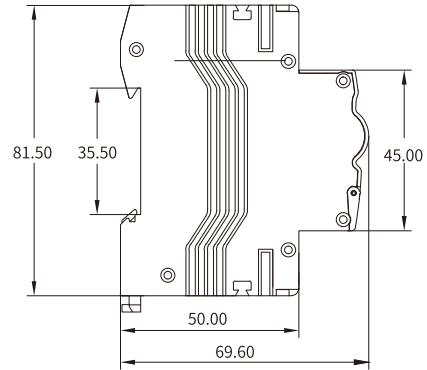

EPTF-8 Transformer	Rated output power P2(VA)	Code No.	Rated voltage		Current w/o Load I ₀ (A)	Power consumption w/o Load P ₀ (W)	Coil Temperature rising(°C)
			Primary U1(V)	Secondary U2(U)			
	8	EPTF-8-4	230(240)	4	36±6	1.15	50
		EPTF-8-6		6			
		EPTF-8-8		8			
		EPTF-8-12		12			
		EPTF-8-16		16			
		EPTF-8-24		24			



EPTF-8

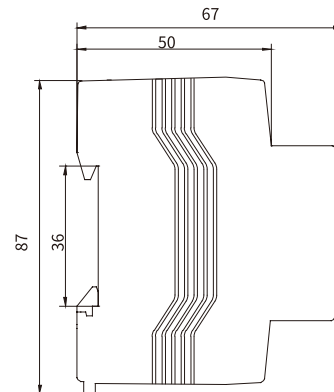
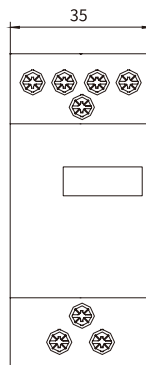

EPTF-8

EPSL-1 Series

Indicating Light

Technical data

Standard	EN/IEC60947-5-1
Rated current AC12	20A
Electric ratings	Up to 230VAC 50/60Hz
Rated insulation Voltage Ui	500V
Illumination	LED, Incandescence, neon
Life	Incandescence lamp $\geq 1000h$ Neon lamp $\geq 2000h$ LED $\geq 30000h$
Ambient temperature(°C)	-5~+40,max.95% humidity
Storage temperature(°C)	-40~+75
Connection capacity(mm²)	1-16
Color	Green,red,yellow,blue,white
Type of terminal	Pin type and Lug type
Protection degree	IP20
Mounting	35mm DIN rail



EPSL-1 Red

EPSL-1 Yellow

EPSL-1 Green

EPSL-1 Indicating Light



EPSL-1 Red



EPSL-1 Yellow



EPSL-1 Green

Operational voltage(V)	Code	Illumination	Color	Packing unit
6.3V AC/DC	EPSL-1-G-L6	Neon Incandescence LED	Green ■	12
12V AC/DC	EPSL-1-G-L12	Neon Incandescence LED	Green ■	12
24V AC/DC	EPSL-1-G-L24	Neon Incandescence LED	Green ■	12
110V AC/DC	EPSL-1-G-L110	Neon Incandescence LED	Green ■	12
230V AC/DC	EPSL-1-G-L230	Neon Incandescence LED	Green ■	12
6.3V AC/DC	EPSL-1-R-L6	Neon Incandescence LED	Red ■	12
12V AC/DC	EPSL-1-R-L12	Neon Incandescence LED	Red ■	12
24V AC/DC	EPSL-1-R-L24	Neon Incandescence LED	Red ■	12
110V AC/DC	EPSL-1-R-L110	Neon Incandescence LED	Red ■	12
230V AC/DC	EPSL-1-R-L230	Neon Incandescence LED	Red ■	12
6.3V AC/DC	EPSL-1-Y-L6	Neon Incandescence LED	Yellow ■	12
12V AC/DC	EPSL-1-Y-L12	Neon Incandescence LED	Yellow ■	12
24V AC/DC	EPSL-1-Y-L24	Neon Incandescence LED	Yellow ■	12
110V AC/DC	EPSL-1-Y-L110	Neon Incandescence LED	Yellow ■	12
230V AC/DC	EPSL-1-Y-L230	Neon Incandescence LED	Yellow ■	12
6.3V AC/DC	EPSL-1-B-L6	Neon Incandescence LED	Blue ■	12
12V AC/DC	EPSL-1-B-L12	Neon Incandescence LED	Blue ■	12
24V AC/DC	EPSL-1-B-L24	Neon Incandescence LED	Blue ■	12
110V AC/DC	EPSL-1-B-L110	Neon Incandescence LED	Blue ■	12
230V AC/DC	EPSL-1-B-L230	Neon Incandescence LED	Blue ■	12
6.3V AC/DC	EPSL-1-W-L6	Neon Incandescence LED	White □	12
12V AC/DC	EPSL-1-W-L12	Neon Incandescence LED	White □	12
24V AC/DC	EPSL-1-W-L24	Neon Incandescence LED	White □	12
110V AC/DC	EPSL-1-W-L110	Neon Incandescence LED	White □	12
230V AC/DC	EPSL-1-W-L230	Neon Incandescence LED	White □	12

EPSL-2 Series

Indicating Light With Two Lights

Technical data

Standard	EN / IEC60947-5-1
Rated current AC12	20A
Electric ratings	Up to 230VAC 50/60Hz
Rated insulation Voltage Ui	500V
Illumination	LED, Incandescence, neon
Life	Incandescence lamp \geq 1000h Neon lamp \geq 2000h LED \geq 30000h
Ambient temperature(°C)	-5~+40,max.95% humidity
Storage temperature(°C)	-40~+75
Connection capacity (mm ²)	1-16
Color	Red+Green
Type of terminal	Pin type
Protection degree	IP20
Mounting	35mm DIN rail



EPSL-3 Series

Indicating Light With Three Lights

Technical data

Standard	EN/IEC60947-5-1
Rated current AC12	20A
Electric ratings	Up to 230VAC 50/60Hz
Rated insulation Voltage Ui	500V
Illumination	LED, Incandescence, neon
Life	Incandescence lamp $\geq 1000h$ Neon lamp $\geq 2000h$ LED $\geq 30000h$
Ambient temperature(°C)	-5~+40,max.95% humidity
Storage temperature(°C)	-40~+75
Connection capacity (mm²) t	1-16
Color	Red+Blue+Green
Type of terminal	Pin type
Protection degree	IP20
Mounting	35mm DIN rail



SGS1 Series Surge Protective Device

Technical data

Standard	IEC61643-1
Protection	Protect electric system and on-loading electrical apparatus from thunder and instantaneous over-voltage
Ambient temperature(°C)	-40~+70
Number of poles	1P,2P,3P,4P
Maximum continuous Operating voltage Uc(V~)	275/320/385/440 V
Nominal discharge current In(8/20μs) (KA)	10/20/30/40/60 KA
Maximum discharge current Imax(8/20μs) (KA)	20/40/60/80/100 KA
Protection level Up(KV)	<1.3/1.4/1.5/1.6/1.7/1.8/2.2/2.5/3.0 KV
Response time t(ns)	<25
On-Off indicating window	Green: normal function Red: functionless, immediate replacement required
Type of terminal	Pin type
Installation	Mounting on 35mm DIN rail
Ground system	TT/TN



SGS1/1



SGS1/2



SGS1/3



SGS1/4

SGS1-D	Type	Poles	Uc(V~)	Discharge current		Up(KV)	Applicable grounding system
				Nominal(kA)	Max.(kA)		
 <p>SGS1-D/1</p>	SGS1-D/1-275-20	1	275	10	20	< 1.2	TT/TN
	SGS1-D/1-320-20	1	320	10	20	< 1.5	TT/TN
	SGS1-D/1-385-20	1	385	10	20	< 1.6	TT/TN
	SGS1-D/1-440-20	1	440	10	20	< 1.8	TT/TN
 <p>SGS1-D/2</p>	SGS1-D/2-275-20	2	275	10	20	< 1.2	TT/TN
	SGS1-D/2-320-20	2	320	10	20	< 1.5	TT/TN
	SGS1-D/2-385-20	2	385	10	20	< 1.6	TT/TN
	SGS1-D/2-440-20	2	440	10	20	< 1.8	TT/TN
 <p>SGS1-D/3</p>	SGS1-D/3-275-20	3	275	10	20	< 1.2	TT/TN
	SGS1-D/3-320-20	3	320	10	20	< 1.5	TT/TN
	SGS1-D/3-385-20	3	385	10	20	< 1.6	TT/TN
	SGS1-D/3-440-20	3	440	10	20	< 1.8	TT/TN
 <p>SGS1-D/4</p>	SGS1-D/4-275-20	4	275	10	20	< 1.2	TT/TN
	SGS1-D/4-320-20	4	320	10	20	< 1.5	TT/TN
	SGS1-D/4-385-20	4	385	10	20	< 1.6	TT/TN
	SGS1-D/4-440-20	4	440	10	20	< 1.8	TT/TN

SGS1-C



SGS1-C/1



SGS1-C/2



SGS1-C/3



SGS1-C/4

Type	Poles	Uc(V~)	Discharge current		Up(KV)	Applicable grounding system
			Nominal(kA)	Max.(kA)		
SGS1-C/1-275-40	1	275	20	40	< 1.6	TT/TN
SGS1-C/1-320-40	1	320	20	40	< 1.7	TT/TN
SGS1-C/1-385-40	1	385	20	40	< 1.8	TT/TN
SGS1-C/1-440-40	1	440	20	40	< 2.2	TT/TN
SGS1-C/2-275-40	2	275	20	40	< 1.6	TT/TN
SGS1-C/2-320-40	2	320	20	40	< 1.7	TT/TN
SGS1-C/2-385-40	2	385	20	40	< 1.8	TT/TN
SGS1-C/2-440-40	2	440	20	40	< 2.2	TT/TN
SGS1-C/3-275-40	3	275	20	40	< 1.6	TT/TN
SGS1-C/3-320-40	3	320	20	40	< 1.7	TT/TN
SGS1-C/3-385-40	3	385	20	40	< 1.8	TT/TN
SGS1-C/3-440-40	3	440	20	40	< 2.2	TT/TN
SGS1-C/4-275-40	4	275	20	40	< 1.6	TT/TN
SGS1-C/4-320-40	4	320	20	40	< 1.7	TT/TN
SGS1-C/4-385-40	4	385	20	40	< 1.8	TT/TN
SGS1-C/4-440-40	4	440	20	40	< 2.2	TT/TN

SGS1-B



SGS1-B/1



SGS1-B/2



SGS1-B/3



SGS1-B/4

Type	Poles	Uc(V~)	Discharge current		Up(KV)	Applicable grounding system
			Nominal(kA)	Max.(kA)		
SGS1-B/1-385-60	1	385	30	60	< 2.2	TT/TN
SGS1-B/1-440-60	1	440	30	60	< 2.5	TT/TN
SGS1-B/2-385-60	2	385	30	60	< 2.2	TT/TN
SGS1-B/2-440-60	2	440	30	60	< 2.5	TT/TN
SGS1-B/3-385-60	3	385	30	60	< 2.2	TT/TN
SGS1-B/3-440-60	3	440	30	60	< 2.5	TT/TN
SGS1-B/4-385-60	4	385	30	60	< 2.2	TT/TN
SGS1-B/4-440-60	4	440	30	60	< 2.5	TT/TN
SGS1-B/1-385-80	1	385	40	80	< 2.5	TT/TN
SGS1-B/1-385-100	1	385	60	100	< 2.5	TT/TN
SGS1-B/1-440-80	1	440	40	80	< 3.0	TT/TN
SGS1-B/1-440-100	1	440	60	100	< 3.0	TT/TN
SGS1-B/2-385-80	2	385	40	80	< 2.5	TT/TN
SGS1-B/2-385-100	2	385	60	100	< 2.5	TT/TN
SGS1-B/2-440-80	2	440	40	80	< 3.0	TT/TN
SGS1-B/2-440-100	2	440	60	100	< 3.0	TT/TN
SGS1-B/3-385-80	3	385	40	80	< 2.5	TT/TN
SGS1-B/3-385-100	3	385	60	100	< 2.5	TT/TN
SGS1-B/3-440-80	3	440	40	80	< 3.0	TT/TN
SGS1-B/3-440-100	3	440	60	100	< 3.0	TT/TN
SGS1-B/4-385-80	4	385	40	80	< 2.5	TT/TN
SGS1-B/4-385-100	4	385	60	100	< 2.5	TT/TN
SGS1-B/4-440-80	4	440	40	80	< 3.0	TT/TN
SGS1-B/4-440-100	4	440	60	100	< 3.0	TT/TN

1. Technical data

Technical data	Type	SGS1-D				SGS1-C				SGS1-B		
		275-20	320-20	385-20	440-20	275-40	320-40	385-40	440-40	385-60	385-80	385-100
Max.continuous operating vol. $U_c(V\sim)$		275V	320V	385V	440V	275V	320V	385V	440V	385V	385V	385V
Level of vol.protection($U_p<$)		1.2kV	1.5kV	1.6kV	1.8kV	1.6kV	1.7KV	1.8KV	2.2kv	2.2KV	2.5KV	2.5KV
Nominal discharge curent $I_n(8/20\mu s)kA$		10	10	10	10	20	20	20	20	30	40	60
Max. discharge current $I_{max}(8/20\mu s)kA$		20	20	20	20	40	40	40	40	60	80	100
Response time $t(ns)$		<25				<25				<25		
Pole width(mm)		18				18				18		
Colour		Orange				Grey				Red		
Protection degree		IP20				IP20				IP20		
Material of cover		PBT				PBT				PBT		
Circuit current		10~16A				25~32A				25~32A		
Wiring	L,N	2.5~35mm ²				2.5~35mm ²				2.5~35mm ²		
	PE	4.0~35mm ²				4.0~35mm ²				4.0~35mm ²		

2. How to select surge protectors

- The voltage should be $\leq U_c$;
- $U_p <$ maximum impulse withstands;
- Different protectors should be selected according to various grounding system and protection mode.

3. Allocation of surge protectors under TT system

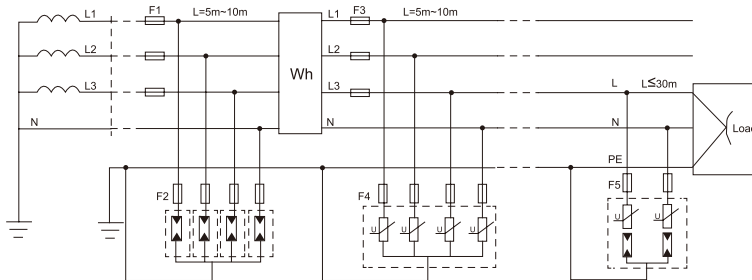

SGS1-B series surge protector
 Protection category: B
 Over-voltage mounting category:III
 Rated impulse withstand voltage:4KV
 Parameters of discharge: U_{imp} and I_n
 Master power distribution cabinet

SGS1-C series surge protector
 Protection category:C
 Over-voltage mounting category:II
 Rated impulse withstand voltage:2.5KV
 Parameters of discharge: I_{max} and I_n
 Branch power distribution cabinet

SGS1-D series surge protector
 Protection category:D
 Over-voltage mounting category:I
 Rated impulse withstand voltage:1.5KV
 Parameters of discharge: U_{oc} and I_{sc}
 Terminal of power distribution

4. Overall and Mounting Dimensions

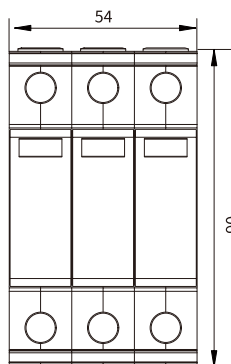

SGS1

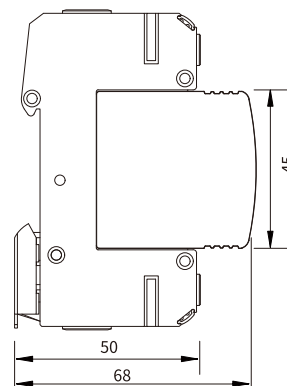

SGS1-DC Series Surge Protective Device

Technical data

Standard	IEC50539-11
Protection	Protect electric system and on-loading electrical apparatus from thunder and instaneous over-voltage
Ambient temperature (°C)	-40~+70
Number of poles	2P,3P
PV system operating voltage ucpv	1000/1500 V
Nominal discharge current In(8/20µs)(KA)	20KA
Maximum discharge current Imax(8/20µs)(KA)	40KA
Protection level Up(KV)	≤3.8/4.5
Response time t(ns)	<25
On-Off indicating window	Green: normal function Red: functionless, immediate replacement required
Type of terminal	Pin type
Installation	Mounting on 35mm DIN rail



SGS1-DC/2



SGS1-DC/3

SGS1-DC	Type	Poles	Uc(V~)	Discharge current		Up(KV)	Photovoltaic voltage
				Nominal(kA)	Max.(kA)		



SGS1-DC/2

SGS1-DC/2-500/40	2	500	20	40	≤2.5	500V
SGS1-DC/2-1000/40	2	1000	20	40	≤3.5	1000V



SGS1-DC/3

SGS1-DC/3-500/40	3	500	20	40	≤2.5	500V
SGS1-DC/3-1000/40	3	1000	20	40	≤3.5	1000V
SGS1-DC/3-1500/40	3	1500	20	40	≤5.5	1500V

Overall and Mounting Dimensions

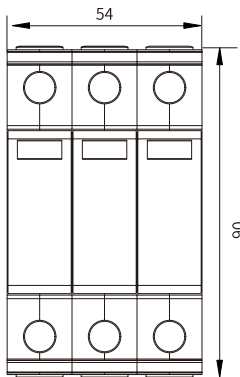

SGS1-C

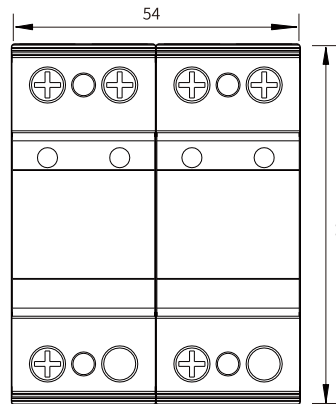
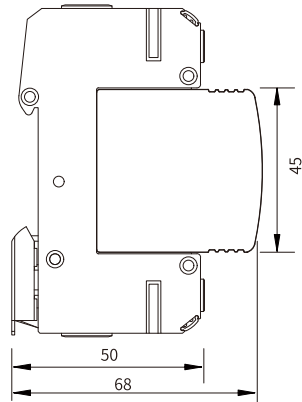

SGS1-B

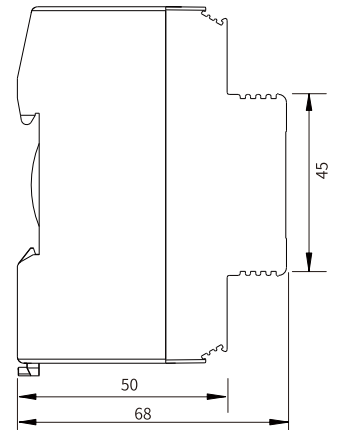

EPF-32 Series Fuse Holder and Links

Technical data

Standard	IEC 60947-3
Description	Fuse switch disconnecter with LED indicator
Number of Poles	1P,2P,3P,4P
Fuse size	10X38
Rated operational current Ie	2-32A
Rated operational voltage Ue	250VAC(1P)/500VAC(2P-4P)
Rated insulation voltage	500VAC
Rated impulse withstand voltage	4kV
Conditional short-circuit current	20kA
Utilization category with fuse	g G
Protection degree	IP20
Mounting method	Din rail installation



EPF-32-1P



EPF-32-2P



EPF-32-3P



EPF-32-4P

EPF-32 Fuse Holder and Links



EPF-32-1P



EPF-32-2P



EPF-32-3P



EPF-32-4P

Code No.	Fuse link size	Link current	Packing unit (holder)	Packing unit(link)
EPF-32-1 EPF-32X-1	10 X 38mm	2A	12	200
		4A	12	200
		6A	12	200
		10A	12	200
		16A	12	200
		20A	12	200
		25A	12	200
		32A	12	200
EPF-32-2 EPF-32X-2	10 X 38mm	2A	6	200
		4A	6	200
		6A	6	200
		10A	6	200
		16A	6	200
		20A	6	200
		25A	6	200
		32A	6	200
EPF-32-3 EPF-32X-3	10 X 38mm	2A	4	200
		4A	4	200
		6A	4	200
		10A	4	200
		16A	4	200
		20A	4	200
		25A	4	200
		32A	4	200
EPF-32-4 EPF-32X-4	10 X 38mm	2A	3	200
		4A	3	200
		6A	3	200
		10A	3	200
		16A	3	200
		20A	3	200
		25A	3	200
		32A	3	200

EPF-63 Series

Fuse Holder and Links

Technical data

Standard	IEC 60947-3
Description	Fuse switch disconnecter without null line
Number of Poles	1P,1P+N,2P,3P,3P+N
Fuse size	14X51
Rated operational current Ie	2-63A(500VAC)/2-32A(690VAC)
Rated operational voltage Ue	500VAC/690VAC
Rated insulation voltage	800VAC
Rated impulse withstand voltage	6kV
Conditional short-circuit current	100kA(500VAC)/50kA(690VAC)
Utilization category with fuse	g G
Protection degree	IP20
Mounting method	Din rail installation



EPF63-1P



EPF63-2P



EPF63-3P



EPF63-3P+N

EPF-63 Fuse Holder and Links



EPF63-1P



EPF63-1P+N



EPF63-2P



EPF63-3P



EPF63-3P+N

Code No.	Fuse link size	Link current	Packing unit (holder)	Packing unit (link)
EPF-63-1 EPF-63X-1	14 X 51mm	2A	12	100
		4A	12	100
		6A	12	100
		8A	12	100
		10A	12	100
		12A	12	100
		16A	12	100
		20A	12	100
		25A	12	100
		32A	12	100
		40A	12	100
50A	12	100		
63A	12	100		
EPF-63-1P+N EPF-63X-1P+N	14 X 51mm	2A	6	100
		4A	6	100
		6A	6	100
		8A	6	100
		10A	6	100
		12A	6	100
		16A	6	100
		20A	6	100
		25A	6	100
		32A	6	100
		40A	6	100
50A	6	100		
63A	6	100		
EPF-63-2 EPF-63X-2	14 X 51mm	2A	6	100
		4A	6	100
		6A	6	100
		8A	6	100
		10A	6	100
		12A	6	100
		16A	6	100
		20A	6	100
		25A	6	100
		32A	6	100
		40A	6	100
50A	6	100		
63A	6	100		
EPF-63-3 EPF-63X-3	14 X 51mm	2A	4	100
		4A	4	100
		6A	4	100
		8A	4	100
		10A	4	100
		12A	4	100
		16A	4	100
		20A	4	100
		25A	4	100
		32A	4	100
		40A	4	100
50A	4	100		
63A	4	100		
EPF-63-3+N EPF-63X-3+N	14 X 51mm	2A	3	100
		4A	3	100
		6A	3	100
		8A	3	100
		10A	3	100
		12A	3	100
		16A	3	100
		20A	3	100
		25A	3	100
		32A	3	100
		40A	3	100
50A	3	100		
63A	3	100		

EPF-125 Series

Fuse Holder and Links

Technical data

Standard	IEC 60947-3
Description	Fuse switch disconnecter without null line
Number of Poles	1P,1P+N,2P,3P,3P+N
Fuse size	22X58
Rated operational current Ie	10-125A(500VAC)/10-50A(690VAC)
Rated operational voltage Ue	500VAC/690VAC
Rated insulation voltage	800VAC
Rated impulse withstand voltage	6kV
Conditional short-circuit current	100kA(500VAC)/50kA(690VAC)
Utilization category with fuse	g G
Protection degree	IP20
Mounting method	Din rail installation

CE



EPF125-1P



EPF125-2P



EPF125-3P



EPF125-3P+N

EPF-125 Fuse Holder and Links



EPF125-1P

EPF-125-1
EPF-125X-1

22 X 58mm

Link current	Packing unit (holder)	Packing unit (link)
10A	12	50
16A	12	50
20A	12	50
25A	12	50
32A	12	50
40A	12	50
50A	12	50
63A	12	50
80A	12	50
100A	12	50
125A	12	50



EPF125-1P+N

EPF-125-1P+N
EPF-125X-1P+N

22 X 58mm

Link current	Packing unit (holder)	Packing unit (link)
10A	6	50
16A	6	50
20A	6	50
25A	6	50
32A	6	50
40A	6	50
50A	6	50
63A	6	50
80A	6	50
100A	6	50
125A	6	50



EPF125-2P

EPF-125-2
EPF-125X-2

22 X 58mm

Link current	Packing unit (holder)	Packing unit (link)
10A	6	50
16A	6	50
20A	6	50
25A	6	50
32A	6	50
40A	6	50
50A	6	50
63A	6	50
80A	6	50
100A	6	50
125A	6	50



EPF125-3P

EPF-125-3
EPF-125X-3

22 X 58mm

Link current	Packing unit (holder)	Packing unit (link)
10A	4	50
16A	4	50
20A	4	50
25A	4	50
32A	4	50
40A	4	50
50A	4	50
63A	4	50
80A	4	50
100A	4	50
125A	4	50



EPF125-4P

EPF-125-3+N
EPF-125X-3+N

22 X 58mm

Link current	Packing unit (holder)	Packing unit (link)
10A	3	50
16A	3	50
20A	3	50
25A	3	50
32A	3	50
40A	3	50
50A	3	50
63A	3	50
80A	3	50
100A	3	50
125A	3	50

THE INTELLIGENT EPSF Series

- Smart Home APP control
- Information feedback & Fault alarm
- Automatic detection & Transmission
- Real time monitoring & management
- Higher sensitivity & Lower consumption



- ① Power modular with surge protection
- ② Intelligent mini circuit breaker
- ③ Intelligent mini circuit breaker with leakage protection
- ④ Intelligent communication modular



ISO-9001



ISO-14001



ISO-45001



VDE



VDE



VDE



KEMA



KEMA



KEMA

⚠ Reserve the right to change the parameters without prior notice.



Address:
No.299 East Changhong Road,Mogan Mountain Hi-tech Industry
Development Zone,Deqing, Zhejiang,China

Tel: +86-572-8823878 8823666

Fax: +86-572-8822678 8822959

Email: maxge@maxge.com

Website: www.maxge.com

