



**MAXGE**

# MCCB

Moulded Case Circuit Breaker  
Automatic Transfer Switch



Address:  
No.299 East Changhong Road,Mogan Mountain Hi-tech Industry  
Development Zone,Deqing, Zhejiang,China  
Tel: +86-572-8820808  
Email: market@maxge.com  
Website: www.maxge.com  
Version: 202604 v1

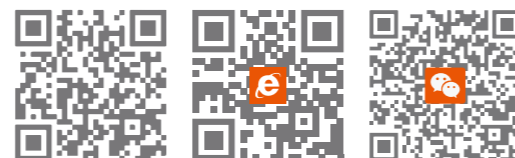

Committed to becoming a world-class manufacturer of intelligent electric

<https://www.maxge.com>



# ABOUT US

MAXGE PHASE II SMART FACTORY  
WUHU ANHUI

MAXGE Electric Technology Co., LTD was founded in 2006 with a registered capital of 50 million RMB. Its headquarter is located in Deqing County, Huzhou City, Zhejiang Province. It is a large-scale comprehensive high-tech enterprise integrating design, research and development, manufacturing, marketing and service.

Since its establishment, MAXGE has been professionally oriented and committed to the design and manufacturing of a series of products such as low voltage circuit breakers & controlgear for domestic, industrial protection and new energy power distribution, in order to meet user needs and provide high-quality solutions.

Currently MAXGE has a R&D team of more than 100 engineers and nearly 1,100+ employees, equipped with state of the art automatic production lines, CNAS affiliated laboratories and testing centers. MAXGE has obtained more than 100 invention and utility model patents, 10 software copyright, and participated in the formulation of national, industry and group standards.

There are over 133,000 square meters of Modern Intelligent Manufacturing Bases in Hangzhou&Huzhou,Zhejiang and Wuhu, Anhui.

The Huzhou factory covers an area of over 33,000 square meters, with a total investment of 500 million RMB. At present, there are 42 production lines in the automation workshops, among which the automatic assembly production line, semi-automatic assembly production line and automatic inspection line cover more than 90%.

At present, MAXGE has won many honors such as National High-tech Enterprise, National Specialized and Sophisticated "Little Giant", Zhejiang Enterprise Technology Center, Zhejiang High-level Enterprise R&D Center, Zhejiang Export Brand and Zhejiang Digital Workshop.

In the process of production and operation,we have obtained ISO9001, ISO14001 and ISO45001 and obtained SGS certifications, and the testing center has won the national CNAS laboratory certification. The products have obtained CE, CB, VDE, KEMA, TUV, INTERTEK, BV, ASTA, EAC, INMETRO certifications with reliable quality, and are exported to more than 60 countries and regions such as the European Union, the South America, Middle East, Africa, and Southeast Asia. We have multiple branches in the United Kingdom, Spain, Netherlands and Hong Kong, and we are dedicated to providing high-quality products and services to global customers.

<b>133,000 M<sup>2</sup></b>	<b>Phase I smart factory</b>	<b>Phase II smart factory</b>
	33,000 m <sup>2</sup>	100,000 m <sup>2</sup>



MAXGE PHASE I SMART FACTORY  
HUZHOU ZHEJIANG

**2** Smart  
Factories

**90%+** Automation

**100+** R&D  
Engineers



Making the best quality & cost performance Breakers

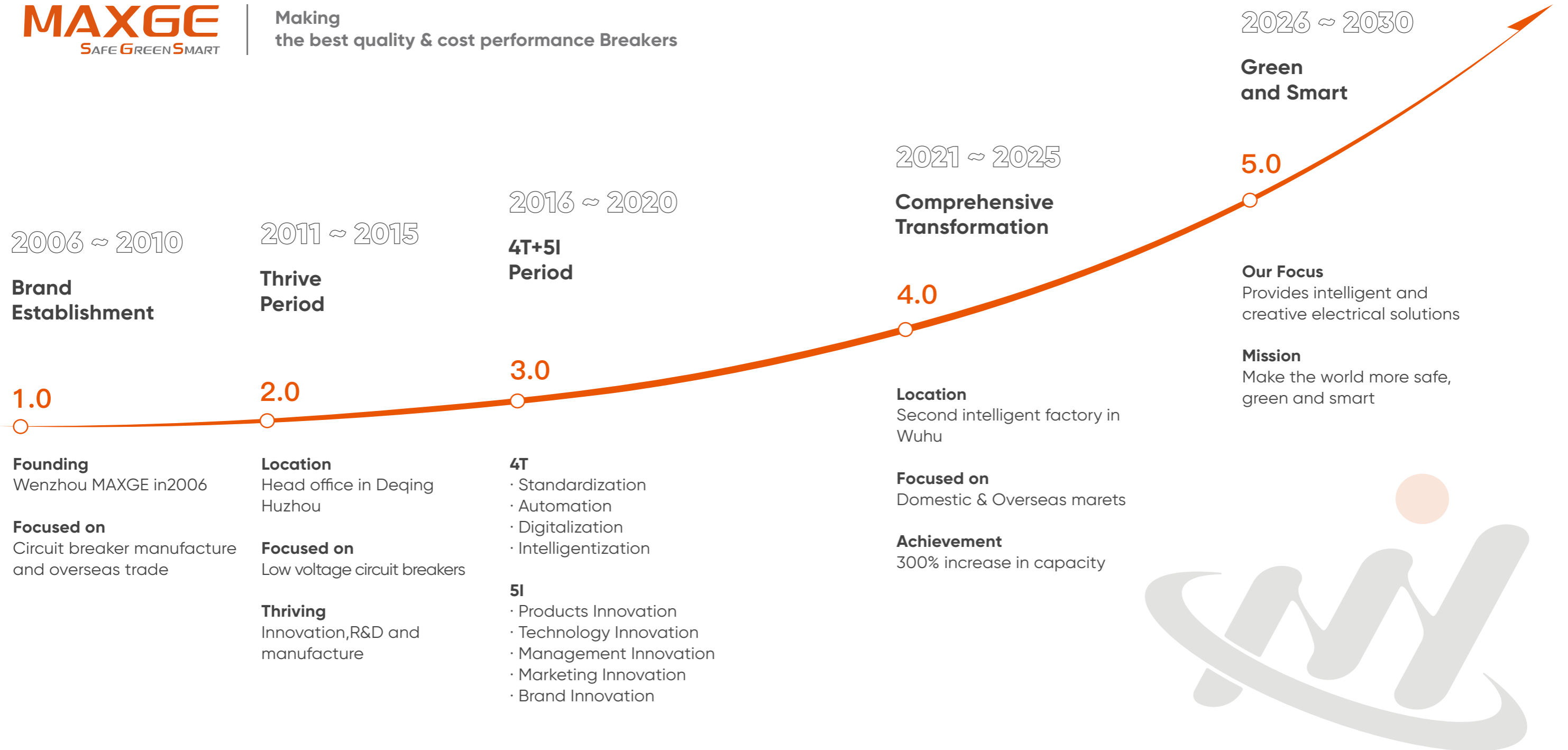

# CORPORATE CULTURE

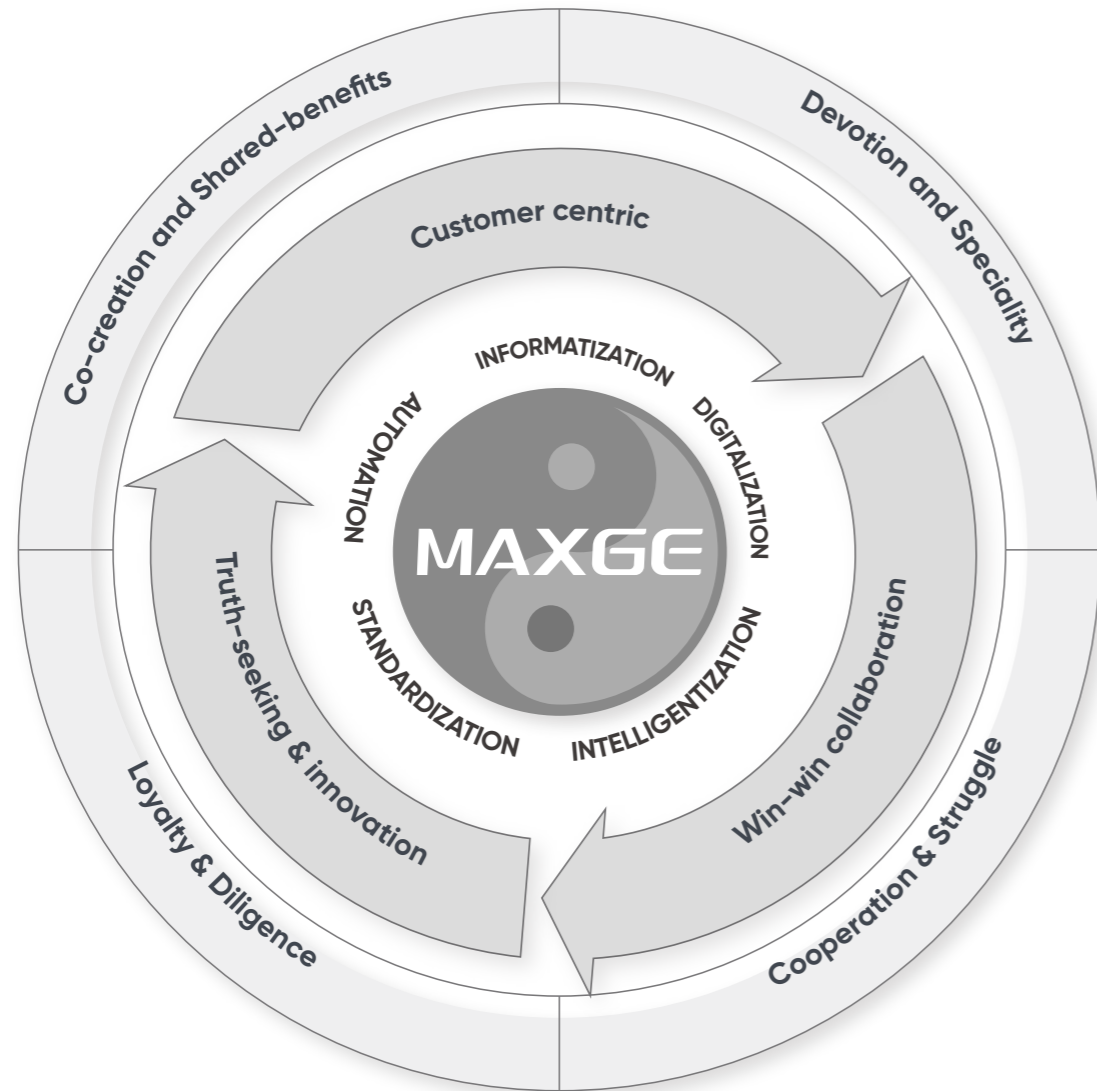

## One flower (Lotus)

The Heart of Altruism

- Remain true to the original aspiration
- Keep the mission firmly in mind
- Link the hearts tightly
- Be upright and integrity



## One tree (Bodhi tree)

The Tree of Wisdom

- "Stay Hungry"
- "Stay Foolish"
- Be wise and enlightened
- Self-growth and self-motivated



## One animal (Wukong)

The Spirit of Struggle

- Keep going, never give up
- Strive continuously to strengthen oneself
- Be loyal and trustworthy
- Have ample virtue & accommodate all things



### SHORT-TERM VISION

Making the best quality & cost performance Breakers

### LONG-TERM VISION

Committed to becoming a world-class manufacturer of intelligent electric

# CORPORATE AWARDS



National Specialized & Sophisticated "Little Giant"

National Green factory

Provincial Intellectual Property Demonstration Enterprise

Made in Zhejiang Group Standard Leading Enterprise

National Standard Setting Enterprise

National CNAS certified laboratory

Provincial High-tech Enterprise R&D Center

Provincial Enterprise Technology Center

Vice Chairman of Circuit breakers & Similar Equipment for Household Use

National High-tech Enterprise

Zhejiang Enterprise Research Institute

Provincial Credit Management Demonstration Enterprise

100+  
Invention Patents

7+  
National Standards

10+  
Software copyrights



# R & D STRENGTH

The institute introduced an intelligent testing system, combined with Internet of Things technology and cloud computing platform, which can realize real-time monitoring and remote data analysis, helping the R&D team to evaluate product performance and make adjustments and improvements.

The test categories cover low-voltage AC and low-voltage DC breaking tests, and the experimental coverage capacity ranges from 1.5kA to 15kA, meeting the requirements of low-voltage electrical product R&D tests, type tests, application simulation tests, new technology applications and product quality control.

The laboratory is also equipped with high-speed photography equipment to capture detailed changes and comprehensively analyze the performance of products under dynamic conditions, providing more reliable data support for the test results.

More than **100 sets** of various testing and analysis equipments  
**Covering more than 95%** of the testing capacity



## DEKRA CNAS TÜV Authoritative certification

美高电气科技有限公司检测中心  
Testing center of MAXGE Electric Technology Co., Ltd.

**DEKRA**

DEKRA CERTIFICATE OF APPROVAL  
for Customer's Testing Facility

德凯认可CTF客户实验室资质

Number: 3329162.00

美高电气科技有限公司检测中心  
Testing center of MAXGE Electric Technology Co., Ltd.

中国认可  
国际互认  
检测  
TESTING  
CNAS L18532

**ilac-MRA CNAS**

中国合格评定国家认可委员会  
China National Accreditation Service for Conformity Assessment

美高电气科技有限公司检测中心  
Testing center of MAXGE Electric Technology Co., Ltd.

**TÜV Rheinland**

TÜV莱茵目击实验室  
TÜV Rheinland Witness Laboratory

TÜV Rheinland  
Precisely Right.



# INTELLIGENT MANUFACTURING

MAXGE



## 01 Mold & Tooling Workshop

Equipped with made in Switzerland GF AgieCharmilles, Japan Sodick wire cutting machine & EDM machine and Vertical milling CNC processing area. At present, it has achieved independent design, manufacturing and production of press tools & molds, with a comprehensive manufacturing capacity of more than 30 sets per month. Now the complete mold manufacturing process has been established, and an independent mold quality inspection group is equipped to realize the full inspection of the mold processing to ensure the precision and accuracy of mold.



## 02 Stamping Workshop

Equipped with high & medium speed stamping presses, and auxiliary equipment. The average punching speed can reach 100 to 300 strokes per minute, the highest punching speed can reach 500 strokes per minute, and the monthly production capacity of the workshop is to cater stamped parts for 5 million MCB, 500K RCCB, 500K RCBO & 200K MCCB.



## 03 Spot Welding Workshop

Equipped with automatic coil winding machines, automatic braid compacting & cutting machines, automatic thermal and magnetic welding group assembly machines, automatic armature assembly machines, automatic pad printing on handle and latch holder machines. The automation level is over 90%, and it is mainly responsible for the production of welding groups required by the finished product workshop. Through the integrated technology of winding and welding, automatic welding production has been realized. Thermal assembly heat treatment process is adopted to improve first pass yield during thermal verification process.

## 04 Injection Molding Workshop

Equipped with 50 injection molding machines from 60 to 350 ton capacity, overhead cranes and auxiliary equipment such as automatic warpage prevention machines, mould temperature controllers, granulators. The automation level is over 90%, realizing an automatic and efficient production process. Adopted centralised material feeding system to improve production efficiency and realize effective utilization of resources. Smart humidifying room, use advanced humidification process to strengthen the mechanical properties of the product. MAXGE adapts online CCD image detection unit through which critical parts of mechanism undergoes 100% inspection to ensure delatch free breakers. Through CCD image detection equipment, efficient, accurate and reliable image detection and analysis can be realized to ensure product quality.





## 05 ACB Automatic Testing Line

The product will go through the steps of manual assembly, contact parameters tests such as trip force, trip distance, ACB & cradle assembly by robot ,mechanical operation test unit to verify internal accessories and motor, current characteristic test unit , high voltage and loop resistance test unit, & appearance inspection by CCD device. Automation level has reached 80% and the monthly detection capacity has reached more than 1500 ACB.



## 06 MCCB Automatic Workshop

It mainly produces Moulded Case Circuit Breaker such as fixed type, thermal adjustable type, thermal magnetic adjustable type, electronic type, ELCB type and DC type, as well as smart molded case circuit breaker. There are currently 8 automatic production lines & 4 lean u-shaped lines and the monthly production capacity reaches 250,000 units. It has realized the automatic assembly & inspection of the whole process, including contact parameters such as automatic open distance, overtravel, on-off, synchronicity, trip force, trip distance, loop resistance, lift force & routine tests such as magnetic, thermal, reliability & HV test. Test line also equipped with laser printing & final appearance inspection by CCD device. The automation level has reached to 80%

## 07 MCB Automatic Workshop

It mainly produces Miniature Circuit Breakers. There are 11 automatic production lines and 4 U-shaped lean production lines. At present, the average monthly production capacity can reach about 5 million poles. Equipped with automatic assembly, laser printing, riveting, Deltach test, terminal screw test, thermal calibration, cooling, thermal verification, automatic multi-pole assembly, magnetic test, on-off test and high voltage test, plasma arc cleaning, laser marking, pad printing, din clip fixing ,automatic packaging and other equipment, the automation level is over 90%. Through magnetic test, on-off test and high voltage test, to verify the response speed of the product and ensure that the power supply can be connected or disconnected stably. Adopt double-track automatic production line to improve production efficiency, add automatic tripping force measurement unit, conduct full inspection of products, and comprehensively monitor product quality.



## 08 RCCB Automatic Workshop

It mainly produces magnetic relay, electronic and electro-magnetic Residual Current Circuit Breakers, plastic and metal type single-phase and three-phase Distribution Boxes, Photovoltaic Combiner Boxes and control gear products. There are 4 automatic production lines and 4 U-shaped lean production lines. At present, the average monthly production capacity can reach about 400,000 poles. The key component of RCCB named magnetic relay is produced in a clean room of class one rating & temperature, humidity conditions are maintained within standard range. Equipped with magnetic relay workshop grinding machine, finished product workshop automatic demagnetization machine, automatic calibration bench, automatic on-off and HV test machine, magnetic relay automatic winding machine and other equipment, the detection automation level has reached 80%.



## 09 RCBO Automatic Workshop

It mainly produces Residual Current Circuit Breaker with Over Current Protection with different variants such as 2P Electronic RCBO, DPN RCBO, 1P Electronic RCBO, multipole RCBO, electro-magnetic type RCBO & Arc Fault Detection Device. There are 7 automatic production lines, 2 semi-automatic production lines and 3 U-shaped lean assembly lines. At present, the average monthly production capacity can reach about 600,000 poles. Equipped with automatic riveting, Deltach test, terminal screw test, magnetic test, on-off test, high voltage test, leakage current detection, thermal calibration, cooling, thermal verification, plasma arc cleaning, laser marking, pad printing and automatic packaging and other equipment, the automation level is over 85%.



**1 MCCB SERIES**

MCCB Fixed Type	01/04
MCCB Thermal Adjustable Type	05/08
MCCB Thermal & Magnetic Adjustable Type	09/12
MCCB Electronic Type With Knob	13/19
MCCB Electronic Type With LCD	20/25
MCCB With ELCB Type	26/28
MCCB Accessories	29/48
DC Moulded Case Circuit Breaker	49/49
High Voltage AC Moulded Case Circuit Breaker	50/50
Measuring Switch	51/52
Smart Moulded Case Circuit Breaker	53/54

**2 ATS SERIES**

ATS1 Series Automatic Transfer Switch	56/57
ATS2 Series Automatic Transfer Switch	58/59
ATS3 Series Automatic Transfer Switch	60/61
ATS4-GA Series Automatic Transfer Switch	62/67

MAXGE

**MCCB**  
Moulded Case Circuit Breaker



Product category	SGM series Moulded Case Circuit Breaker						
Design code	6						
Type code	Fixed Type (l)	Thermal Adjustable Type (s)	Thermal & Magnetic Adjustable Type (sm)	Electronic Type with Knobs (E) Electronic Type with LCD (i)	With ELCB Type (L)	Direct Current (DC)	High Voltage (HU)
Frame code	125A,160A,250A,400A,630A,800A/1000A,1600A						
Breaking capacity level	C*,L,Me,M,H,H <sup>+</sup>						
Pole	3P,4P						
Rated current	16-1600A						

e.g. : SGM 6 s - 125 M / 3P 125A



\*Line/load terminal : Immaterial

Ratings And Specifications										Fixed Type			
Frame Size													
	125e		125		160		250						
Model	SGM6-125				SGM6-160				SGM6-250				
Number of poles	3,4												
Rated current(A) In	16,20,25,30,32,40,50,60,63,70,75,80,90,100,125				16,20,25,30,32,40,50,63,70,75,80,100,125,140,150,160				100,125,140,150,160,175,180,200,225,250				
Magnetic tripping current (li)	10*In for 40-125 A 330A for 16-32 A				10*In for 50-160 A 480A for 16-40 A				10*In				
Standard	IEC60947-2												
Reference temperature	40°C/50°C/55°C												
Rated operational voltage	380/400/415V AC												
Rated insulation voltage Ui (V)	800				1000								
Rated impulse withstand voltage Uimp (kV)	8												
Breaking capacity level	Le	M	H	C*	L	M	H	H <sup>+</sup>	C*	L	M	H	H <sup>+</sup>
Rated ultimate short-circuit breaking capacity Icu(kA)	10	25	36	25	36	50	65	85	25	36	50	65	85
Rated service short-circuit breaking capacity Ics(kA)	10	18	25	25	25	36	50	66	25	25	36	50	66
Icu=Ics(KA)	10	18	25	25	25	36	50	66	25	25	36	50	66
Mechanical Endurance	for 16-100A		for 125A		for 16-100A		for 125-160A		7000				
Electrical Endurance	8500 1500		7000 1000		8500 1500		7000 1000		1000				
Accessories					Auxiliary contact(OF) Alarm switch(SD) Shunt tirp(MX)				Under-voltage release(MN) AC Motor Mechanism Extended Rotary Handle				

\*Line/load terminal : Immaterial

## Ratings And Specifications Fixed Type

Frame Size									
Model	SGM6-400	SGM6-630	SGM6-800 SGM6-1000	SGM6-1600					
Number of poles	3,4								
Rated current(A) In	250,275,280,300,315 350,400	450,500,550,600,630	For SGM6-800 630,700,770,800 For SGM6-1000 630,700,770,800,1000	1000,1250,1600					
Magnetic tripping current (li)	10*In/12*In								
Standard	IEC60947-2								
Reference temperature	40°C/50°C/55°C								
Rated operational voltage	380/400/415V AC								
Rated insulation voltage Ui (V)	1000								
Rated impulse withstand voltage Uimp (kV)	8								
Breaking capacity level	L	Me/M	H	M	H	M	H	M	H
Rated ultimate short-circuit breaking capacity Icu(kA)	50	85	100	85	100	85	100	66	85
Rated service short-circuit breaking capacity Ics(kA)	50	60	75	60	75	60	75	50	66
Icu=Ics(kA)	50	60	75	60	75	60	75	50	66
Mechanical Endurance	for 250-315A	for 350-400A	4000		2500		2500		
Electrical Endurance	7000	4000	1000		500		500		
Accessories	Auxiliary contact(OFF) Alarm switch(SD) Shunt trip(MX) Under-voltage release(MN) AC Motor Mechanism Extended Rotary Handle				Auxiliary contact(OFF) Alarm switch(SD) Shunt trip(MX) Under-voltage release(MN) AC Motor Mechanism				

## Product Dimension Drawing Fixed Type

**SGM6**

125,160,250,400,  
630,800/1000

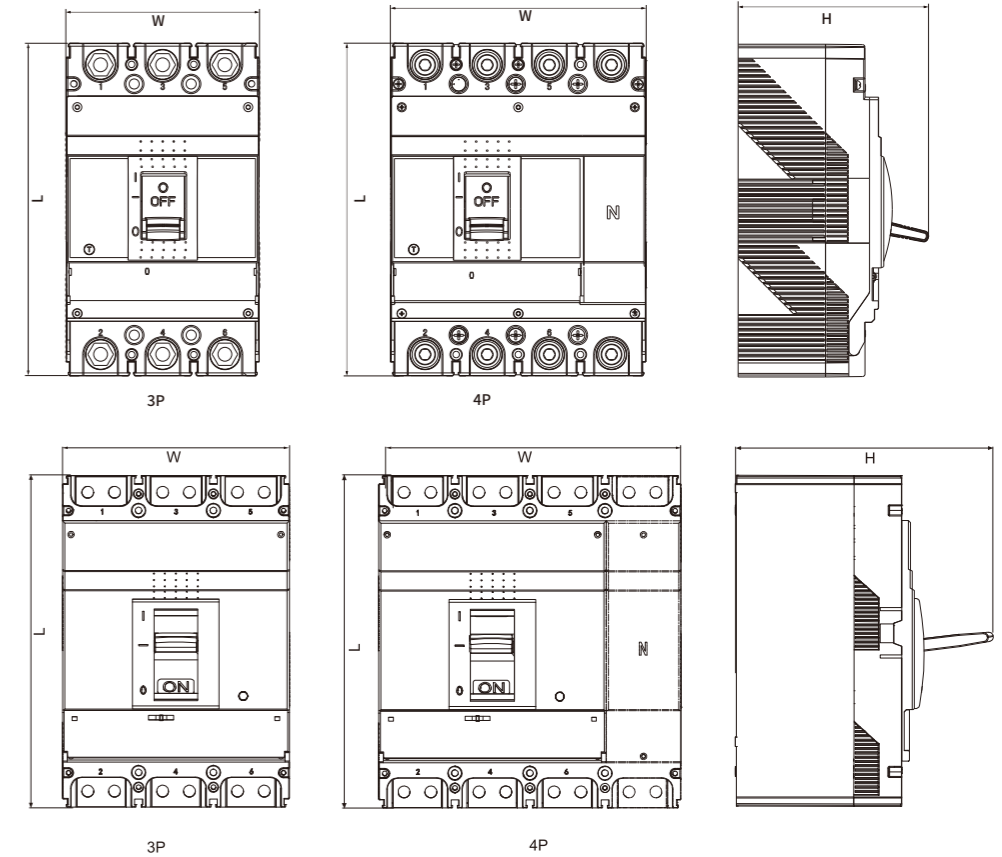

**SGM6**

1600

**SGM6 Dimensions mm(L×W×H)**

Frame Size	125	160	160 (H <sup>+</sup> )	250	250 (H <sup>+</sup> )	400 (Me)	400	630	800/1000	1600
3P	Length	133	155	155	165	165	257	257	257	310
	Width	75	92	92	107	107	140	150	150	212
	Height	81	93	99	100.5	110	152	152	152	242
4P	Length	133	155	155	165	165	257	257	257	310
	Width	100	122	122	142	142	183	197	197	282
	Height	81	93	99	100.5	110	152	152	152	242



# Thermal Adjustable Type

SGM6s Moulded Case Circuit Breaker



## Ratings And Specifications

## Thermal Adjustable Type

Frame Size	 125	 160	 250		
Model	SGM6s-125	SGM6s-160	SGM6s-250		
Number of poles	3,4				
Rated current(A) In	16,20,25,30, 32,40,50,60,63, 70,75,80,90,100, 125	30,32,40,50,63 70,75,80,100, 125,140,150,160	100,125,140,150, 160,175,180,200, 225,250		
Magnetic tripping current (Ii)	10*In for 40-125 A 330A for 16-32 A	10*In for 50-160 A 480A for 30-40 A	10*In		
Thermo-adjustable setting Ir(xIn)	0.8/0.9/1.0 or 0.7/0.85/1.0				
Standard	IEC60947-2				
Reference temperature	40°C/50°C/55°C				
Rated operational voltage	380/400/415V AC				
Rated insulation voltage Ui (V)	800	1000			
Rated impulse withstand voltage Uimp (kV)	8				
Breaking capacity level	M	H	L M H H* L M H H*		
Rated ultimate short-circuit breaking capacity Icu(kA)	25	36	36 50 65 85 36 50 65 85		
Rated service short-circuit breaking capacity Ics(kA)	18	25	25 36 50 66 25 36 50 66		
Icu=Ics(kA)	18	25	25 36 50 66 25 36 50 66		
Mechanical Endurance Electrical Endurance	for 16-100A	for 125A	for 30-100A	for 125-160A	2500 500
	8500 1500	7000 1000	8500 1500	7000 1000	
Accessories	Auxiliary contact(OF) Alarm switch(SD) Shunt tirp(MX) Under-voltage release(MN) AC Motor Mechanism Extended Rotary Handle				

## Ratings And Specifications Thermal Adjustable Type

Frame Size										
Model	SGM6s-400	SGM6s-630	SGM6s-800 SGM6s-1000	SGM6s-1600						
Number of poles	3,4									
Rated current(A) I <sub>n</sub>	250,275,280, 300,315,350,400	450,500,550,600,630	For SGM6s-800 630,700,770,800 For SGM6s-1000 630,700,770,800,1000	1000,1250,1600						
Magnetic tripping current (I <sub>i</sub> )	10*I <sub>n</sub> /12*I <sub>n</sub>									
Thermo-adjustable setting I <sub>r</sub> (xI <sub>n</sub> )	0.8/0.9/1.0									
Standard	IEC60947-2									
Reference temperature	40°C/50°C/55°C									
Rated operational voltage	380/400/415V AC									
Rated insulation voltage U <sub>i</sub> (V)	1000									
Rated impulse withstand voltage U <sub>imp</sub> (kV)	8									
Breaking capacity level	L	Me/M	H	L	M	H	M	H	M	H
Rated ultimate short-circuit breaking capacity I <sub>cu</sub> (kA)	50	85	100	50	85	100	85	100	66	85
Rated service short-circuit breaking capacity I <sub>cs</sub> (kA)	50	60	75	50	60	75	60	75	50	66
I <sub>cu</sub> =I <sub>cs</sub> (kA)	50	60	75	50	60	75	60	75	50	66
Mechanical Endurance	for 250-315A		for 350-400A		4000		2500		2500	
Electrical Endurance	7000 1000		4000 1000		1000		500		500	
Accessories	Auxiliary contact(OFF) Alarm switch(SD) Shunt trip(MX) Under-voltage release(MN) AC Motor Mechanism				Auxiliary contact(OFF) Alarm switch(SD) Shunt trip(MX) Under-voltage release(MN) AC Motor Mechanism					

## Product Dimension Drawing Thermal Adjustable Type

**SGM6s**  
125,160,250,400,  
630,800,1000

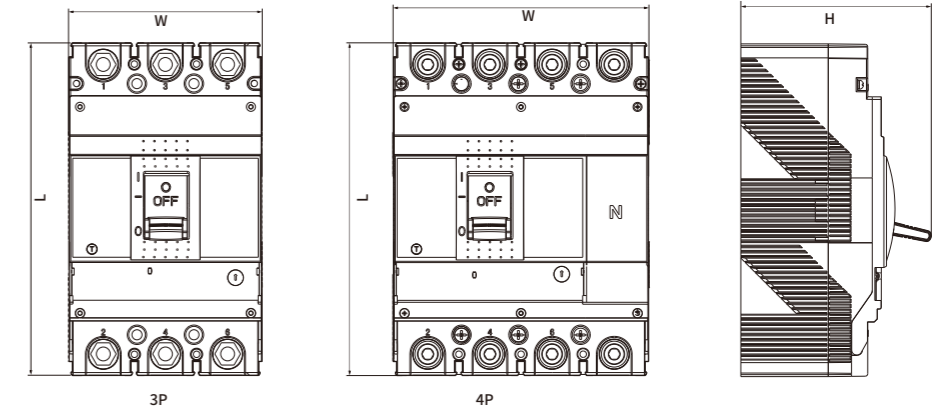

**SGM6s**  
1600

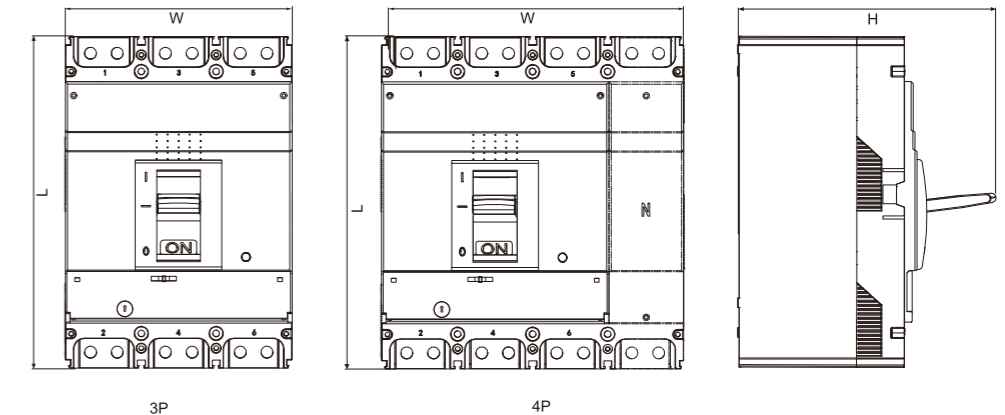



SGM6s Dimensions mm(L×W×H)										
Frame Size	125	160	160 (H <sup>+</sup> )	250	250 (H <sup>+</sup> )	400(Me)	400	630	800/1000	1600
3P	Length	133	155	155	165	165	257	257	257	280
	Width	75	92	92	107	107	140	150	150	210
	Height	81	93	99	100.5	110	152	152	152	155
4P	Length	133	155	155	165	165	257	257	257	280
	Width	100	122	122	142	142	183	197	197	280
	Height	81	93	99	100.5	110	152	152	152	155

# Thermal & Magnetic Adjustable Type





SGM6sm Moulded Case Circuit Breaker



## Ratings And Specifications Thermal & Magnetic Adjustable Type

Frame Size	 160	 250						
Model	SGM6sm-160	SGM6sm-250						
Number of poles	3,4							
Rated current(A) In	30,32,40,50,63 70,75,80,100, 125,140,150,160	100,125,140,150, 160,175,180,200, 225,250						
Magnetic tripping current (Ii)	10*In							
Thermo-adjustable setting Ir(xIn)	0.8/0.9/1.0 or 0.7/0.85/1.0							
Magnetic-adjustable setting Ii(xIn)	6-8-10							
Standard	IEC60947-2							
Reference temperature	40°C/50°C/55°C							
Rated operational voltage	380/400/415V AC							
Rated insulation voltage Ui (V)	1000							
Rated impulse withstand voltage Uimp (kV)	8							
Breaking capacity level	L	M	H	H*	L	M	H	H*
Rated ultimate short-circuit breaking capacity Icu(kA)	36	50	65	85	36	50	65	85
Rated service short-circuit breaking capacity Ics(kA)	25	36	50	66	25	36	50	66
Icu=Ics(kA)	25	36	50	66	25	36	50	66
Mechanical Endurance	for 30-100A		for 125-160A		2500			
Electrical Endurance	8500 1500		7000 1000		500			
Accessories	Auxiliary contact(OF) Alarm switch(SD) Shunt trip(MX) Under-voltage release(MN) AC Motor Mechanism Extended Rotary Handle Fixed magnetic trip							

Ratings And Specifications Thermal & Magnetic Adjustable Type

Frame Size										
Model	SGM6sm-400	SGM6sm-630	SGM6sm-800 SGM6sm-1000	SGM6sm-1600						
Number of poles	3,4									
Rated current(A) In	250,275,280 300,315,350,400	450,500,550,600,630	For SGM6sm-800 630,700,770,800 For SGM6sm-1000 630,700,770,800,1000	1000,1250,1600						
Magnetic tripping current (li)	10*In/12*In									
Thermo-adjustable setting Ir(xIn)	0.8/0.9/1.0									
Magnetic-adjustable setting li(xIn)	6-8-10									
Standard	IEC60947-2									
Reference temperature	40°C/50°C/55°C									
Rated operational voltage	380/400/415V AC									
Rated insulation voltage Ui (V)	1000									
Rated impulse withstand voltage Uimp (kV)	8									
Breaking capacity level	L	Me/M	H	L	M	H	M	H	M	H
Rated ultimate short-circuit breaking capacity Icu(kA)	50	85	100	50	85	100	85	100	66	85
Rated service short-circuit breaking capacity Ics(kA)	50	60	75	50	60	75	60	75	50	66
Icu=Ics(kA)	50	60	75	50	60	75	60	75	50	66
Mechanical Endurance	for 250-315A		for 350-400A		4000		2500		2500	
Electrical Endurance	7000	4000	1000		500		500		500	
Accessories	Auxiliary contact(OFF) Alarm switch(SD) Shunt trip(MX) Under-voltage release(MN) AC Motor Mechanism Rotary handle operating mechanism				Auxiliary contact(OFF) Alarm switch(SD) Shunt trip(MX) Under-voltage release(MN) AC Motor Mechanism					

Product Dimension Drawing Thermal Magnetic Adjustable Type

SGM6sm  
160,250,400,630,800/1000

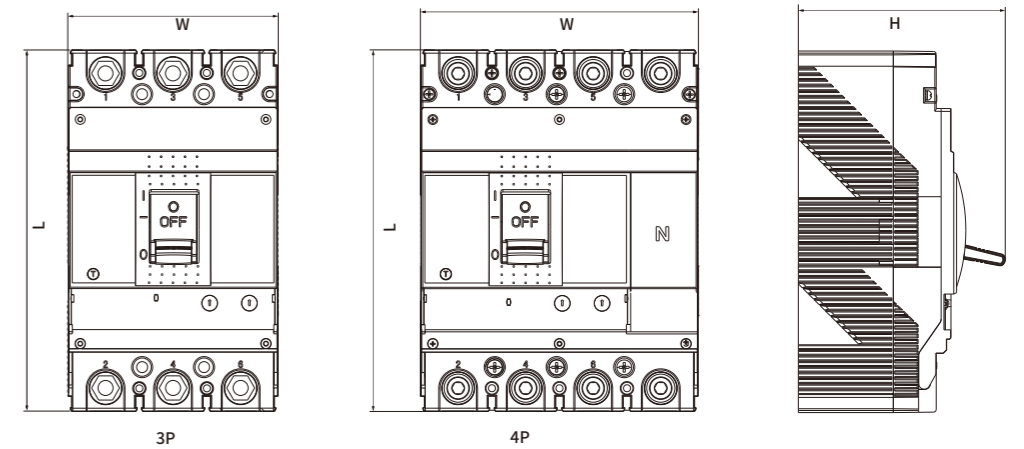

SGM6sm  
1600

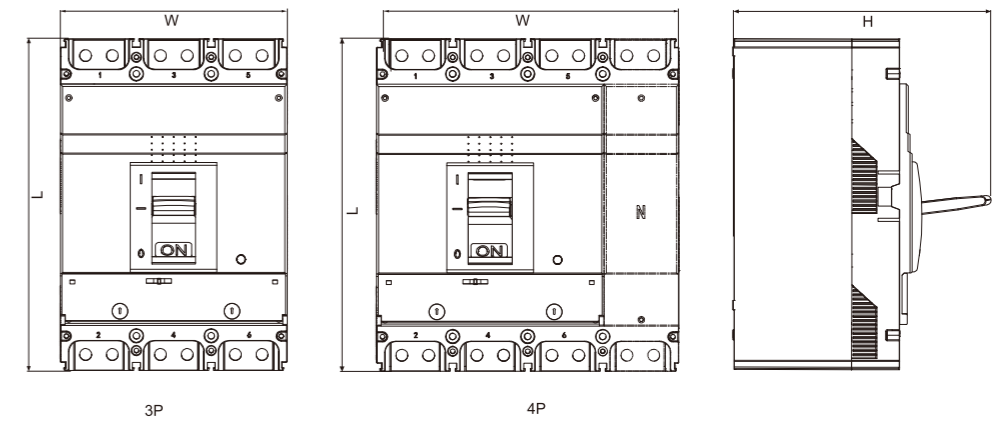

SGM6sm Dimensions mm(L×W×H)

Frame Size	160	160 (H <sup>+</sup> )	250	250 (H <sup>+</sup> )	400 (Me)	400	630	800/1000	1600
3P	Length	155	155	165	165	257	257	280	310
	Width	92	92	107	107	140	150	210	212
	Height	93	99	100.5	110	152	152	155	242
4P	Length	155	155	165	165	257	257	280	310
	Width	122	122	142	142	183	197	280	282
	Height	93	99	100.5	110	152	152	155	242



# Electronic Type With Knob

SGM6E Moulded Case Circuit Breaker





## Ratings And Specifications

## Electronic Type With Knob

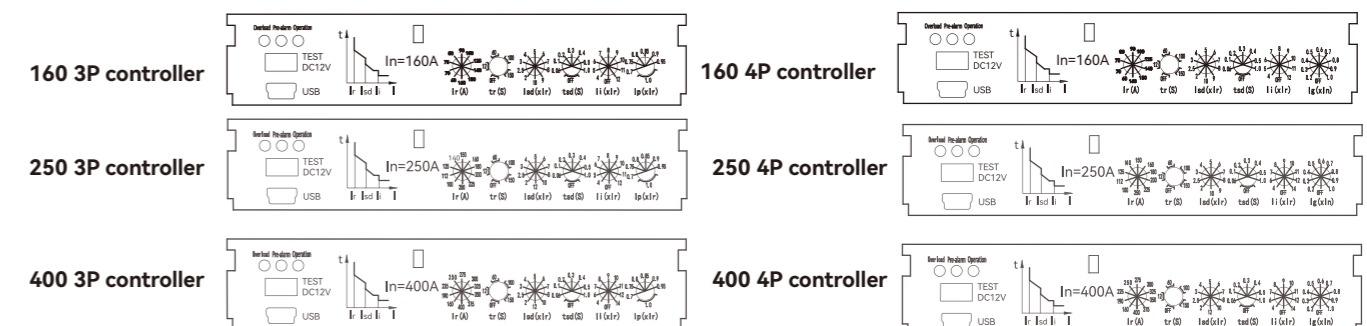
Frame Size	 160	 250	 400							
Model	SGM6E-160	SGM6E-250	SGM6E-400							
Number of poles	3,4									
Rated current(A) In	63,100,125,160	125,160,200,250	250,300,315,320,400							
Standard	IEC60947-2									
Rated operational voltage	380/400/415V AC									
Rated insulation voltage Ui (V)	1000									
Rated impulse withstand voltage Uimp (kV)	8									
Selectivity category	A			B						
Rated short-time with stand current (Icw)	A			8 kA - 1 s						
Breaking capacity level	L	M	H	H*	L	M	H	M	H	
Rated ultimate short-circuit breaking capacity Icu(kA)	36	50	65	85	36	50	65	85	100	
Rated service short-circuit breaking capacity Ics(kA)	25	36	50	66	25	36	50	60	75	
Icu=Ics(kA)	25	36	50	66	25	36	50	60	75	
Mechanical Endurance	for 60-100A		for 125-160A		7000			for 250-315A		for 320-400A
Electrical Endurance	8500		7000		1000			7000		4000
Accessories	Auxiliary contact(OF) Alarm switch(SD) Shunt trip(MX) Under-voltage release(MN) AC Motor Mechanism Extended Rotary Handle									



## Ratings And Specifications Electronic Type With Knob

Frame Size			
Model	SGM6E-630	SGM6E-800 SGM6E-1000	SGM6E-1600
Number of poles	3,4		
Rated current(A) In	250,300,315,320 400,500,630	For SGM6E-800:630,800 For SGM6E-1000:630,800,1000	1000,1250,1600
Standard	IEC60947-2		
Reference temperature	40°C/50°C/55°C		
Rated operational voltage	380/400/415V AC		
Rated insulation voltage Ui (V)	1000		
Rated impulse withstand voltage Uimp (kV)	8		12
Mention Selectivity category	B		
Rated short-time with stand current (Icw)	8 kA - 1 s	10kA - 1 s	20kA - 1 s
Breaking capacity level	M   H	M   H	M   H
Rated ultimate short-circuit breaking capacity Icu(kA)	85   100	85   100	66   85
Rated service short-circuit breaking capacity Ics(kA)	60   75	60   75	50   66
Icu=Ics(kA)	60   75	60   75	50   66
Mechanical Endurance	for 250-315A 7000	for 320-630A 4000	2500
Electrical Endurance	1000	1000	500
Accessories	Auxiliary contact(OF) Alarm switch(SD) Shunt trip(MX) Under-voltage release(MN) AC Motor Mechanism Extended Rotary Handle	Auxiliary contact(OF) Alarm switch(SD) Shunt trip(MX) Under-voltage release(MN) AC Motor Mechanism Extended Rotary Handle	Auxiliary contact(OF) Alarm switch(SD) Shunt trip(MX) Under-voltage release(MN) AC Motor Mechanism

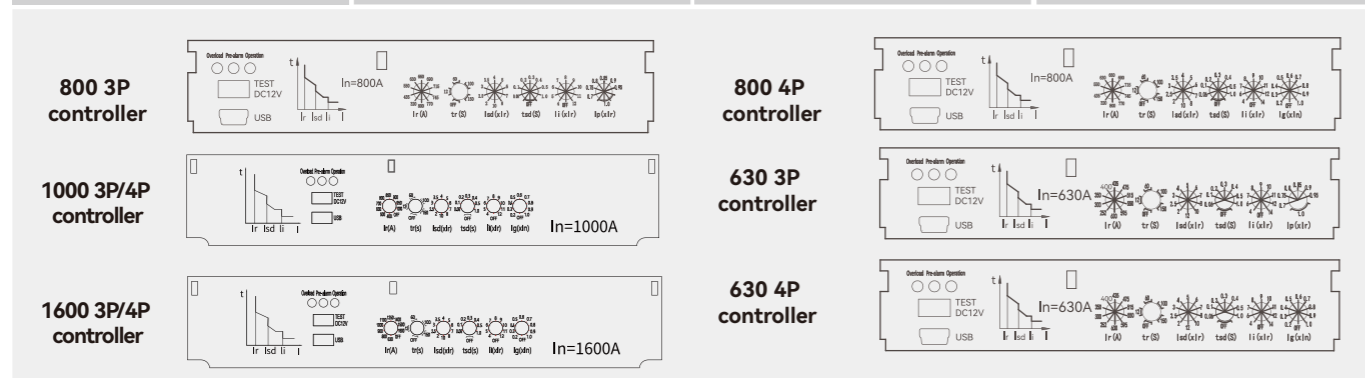

## Product Dimension Drawing Electronic Type With Knob

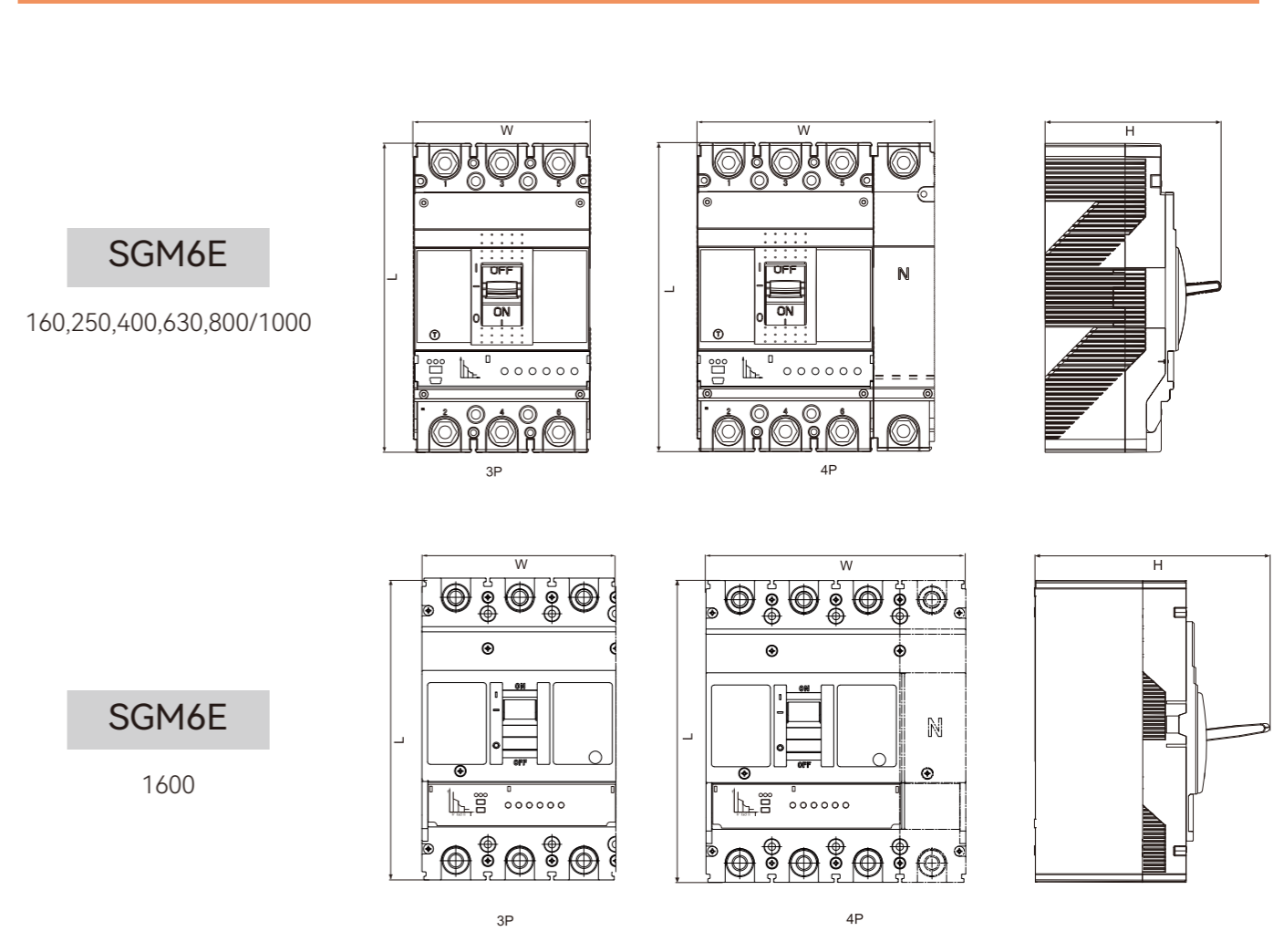

		SGM6E Dimensions mm(L×W×H)						
Frame Size		160	160 (H <sup>1</sup> )	250	400	630	800/1000	1600
3P	Length	155	155	165	257	257	280	310
	Width	92	92	107	150	150	210	212
	Height	93	99	100.5	152	152	155	242
4P	Length	155	155	165	257	257	280	310
	Width	122	122	142	197	197	280	282
	Height	93	99	100.5	152	152	155	242

Setting Parameters		Electronic Type With Knob												
Frame Size	SGM6E-160A				SGM6E-250A				SGM6E-400A					
Rated current In(A)	63	100	125	160	125	160	200	250	250	300	315	320	400	
Ir(A) Long Delay Current Setting	25-28-32 36-40-45 50-56-60 63A	40-45-50 56-63-70 75-80-90 100A	50-63-70 75-80-85 90-95-100 125A	63-70-75 80-90-100 125-140-150 160A	50-63-70 75-80-85 90-95-100 125A	63-70-75 80-90-100 125-140-150 160A	80-90-100 110-125-140 150-160-180 200A	100-112-125 140-150 160-180-200 225-250A	100-112-125 140-150 160-180-200 225-250A	120-142-168 188-206 225-243-262 281-300A	126-150-177 196-216 236-255-275 295-315A	128-152-180 200-220 240-260-280 300-320A	160-190-225 250-275 300-325-350 375-400A	160-190-225 250-275 300-325-350 375-400A
tr(S) Long Delay Time	12-60-100-150 sec + OFF													
Isd(A) Short Circuit Protection Of Low Level Faults	2-2.5-3-4-5-6-7-8-9-10 x Ir(A)								2-2.5-3-4-5-6-7-8-10-12 x Ir(A)					
tsd (S) short time	0.06-0.1-0.2-0.3- 0.4-0.5-1.0 sec + OFF													
Ii(A) Short Circuit Protection Of High level Faults	4-5-6-7-8-9-10-11-12 x Ir(A)+ OFF								4-6-7-8-9-10-11-12-14 x Ir(A)+ OFF					
Ip(A) Pre Trip Alarm Setting Multiple	0.7-0.75-0.8-0.85-0.9-0.95 1.0 x Ir(A)													
For 4p Ig(A) Ground Fault Pickup Current	0.2-0.3-0.4-0.5-0.6-0.7-0.8-0.9 1.0 x In+ OFF													
For 4p tg(S) Ground Fault Pickup Time	Fixed for 0.4sec													



Setting Parameters		Electronic Type With Knob									
Frame Size	SGM6E-630A								SGM6E-800A		
Rated current In(A)	250	300	315	320	400	500	600	630	630	800	
Ir(A) Long Delay Current Setting	100-112-125 140-150 160-180-200 225-250A	120-142-168 188-206 225-243-262 281-300A	126-150-177 196-216 236-255-275 295-315A	128-152-180 200-220 240-260-280 300-320A	160-190-225 250-275 300-325-350 375-400A	200-238-278 317-345 377-408-436 472-500A	240-285-333 380-414 452-490-523 566-600A	252-300-350 400-435-475- 515-550- 595-630A	252-300-350 400-435 475-515 550-595-630A	320-435-550 630-660 690-715-745 770-800A	
tr(S) Long Delay Time	12-60-100-150 sec + OFF								12-60-80 sec + OFF		
Isd(A) Short Circuit Protection Of Low Level Faults	2-2.5-3-4-5-6-7-8-10-12 x Ir(A)									2-2.5-3-4-5-6- 7-8-9 x Ir(A)	
tsd (S) short time	0.06-0.1-0.2-0.3- 0.4-0.5-1.0 sec + OFF										
Ii(A) Short Circuit Protection Of High level Faults	4-6-7-8-9-10-11-12-14 x Ir(A)+ OFF								4-5-6-7-8-9 x Ir(A)+ OFF	4-5-6-7-8-9-10 x Ir(A)+ OFF	
Ip(A) Pre Trip Alarm Setting Multiple	0.7-0.75-0.8-0.85-0.9-0.95 1.0 x Ir(A)										
For 4p Ig(A) Ground Fault Pickup Current	0.2-0.3-0.4-0.5-0.6-0.7-0.8-0.9 1.0 x In+ OFF										
For 4p tg(S) Ground Fault Pickup Time	Fixed for 0.4sec										



Setting Parameters		Electronic Type With Knob				
Frame Size	SGM6E-1000A			SGM6E-1600A		
Rated current In(A)	630	800	1000	1000	1250	1600
Ir(A) Long Delay Current Setting	252-300-350 400-435-475-515 550-595-630A	320-435-550 630-660 690-715-745 770-800A	400-500-630 700-800-850 900-950 1000A	400-500-630 700-800-850 900-950 1000A	500-630 700-800 900-1000 1100-1200 1250A	630-800 900-1000 1100-1250 1400-1500 1600A
tr(S) Long Delay Time	12-60-80 sec + OFF			12-60-100-150 sec + OFF		
Isd(A) Short Circuit Protection Of Low Level Faults	2-2.5-3-4-5-6-7-8-9x Ir(A)			2-2.5-3-3.5-4-5-6-7-8-10 x Ir(A)		
tsd (S) short time	0.06-0.1-0.2-0.3- 0.4-0.5-1.0 sec + OFF					
Ii(A) Short Circuit Protection Of High level Faults	4-5-6-7-8-9 xIr(A) + OFF	4-5-6-7-8-9-10xIr(A)+ OFF		4-5-6-7-8-9-10-11-12 xIr(A) + OFF		
Ip(A) Pre Trip Alarm Setting Multiple	0.7-0.75-0.8-0.85-0.9-0.95 1.0 x Ir(A)			Fixed 0.9x Ir(A)		
For 4p Ig(A) Ground Fault Pickup Current	0.4-0.5-0.6-0.7-0.8-0.9-1.0 x In+ OFF			0.2-0.3-0.4-0.5-0.6-0.7-0.8-0.9 1.0 x In+ OFF		
For 4p tg(S) Ground Fault Pickup Time	Fixed for 0.4sec					

# Electronic Type With LCD

iSGM6E Moulded Case  
Circuit Breaker



Ratings And Specifications					Electronic Type With LCD					
Frame Size										
	160				250			400		
Model	iSGM6E-160				iSGM6E-250			iSGM6E-400		
Number of poles	3,4									
Rated current(A) In	63,100,125,160				125,160,200,250			250,300,315,320,400		
Standard	IEC60947-2									
Reference temperature	40°C/50°C/55°C									
Rated operational voltage	380/400/415V AC									
Rated insulation voltage Ui (V)	1000									
Rated impulse withstand voltage Uimp (kV)	8									
Selectivity category	A				B					
Rated short-time with stand current (Icw)					8 kA - 1 s					
Breaking capacity level	L	M	H	H <sup>+</sup>	L	M	H	M	H	
Rated ultimate short-circuit breaking capacity Icu(kA)	36	50	65	85	36	50	65	85	100	
Rated service short-circuit breaking capacity Ics(kA)	25	36	50	66	25	36	50	60	75	
Icu=Ics(kA)	25	36	50	66	25	36	50	60	75	
Mechanical Endurance	for 63-100A		for 125-160A		7000			for 250-315A		for 320-400A
Electrical Endurance	8500 1500		7000 1000		1000			7000 1000		4000 1000
Accessories	Auxiliary contact(OFF) Alarm switch(SD) Shunt trip(MX) Under-voltage release(MN) AC Motor Mechanism Extended Rotary Handle									

Ratings And Specifications					Electronic Type With LCD				
Frame Size									
	630				800/1000			1600	
Model	iSGM6E-630				iSGM6E-800 iSGM6E-1000			iSGM6E-1600	
Number of poles	3,4								
Rated current(A) In	250,300,315,320 400,500,630				For iSGM6E-800 630,800			1000,1250,1600	
					For iSGM6E-1000 630,800,1000				
Standard	IEC60947-2								
Reference temperature	40°C/50°C/55°C								
Rated operational voltage	380/400/415V AC								
Rated insulation voltage Ui (V)	1000								
Rated impulse withstand voltage Uimp (kV)	8								
Selectivity category	B								
Rated short-time with stand current (Icw)	8 kA - 1 s		10 kA - 1 s			20 kA - 1 s			
Breaking capacity level	M	H	M	H	M	H	M	H	
Rated ultimate short-circuit breaking capacity Icu(kA)	85	100	85	100	66	85			
Rated service short-circuit breaking capacity Ics(kA)	60	75	60	75	50	66			
Icu=Ics(kA)	60	75	60	75	50	66			
Mechanical Endurance	4000				2500			2500	
Electrical Endurance	1000				500			500	
Accessories	Auxiliary contact(OFF) Alarm switch(SD) Shunt trip(MX) Under-voltage release(MN) AC Motor Mechanism Extended Rotary Handle								

## Product Dimension Drawing Electronic Type With LCD

**iSGM6E**  
160,250,400,630,800/1000

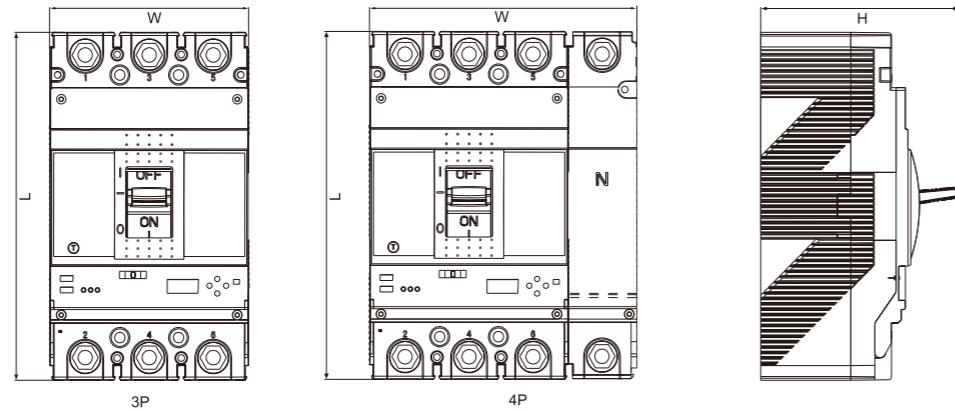

**iSGM6E**  
1600

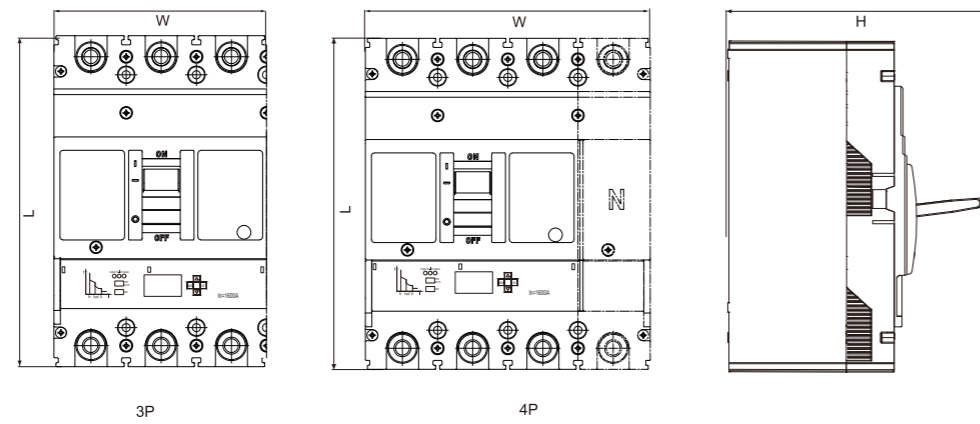

iSGM6E Dimensions mm(L×W×H)								
Frame Size		160	160 (H <sup>+</sup> )	250	400	630	800/1000	1600
3P	Length	155	155	165	257	257	280	310
	Width	92	92	107	150	150	210	212
	Height	93	99	100.5	152	152	155	242
4P	Length	155	155	165	257	257	280	310
	Width	122	122	142	197	197	280	282
	Height	93	99	100.5	152	152	155	242

## Setting Parameters Electronic Type With LCD

Frame Size	iSGM6E-160A				iSGM6E-250A				iSGM6E-400A				
Rated current In(A)	63	100	125	160	125	160	200	250	250	300	315	320	400
Ir(A) Long Delay Current Setting	25-63A in steps of 1A	40-100A in steps of 1A	50-125A in steps of 1A	63-160A in steps of 1A	50-125A in steps of 1A	63-160A in steps of 1A	80-200A in steps of 1A	100-250A in steps of 1A	100-250A in steps of 1A	120-300A in steps of 1A	126-315A in steps of 1A	128-320A in steps of 1A	160-400A in steps of 1A
tr(S) Long Delay Time	12-150 sec in steps of 1 sec+OFF												
I <sub>sd</sub> (A) Short Circuit Protection Of Low Level Faults	126-630A in steps of 1A	200-1000A in steps of 1A	250-1250A in steps of 1A	320-1600A in steps of 1A	250-1250A in steps of 1A	320-1600A in steps of 1A	400-2000A in steps of 1A	500-2500A in steps of 1A	200-3000A in steps of 1A	240-3600A in steps of 1A	252-3780A in steps of 1A	256-3840A in steps of 1A	320-4800A in steps of 1A
tsd (S) short time	0.06-1 sec in steps of 0.01 sec+OFF												
I <sub>i</sub> (A) Short Circuit Protection Of High level Faults	100-756 in steps of 1A + OFF	252-756A in steps of 1A + OFF	400-1200A in steps of 1A + OFF	640-1920A in steps of 1A + OFF	500-1250A in steps of 1A + OFF	640-1920A in steps of 1A + OFF	800-2400A in steps of 1A + OFF	1000-3000A in steps of 1A + OFF	400-3500A in steps of 1A + OFF	480-4200A in steps of 1A + OFF	504-4410A in steps of 1A + OFF	512-4480A in steps of 1A + OFF	640-5600A in steps of 1A + OFF
I <sub>p</sub> (A) Pre Trip Alarm Setting Multiple	44-63A in steps of 1A	70-100A in steps of 1A	87-125A in steps of 1A	112-160A in steps of 1A	87-125A in steps of 1A	112-160A in steps of 1A	140-200A in steps of 1A	175-250A in steps of 1A	70-250A in steps of 1A	84-300A in steps of 1A	88.2-315A in steps of 1A	89.6-320A in steps of 1A	112-400A in steps of 1A
For 4p I <sub>g</sub> (A) Ground Fault Pickup Current	12.6-63A in steps of 1A + OFF	20-100A in steps of 1A + OFF	25-125A in steps of 1A + OFF	32-160A in steps of 1A + OFF	25-125A in steps of 1A + OFF	32-160A in steps of 1A + OFF	40-200A in steps of 1A + OFF	50-250A in steps of 1A + OFF	50-250A in steps of 1A + OFF	60-300A in steps of 1A + OFF	63-315A in steps of 1A + OFF	64-320A in steps of 1A + OFF	80-400A in steps of 1A + OFF
For 4p t <sub>g</sub> (S) Ground Fault Pickup Time	0.4-1 sec in steps of 0.1sec												

Setting Parameters		Electronic Type With LCD															
Frame Size	iSGM6E-630A								iSGM6E-800A		iSGM6E-1000A			iSGM6E-1600A			
Rated current In(A)	250	300	315	320	400	500	600	630	630	800	630	800	1000	1000	1250	1600	
Ir(A) Long Delay Current Setting	100-250A in steps of 1A	120-300A in steps of 1A	126-315A in steps of 1A	128-320A in steps of 1A	160-400A in steps of 1A	200-500A in steps of 1A	240-600A in steps of 1A	252-630A in steps of 1A	252-630A in steps of 1A	320-800A in steps of 1A	252-630A in steps of 1A	320-800A in steps of 1A	400-1000A in steps of 1A	400-1000A in steps of 1A	500-1250A in steps of 1A	630-1600A in steps of 1A	
tr(S) Long Delay Time	12-150 sec in steps of 1 sec+OFF																
Isd(A) Short Circuit Protection Of Low Level Faults	200-3000A in steps of 1A	240-3600A in steps of 1A	252-3780A in steps of 1A	256-3840A in steps of 1A	320-4800A in steps of 1A	400-6000A in steps of 1A	480-7200A in steps of 1A	504-7560A in steps of 1A	504-5670A in steps of 1A	640-7200A in steps of 1A	504-5670A in steps of 1A	640-7200A in steps of 1A	800-10000A in steps of 1A	800-10000A in steps of 1A	1000-12500A in steps of 1A	1260-16000A in steps of 1A	
tsd (S) short time	0.06-1 sec in steps of 0.01 sec+OFF																
Ii(A) Short Circuit Protection Of High level Faults	400-3500A in steps of 1A + OFF	480-4200A in steps of 1A + OFF	504-4410A in steps of 1A + OFF	512-4480A in steps of 1A + OFF	640-5600A in steps of 1A + OFF	800-7000A in steps of 1A + OFF	960-8400A in steps of 1A + OFF	1008-8820A in steps of 1A + OFF	1008-8820A in steps of 1A + OFF	1280-9600A in steps of 1A + OFF	1008-8820A in steps of 1A + OFF	1280-9600A in steps of 1A + OFF	1600-12000A in steps of 1A + OFF	1600-12000A in steps of 1A + OFF	2000-15000A in steps of 1A + OFF	2520-19200A in steps of 1A + OFF	
Ip(A) Pre Trip Alarm Setting Multiple	70-250A in steps of 1A	84-300A in steps of 1A	88.2-315A in steps of 1A	89.6-320A in steps of 1A	112-400A in steps of 1A	140-500A in steps of 1A	168-600A in steps of 1A	176.4-630A in steps of 1A	176.4-630A in steps of 1A	224-800A in steps of 1A	176.4-630A in steps of 1A	224-800A in steps of 1A	280-1000A in steps of 1A	360-900A in steps of 1A	450-1125A in steps of 1A	567-1440A in steps of 1A	
For 4p Ig(A) Ground Fault Pickup Current	50-250A in steps of 1A + OFF	60-300A in steps of 1A + OFF	63-315A in steps of 1A + OFF	64-320A in steps of 1A + OFF	80-400A in steps of 1A + OFF	100-500A in steps of 1A + OFF	120-600A in steps of 1A + OFF	126-630A in steps of 1A + OFF	126-630A in steps of 1A + OFF	160-800A in steps of 1A + OFF	126-630A in steps of 1A + OFF	320-800A in steps of 1A + OFF	400-1000A in steps of 1A + OFF	200-1000A in steps of 1A + OFF	250-1250A in steps of 1A + OFF	320-1600A in steps of 1A + OFF	
For 4p tg(S) Ground Fault Pickup Time	0.4-1 sec in steps of 0.1sec																

# MCCB With ELCB Type

SGM6L Moulded Case  
Circuit Breaker



## Ratings And Specifications MCCB With ELCB Type

Frame Size												
Model	SGM6L-125	SGM6L-160	SGM6L-250	SGM6L-400	SGM6L-630							
Number of poles	3P+N											
Rated current(A) In	32,40,50,63 70,80,100,125	63,70,80,100 125,140,160	100,125,140, 160,180,200,225,250	225,250,315, 350,400	400,500,630							
Standard	IEC60947-2											
Reference temperature	40°C/50°C/55°C											
Rated insulation voltage Ui (V)	690	1000										
Rated impulse withstand voltage Uimp (kV)	6	8										
Breaking capacity level	L	L	M	L	M	L	M	H	L	M	H	
Rated ultimate short-circuit breaking capacity Icu(kA)	10	36	50	36	50	50	65	85	50	65	85	
Rated service short-circuit breaking capacity Ics(kA)	7.5	25	36	25	36	36	42	65	36	42	65	
Mechanical Endurance	10000	for 63A-100A	for 125-160A	for 100A	for 125-250A	for 225-315A	for 350-400A					
Electrical Endurance	1500	8500 1500	7000 1000	8500 1500	7000 1000	7000 1000	4000 1000	4000 1000				
Rated residual operating current I <sub>Δn</sub> (mA)												
Without time delay	50/100/300/500/1000	100/300/500/1000/3000	100/300/500/1000/3000	100/300/500/1000/3000								
With time delay	100/300/500/1000	100/300/500/1000	100/300/500/1000	100/300/500/1000								
Rated residual non-operating current	1/2 I <sub>Δn</sub>											
Breaking time at a residual current	2I <sub>Δn</sub>			5I <sub>Δn</sub>			10I <sub>Δn</sub>					
Without time delay	0.15			0.04								
With time delay	0.4/1											
Selectivity category	A*											
Installation	Straight extension bars(FB) Spread extension bars(FB) Rear connection(RC) Phase barrier											

A\* type means neutral line only with isolation function;

## Product Dimension Drawing MCCB With ELCB Type

**SGM6L**  
125,160,250,400,630

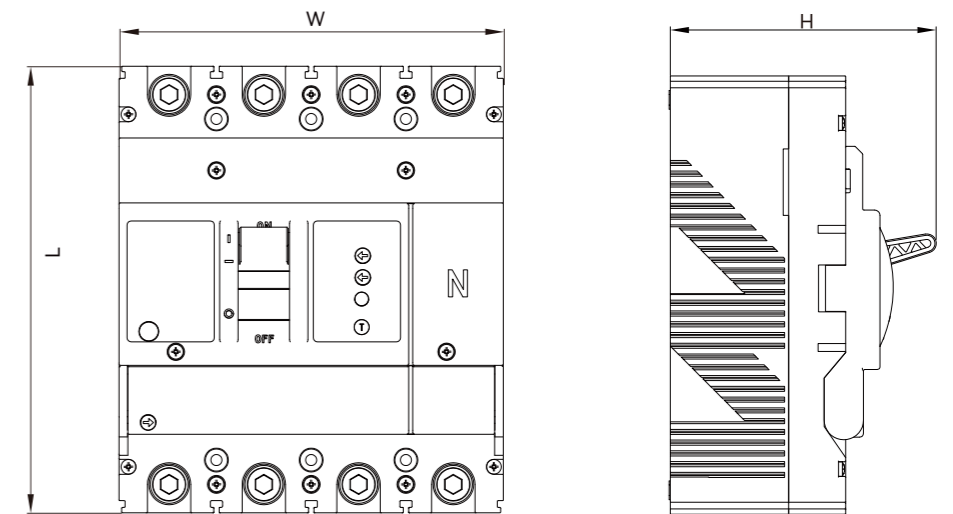

SGM6L Dimensions mm(L×W×H)						
Frame Size	125	160	250	400	630	
3P+N	Length	132.8	155	165	267	267
	Width	100	122	142	197	197
	Height	81	95.3	102	150	150

# MCCB Accessories

Internal Accessories  
External Accessories

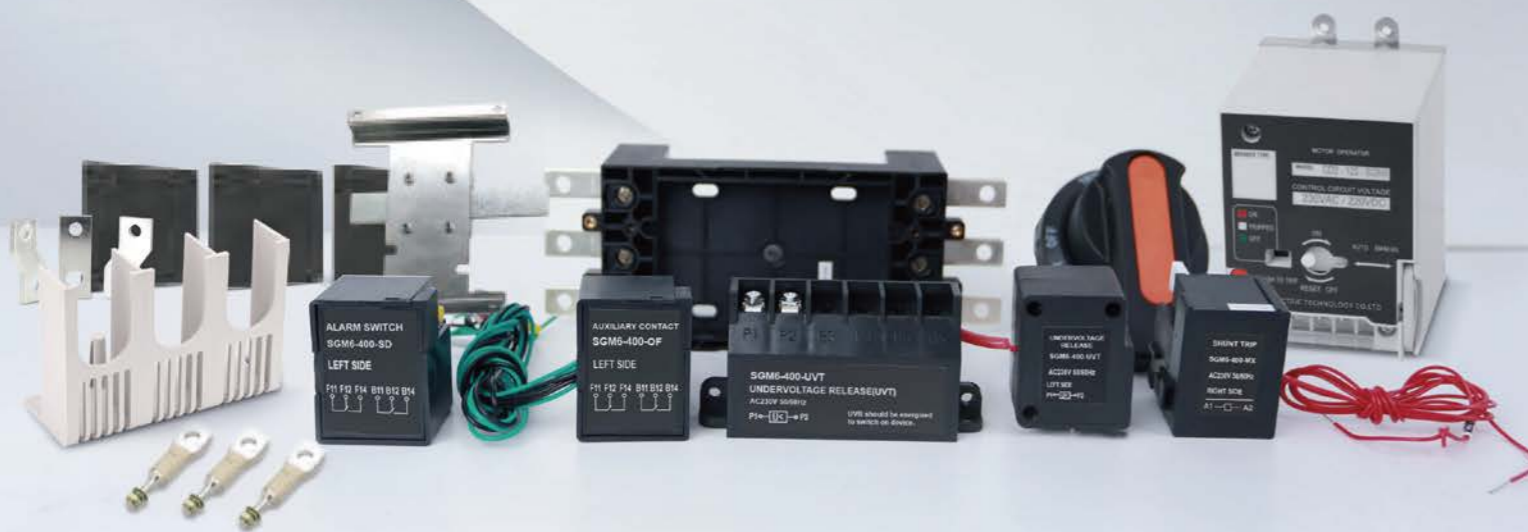

## Accessories

## Overview of Accessories

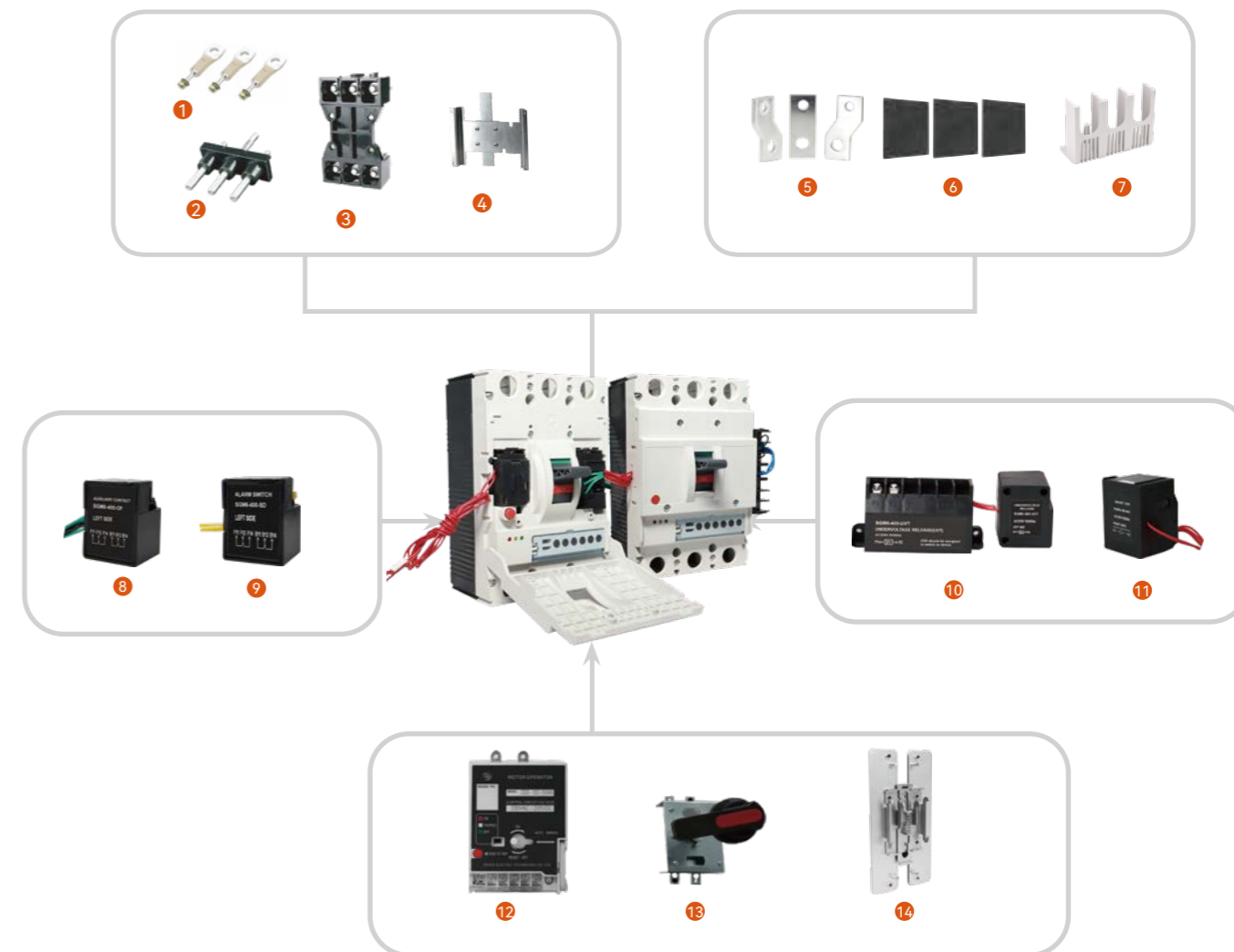

- |   |                          |    |                                   |
|---|--------------------------|----|-----------------------------------|
| 1 | Fixed rear connection    | 8  | Auxiliary contact                 |
| 2 | Plug-in rear connection  | 9  | Alarm contact                     |
| 3 | Plug-in front connection | 10 | Under-voltage release             |
| 4 | Mechanical interlock     | 11 | Shunt release                     |
| 5 | Spreader links           | 12 | Motor                             |
| 6 | Interphase barriers      | 13 | Rotary handle operating mechanism |
| 7 | Terminal cover           | 14 | DIN Rail adaptor                  |

## Internal Accessories

### ■ Auxiliary contact with Wire

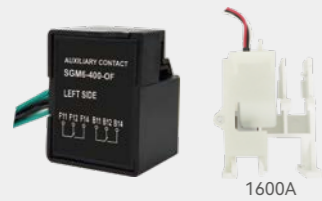

An accessory that is connected to the auxiliary contact of the switching device to indicate whether the circuit breaker is in the ON position or not.

#### Electrical wiring diagram

Accessory name	ON	OFF/TRIP
Auxiliary		

#### Electrical parameters

Conventional Thermal Current	3A		
Use category		AC 15	DC 13
Working electricity 50Hz	AC 400V	0.3A	
	DC 220V		0.15A

Auxiliary contact	Frame size	Contact	Left	Right
	SGM6-125	1NC+1NO	SGM6125OF11L	SGM6125OF11R
		2NC+2NO	SGM6125OF21L	SGM6125OF21R
	SGM6-160	1NC+1NO	SGM6160OF11L	SGM6160OF11R
		2NC+2NO	SGM6160OF21L	SGM6160OF21R
	SGM6-250	1NC+1NO	SGM6250OF11L	SGM6250OF11R
		2NC+2NO	SGM6250OF21L	SGM6250OF21R
SGM6-400/630/800/1000	1NC+1NO	SGM6630OF11L	SGM6630OF11R	
	2NC+2NO	SGM6630OF21L	SGM6630OF21R	
	SGM6-1600	1NC+1NO	SGM61600OF11L	SGM61600OF11R
		2NC+2NO	SGM61600OF21L	SGM61600OF21R

## Internal Accessories

### ■ Shunt release with Wire



- The shunt release shall reliably trip the circuit breaker at the voltage between 70% and 110% of the rated control power voltage  $U_e$ .
- The circuit breaker shall be reset on the site after tripping through the shunt release.

#### Electrical wiring diagram

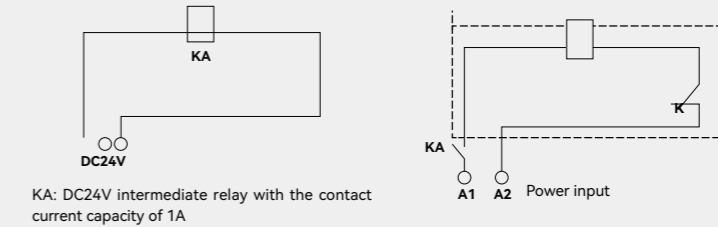

#### Electrical parameters

Frame size	Shunt release power loss(W)		
	AC400V	AC230V	DC24V
SGM6-125	152	161	180
SGM6-160	116	225	165
SGM6-250	220	161	108
SGM6-400/630/800/1000	108	179	98
SGM6-1600	200	150	108

Shunt release	Frame size	Voltage	Left	Right
	SGM6-125	AC230V	SGM6125MXAC2L	SGM6125MXAC2R
		AC400V	SGM6125MXAC3L	SGM6125MXAC3R
		DC110V	SGM6125MXDC1L	SGM6125MXDC1R
		DC220V	SGM6125MXDC2L	SGM6125MXDC2R
	SGM6-160	DC24V	SGM6125MXDC3L	SGM6125MXDC3R
		AC230V	SGM6160MXAC2L	SGM6160MXAC2R
		AC400V	SGM6160MXAC3L	SGM6160MXAC3R
		DC110V	SGM6160MXDC1L	SGM6160MXDC1R
	SGM6-250	DC220V	SGM6160MXDC2L	SGM6160MXDC2R
		DC24V	SGM6160MXDC3L	SGM6160MXDC3R
		AC230V	SGM6250MXAC2L	SGM6250MXAC2R
		AC400V	SGM6250MXAC3L	SGM6250MXAC3R
SGM6-400/630/800/1000	DC110V	SGM6250MXDC1L	SGM6250MXDC1R	
	DC220V	SGM6250MXDC2L	SGM6250MXDC2R	
	DC24V	SGM6250MXDC3L	SGM6250MXDC3R	
	AC230V	SGM6630MXAC2L	SGM6630MXAC2R	
SGM6-1600	AC400V	SGM6630MXAC3L	SGM6630MXAC3R	
	DC110V	SGM6630MXDC1L	SGM6630MXDC1R	
	DC220V	SGM6630MXDC2L	SGM6630MXDC2R	
	DC24V	SGM6630MXDC3L	SGM6630MXDC3R	

## Internal Accessories

### Alarm contact with Wire



An accessory used to indicate whether the circuit breaker has tripped. When the alarm contact indicates that the circuit breaker is at Trip status, there are the following five possibilities.

- Overload or short circuit fault.
- Residual current fault.
- Shunt release action.
- Line fault and undervoltage release action.

#### Electrical wiring diagram

Accessory name	ON/OFF	TRIP
Alarm		

#### Electrical parameters

Conventional Thermal Current	3A		
Use category		AC 15	DC 13
Working electricity 50Hz	AC 400V	0.3A	
	DC 220V		0.15A

Alarm contact	Frame size	Left	Right
	SGM6-125	SGM6125SD1L	SGM6125SD1R
	SGM6-160	SGM6160SD1L	SGM6160SD1R
	SGM6-250	SGM6250SD1L	SGM6250SD1R
	SGM6-400/630/800/1000	SGM6630SD1L	SGM6630SD1R
	SGM6-1600	SGM61600SD1L	SGM61600SD1R

### Auxiliary + Alarm with Wire

Auxiliary + Alarm	Frame size	Left	Right
	SGM6-125	SGM6125OFSD1L	SGM6125OFSD1R
	SGM6-160	SGM6160OFSD1L	SGM6160OFSD1R
	SGM6-250	SGM6250OFSD1L	SGM6250OFSD1R
	SGM6-400/630/800/1000	SGM6630OFSD1L	SGM6630OFSD1R

## Internal Accessories

### Under voltage release with Terminal



- The undervoltage release shall reliably trip the circuit breaker at the voltage between 35% and 70% of the rated operational voltage;
- The undervoltage release shall ensure that the circuit breaker can be switched on at the voltage between 85% and 110% of the rated operational voltage;
- The undervoltage release shall prevent the circuit breaker from switching on when voltage is below 35% of the rated operational voltage.

#### Electric wiring diagram

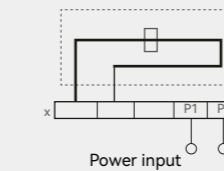

Note: X- terminal block

Note: In the dashed box, it is the wiring diagram of accessories in the circuitbreaker.

#### Electrical parameters

Frame size	Undervoltage release power loss(W)	
	AC400V	AC230V
SGM6-125	124	41
SGM6-160	4	2.4
SGM6-250	4	2.4
SGM6-400/630/800/1000	224	184
SGM6-1600	2.53	3.4

Under voltage release	Frame size	Voltage	Left	Right
	SGM6-125	AC230V	SGM6125MNAC2L	SGM6125MNAC2R
		AC400V	SGM6125MNAC3L	SGM6125MNAC3R
		DC110V	SGM6125MNDC1L	SGM6125MNDC1R
		DC220V	SGM6125MNDC2L	SGM6125MNDC2R
	SGM6-160	DC24V	SGM6125MNDC3L	SGM6125MNDC3R
		AC230V	SGM6160MNAC2L	SGM6160MNAC2R
		AC400V	SGM6160MNAC3L	SGM6160MNAC3R
		DC110V	SGM6160MNDC1L	SGM6160MNDC1R
	SGM6-250	DC220V	SGM6160MNDC2L	SGM6160MNDC2R
		DC24V	SGM6160MNDC3L	SGM6160MNDC3R
		AC230V	SGM6250MNAC2L	SGM6250MNAC2R
		AC400V	SGM6250MNAC3L	SGM6250MNAC3R
SGM6-400/630/800/1000	DC110V	SGM6250MNDC1L	SGM6250MNDC1R	
	DC220V	SGM6250MNDC2L	SGM6250MNDC2R	
	DC24V	SGM6250MNDC3L	SGM6250MNDC3R	
	AC230V	SGM6630MNAC2L	SGM6630MNAC2R	
SGM6-1600	AC400V	SGM6630MNAC3L	SGM6630MNAC3R	
	DC110V	SGM6630MNDC1L	SGM6630MNDC1R	
	DC220V	SGM6630MNDC2L	SGM6630MNDC2R	
	DC24V	SGM6630MNDC3L	SGM6630MNDC3R	

## External Accessories

### ■ Rear connection



Easy to install and connect the products in the rear connection.

Rear connection	Frame size	3P(6pcs)	4P(8pcs)
	SGM6-125	SGM6125RC3	SGM6125RC4
	SGM6-160	SGM6160RC3	SGM6160RC4
	SGM6-250	SGM6250RC3	SGM6250RC4
	SGM6-400	SGM6400RC3	SGM6400RC4
	SGM6-630	SGM6630RC3	SGM6630RC4
	SGM6-800	SGM6800RC3	SGM6800RC4
	SGM6-1000	SGM61000RC3	SGM61000RC4

### ■ Plug-in



#### Plug-in

The wiring type is divided into plug-in Rear Connection and plug-in Front Connection. The plug-in connection for the products is easy for maintenance and replacement, but plug-in and plug-out cannot be done with the electricity.

Frame size	Fixed front	Fixed rear	Plug-in front	Plug-in rear
SGM6-125	■	■	■	■
SGM6-160	■	■	■	■
SGM6-250	■	■	■	■
SGM6-400	■	■	■	■
SGM6-630	■	■	■	■
SGM6-800/1000	■	■	■	■

Plug-in	Frame size	Connection type	3P	4P
	SGM6-125	Front connection	SGM6125PF3	SGM6125PF4
		Rear connection	SGM6125PR3	SGM6125PR4
	SGM6-160	Front connection	SGM6160PF3	SGM6160PF4
		Rear connection	SGM6160PR3	SGM6160PR4
	SGM6-250	Front connection	SGM6250PF3	SGM6250PF4
		Rear connection	SGM6250PR3	SGM6250PR4
	SGM6-400	Rear connection	SGM6400PR3	SGM6400PR4
	SGM6-630	Rear connection	SGM6630PR3	SGM6630PR4
	SGM6-800	Rear connection	SGM6800PR3	SGM6800PR4
	SGM6-1000	Rear connection	SGM61000PR3	SGM61000PR4

## External Accessories

### ■ Rotary handle



#### Handle operating mechanism

The circuit breaker can be operated by the rotation of the handle and the ergonomically designed rotation handle makes the operation of the circuit breaker more flexible.

#### User visualization information/settings:

- 3 position indications: OFF, ON and TRIP
- The circuit breaker cannot be switched on when the door is open
- The door cannot be opened when the circuit breaker is switched on
- The axial length of the extended handle can be custom made according to the distance from the back of the circuit breaker to the door.

Rotary handle	Frame size	Handle shape	Extended (Default 150mm)
	SGM6-125	Round	SGM6125HL1
	SGM6-160	Round	SGM6160HL1
	SGM6-250	Round	SGM6250HL1
	SGM6-400	Round	SGM6400HL1
	SGM6-630	Round	SGM6630HL1
	SGM6-800/1000	Round	SGM6800HL1

### ■ DIN Rail adaptor



It is an adapter plate that allows MCCB mounting on a DIN rail.

DIN Rail adaptor	Frame size	3P/4P
	SGM6-125	SGM6125DR3
	SGM6-160	SGM6160DR3
	SGM6-250	SGM6250DR3

### ■ Mechanical interlock

Mechanical interlock is intended to prohibit both power sources from being simultaneously connected to the load. The interlocking system disables one circuit breaker by mechanically preventing handle movement from the Off position while the other circuit breaker is in the On position.

Mechanical interlock	Frame size	3P	4P
	SGM6-125	SGM6125MI3	SGM6125MI4
	SGM6-160	SGM6160MI3	SGM6160MI4
	SGM6-250	SGM6250MI3	SGM6250MI4
	SGM6-400	SGM6400MI3	SGM6400MI4
	SGM6-630	SGM6630MI3	SGM6630MI4
	SGM6-800/1000	SGM6800MI3	SGM6800MI4

## External Accessories

### Terminal cover



Protection Degree: IP40  
Protect from being contacted with main circuit.

Terminal cover	Frame size	3P(2pcs)	4P(2pcs)
	SGM6-125	SGM6125TC3	SGM6125TC4
	SGM6-160	SGM6160TC3	SGM6160TC4
	SGM6-250	SGM6250TC3	SGM6250TC4
	SGM6-400	SGM6400TC3	SGM6400TC4
	SGM6-630	SGM6630TC3	SGM6630TC4

### Motor



- Apply to remote electric connection, disconnection and re-trip of the circuit breaker and the automation control occasions.
- Rated voltage of electric operating mechanism: AC400V;AC230V/DC220V;AC/DC110V;DC24V
- Operating voltage range of electric operating mechanism: 85%-110% Ue.

Electrical wiring diagram

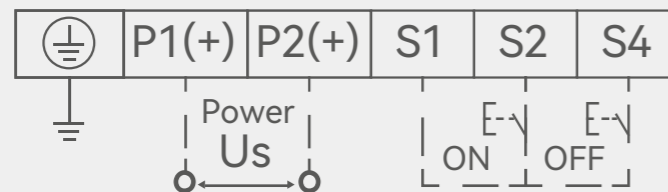

- When operating manually, operate 180° clockwise and do not operate counter clockwise.
- Withstand voltage test: it should be between the incoming terminals P1 and P2 (excluding S1, S2 and S4) of the power supply and the installation screws of electric operation that can withstand 50Hz AC, power Frequency withstand voltage test of 1890V (withstand voltage test is prohibited when rated voltage is DC24V).
- P1 and P2 are forbidden to be connected to S1, S2 and S4 during electrical operation.

#### Electrical parameters

Frame size	IP degree	Current	Voltage	Switch on/off time	Electric life
SGM6-125	20	$\leq 0.5$ DC24V $\leq 3$	AC110V/DC110V AC230V/DC220V AC400V DC24V	$\leq 0.7$	10000
SGM6-160	20	$\leq 0.8$ DC24V $\leq 3$		$\leq 0.7$	10000
SGM6-250	20	$\leq 0.8$ DC24V $\leq 3$		$\leq 0.7$	10000
SGM6-400	20	$\leq 1$ DC24V $\leq 6$		$\leq 1$	5000
SGM6-630	20	$\leq 1$ DC24V $\leq 6$		$\leq 1$	5000
SGM6-800/1000	20	$\leq 1$ DC24V $\leq 6$		$\leq 1$	5000

## External Accessories

Motor	Frame size	AC230V	AC400V	DC110V	DC220V	DC24V
	SGM6-125	SGM6125MAC2	SGM6125MAC3	SGM6125MDC1	SGM6125MDC2	SGM6125MDC3
	SGM6-160	SGM6160MAC2	SGM6160MAC3	SGM6160MDC1	SGM6160MDC2	SGM6160MDC3
	SGM6-250	SGM6250MAC2	SGM6250MAC3	SGM6250MDC1	SGM6250MDC2	SGM6250MDC3
	SGM6-400	SGM6400MAC2	SGM6400MAC3	SGM6400MDC1	SGM6400MDC2	SGM6400MDC3
	SGM6-630	SGM6630MAC2	SGM6630MAC3	SGM6630MDC1	SGM6630MDC2	SGM6630MDC3
	SGM6-800/1000	SGM6800MAC2	SGM6800MAC3	SGM6800MDC1	SGM6800MDC2	SGM6800MDC3

### Spreader links



The spreader links are connected to the terminal of the circuit breaker, in order to provide many other wiring schemes in the limited space:

- Direct spreader links
- Spreader link with inter-electrode distance

The busbar and extension terminal can be connected to the inlet or outlet terminal of the circuit breaker.

Spreader links	Frame size	3P(3pcs)	4P(4pcs)
	SGM6-125	SGM6125C3	SGM6125C4
	SGM6-160	SGM6160C3	SGM6160C4
	SGM6-250	SGM6250C3	SGM6250C4
	SGM6-400	SGM6400C3	SGM6400C4
	SGM6-630	SGM6630C3	SGM6630C4
	SGM6-800	SGM6800C3	SGM6800C4
	SGM6-1000	SGM61000C3	SGM61000C4

### Interphase barriers



The interphase barriers can enhance the insulating performances between phase and phases. They can be installed from the product front even though the products had mounted. Interphase barriers will be offered by standard, 3P product(4pcs), 4P product(6pcs).

Interphase barriers	Frame size	3P(2pcs)	4P(3pcs)
	SGM6-125	SGM6125IB3	SGM6125IB4
	SGM6-160	SGM6160IB3	SGM6160IB4
	SGM6-250	SGM6250IB3	SGM6250IB4
	SGM6-400/630	SGM6630IB3	SGM6630IB4
	SGM6-800/1000	SGM6800IB3	SGM6800IB4

## MCCB With Spreader Link Dimensions

### ■ Front connection

Note: All dimensions are in mm

**SGM6/6s-125A 3 POLES & 4 POLES**

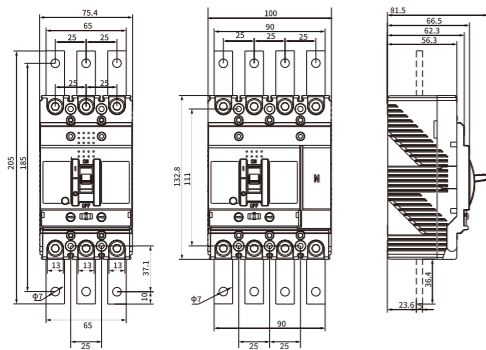

**SGM6/6s/6sm/6E-160A 3 POLES & 4 POLES**

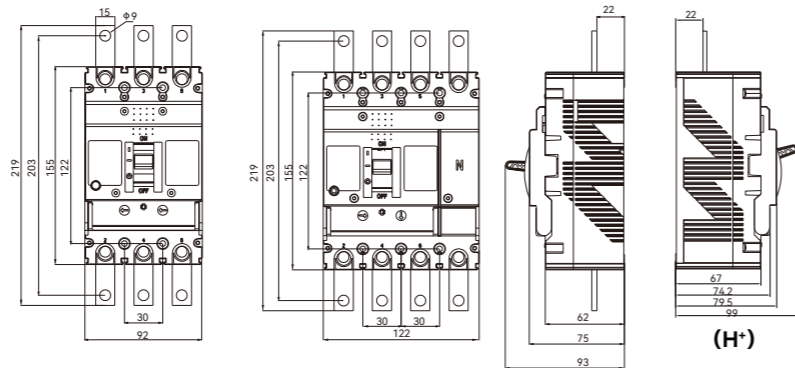

**SGM6/6s/6sm/6E-250A 3 POLES & 4 POLES**

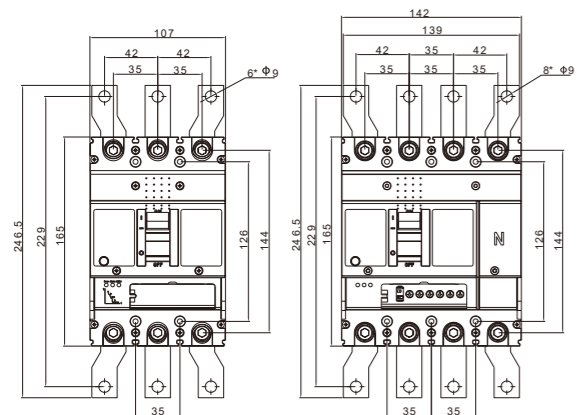

**SGM6/6s/6sm-250A(H\*) 3 POLES & 4 POLES**

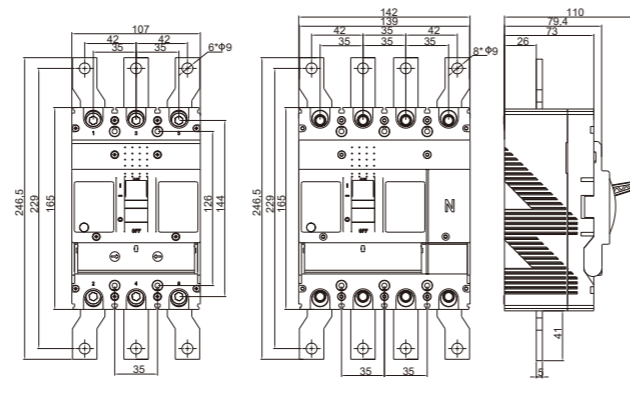

**SGM6/6s/6sm/6E-400A/630A 3 POLES & 4 POLES**

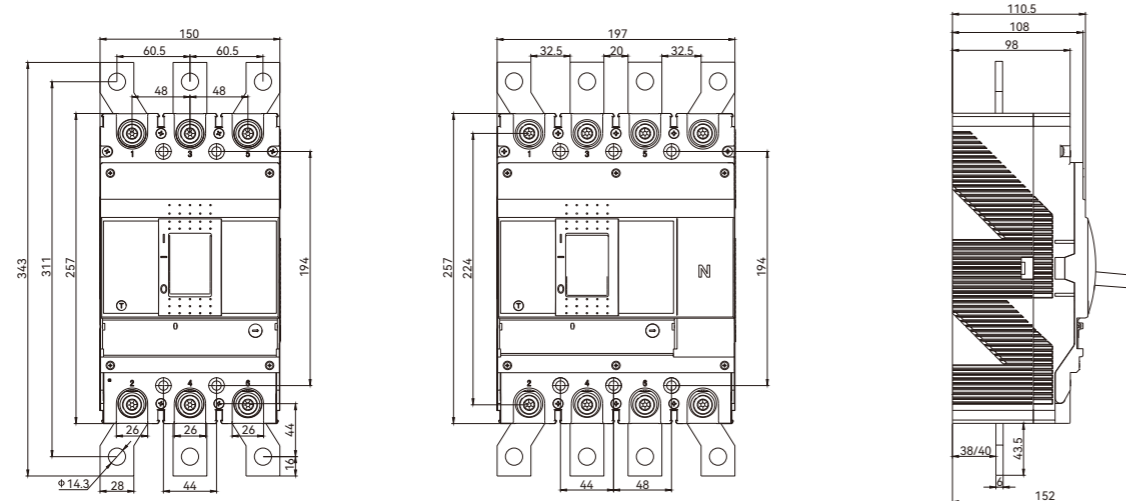

## MCCB With Spreader Link Dimensions

### ■ Front connection

Note: All dimensions are in mm

**SGM6/6s/6sm-400A(Me) 3 POLES & 4 POLES**

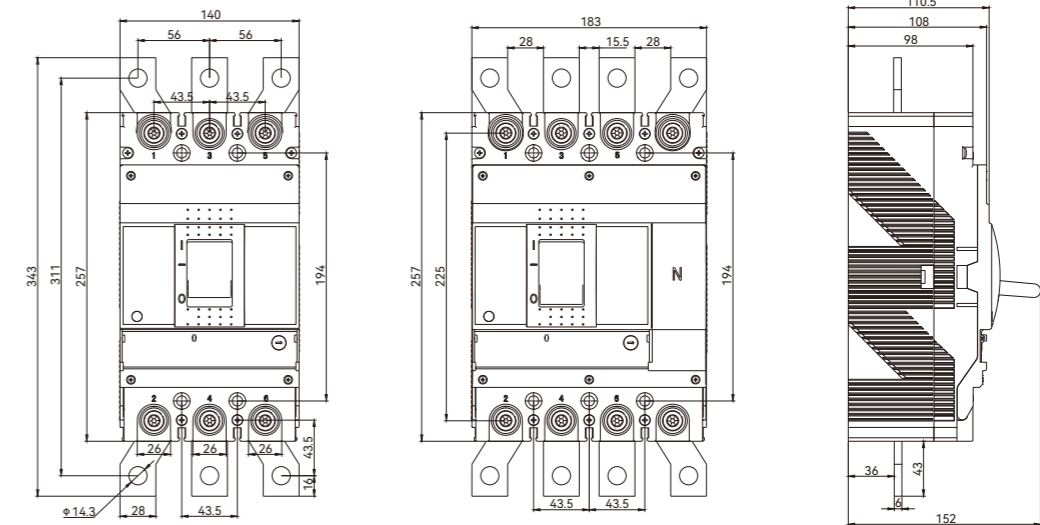

**SGM6/6s/6sm/6E-800/1000A 3 POLES & 4 POLES**

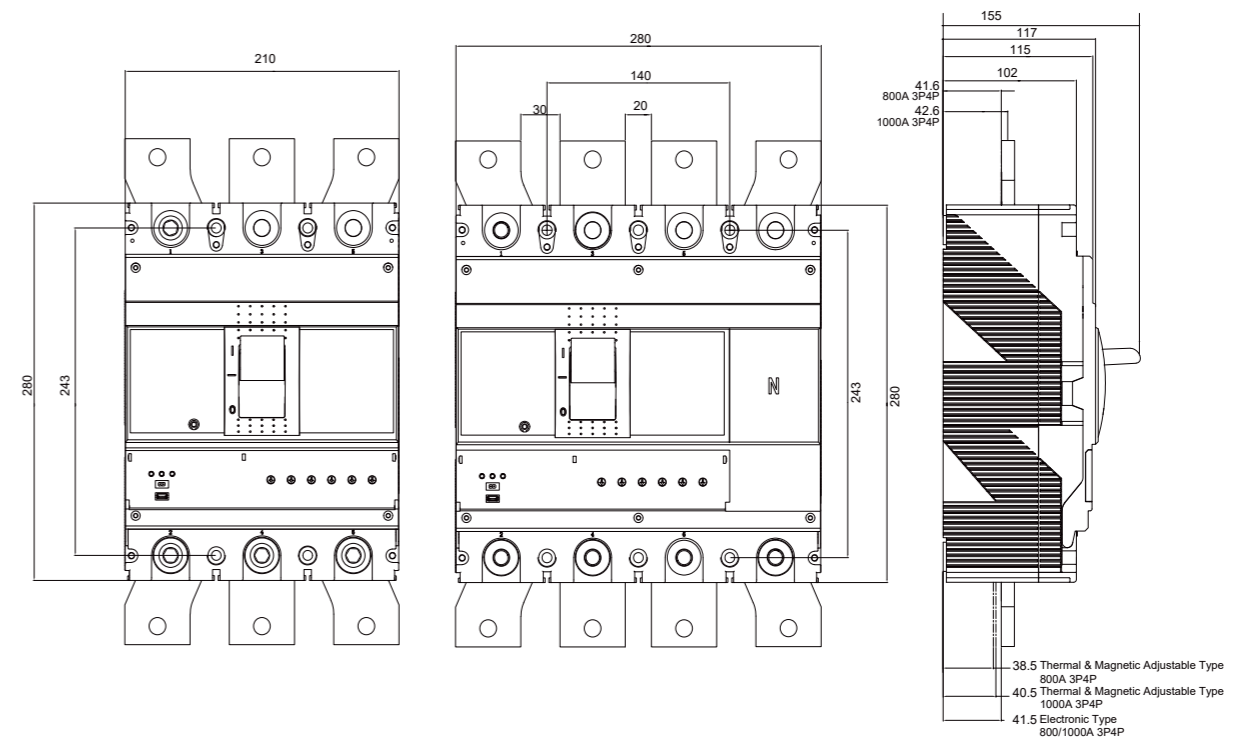

## MCCB With Spreader Link Dimensions

### Front connection

Note: All dimensions are in mm

SGM6/6s/6sm/6E-1600A 3 POLES & 4 POLES

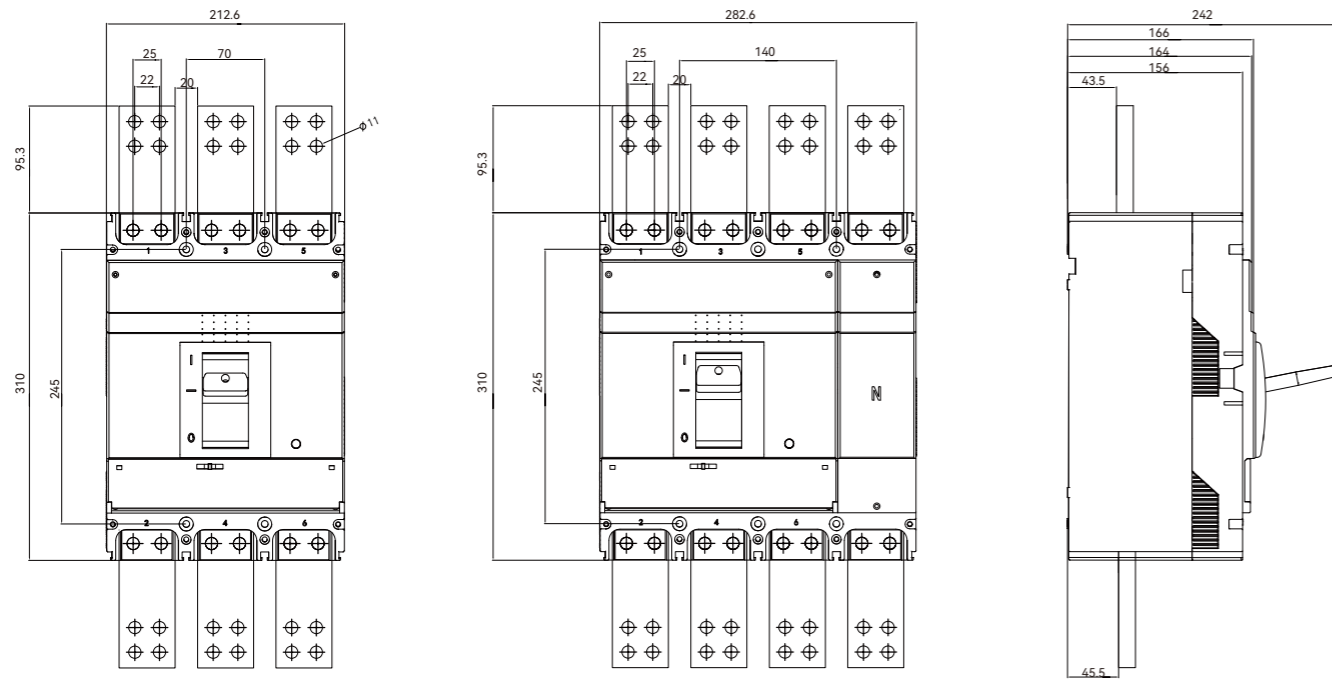

SGM6L-125A 3P+N POLES

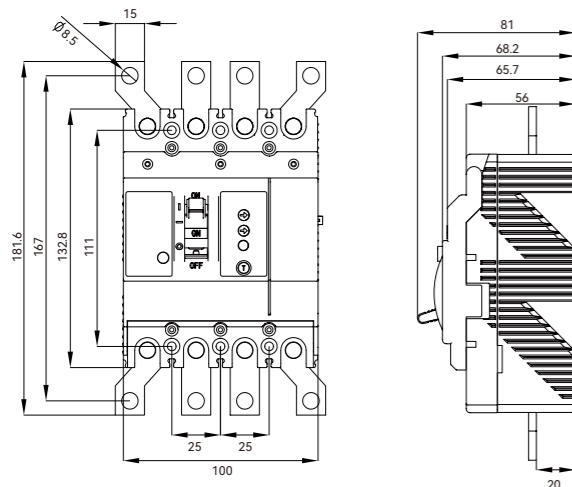

SGM6L-160A 3P+N POLES

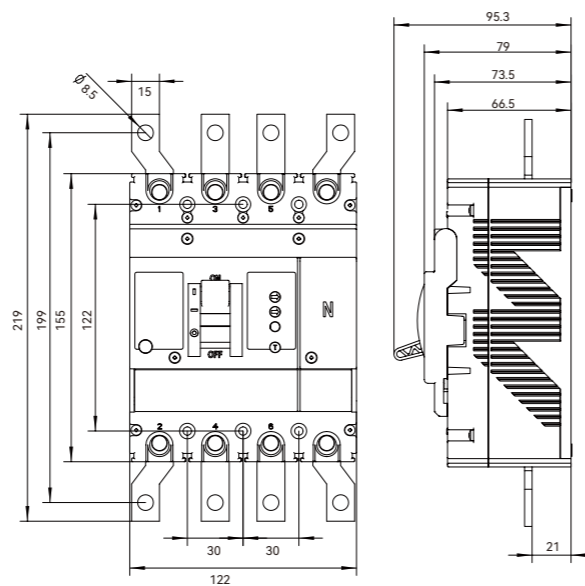

## MCCB With Spreader Link Dimensions

### Front connection

Note: All dimensions are in mm

SGM6L-250A 3P+N POLES

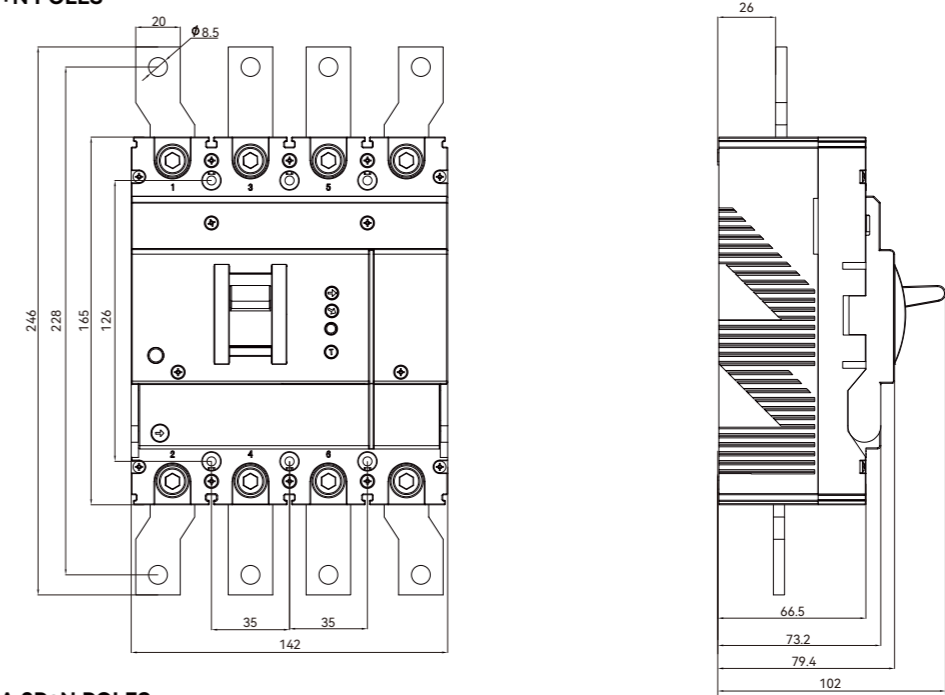

SGM6L-400/630A 3P+N POLES

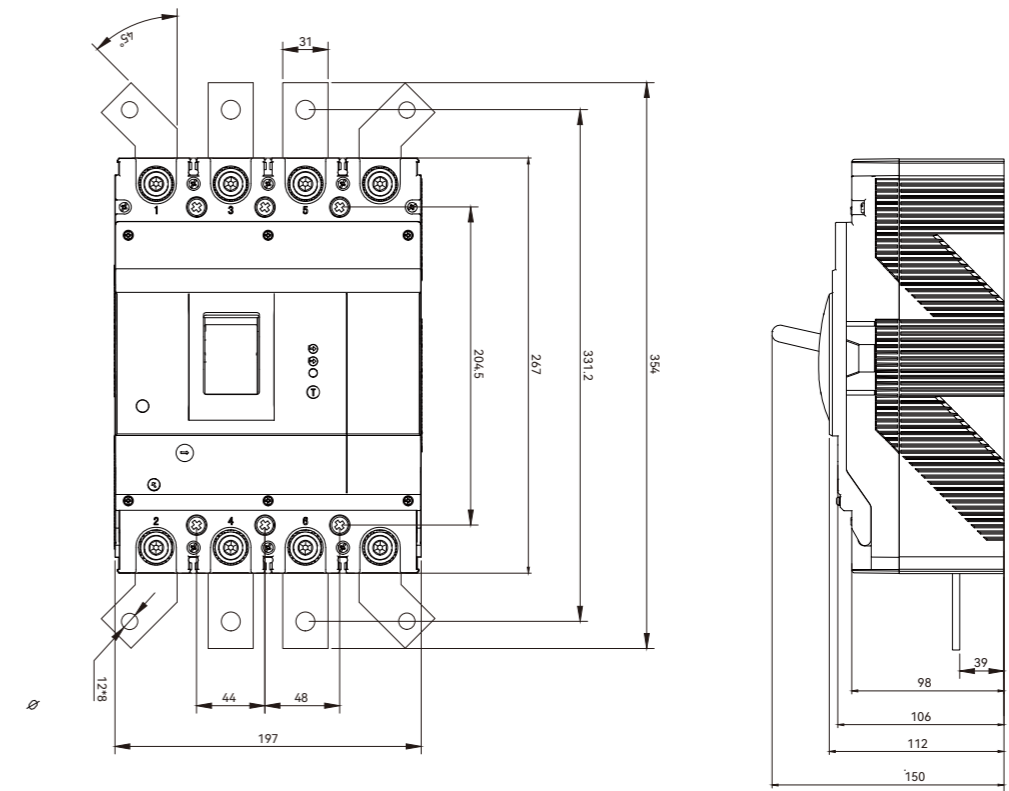

## Plug-in MCCB Mounting Dimensions

### ■ Front connection(mm)

Note:All dimensions are in mm

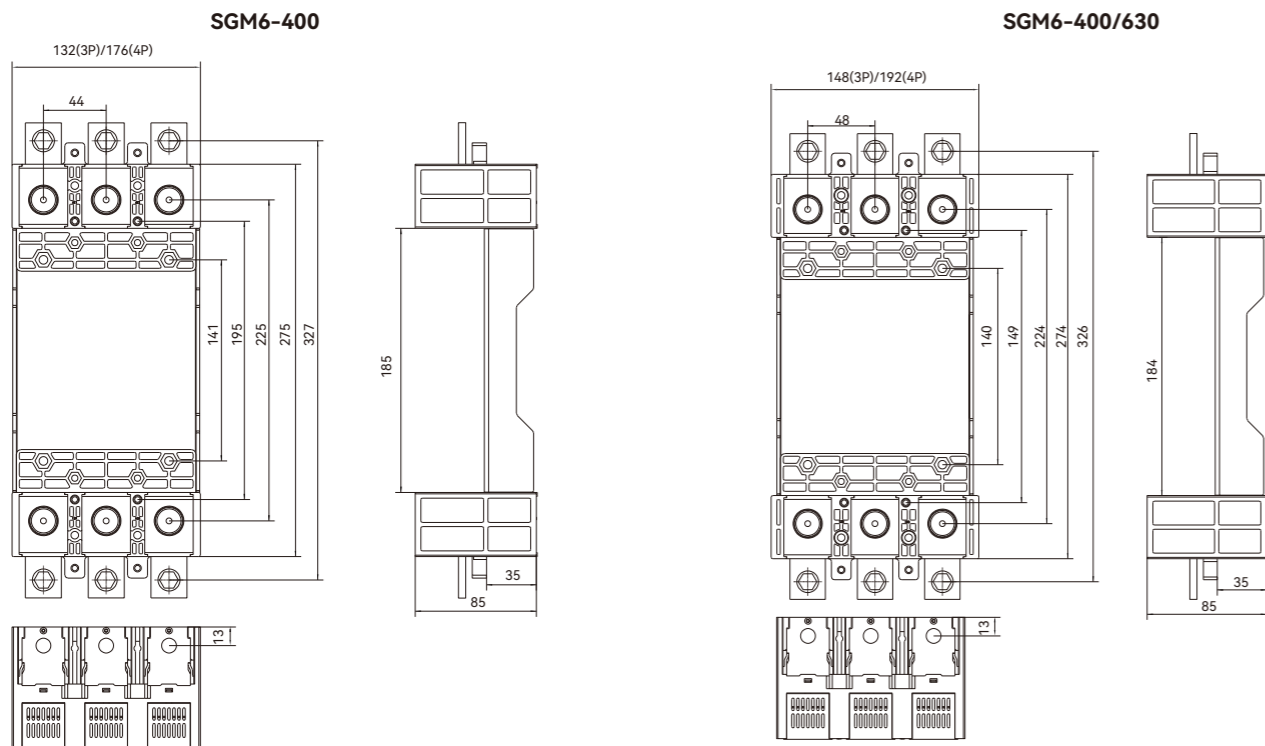
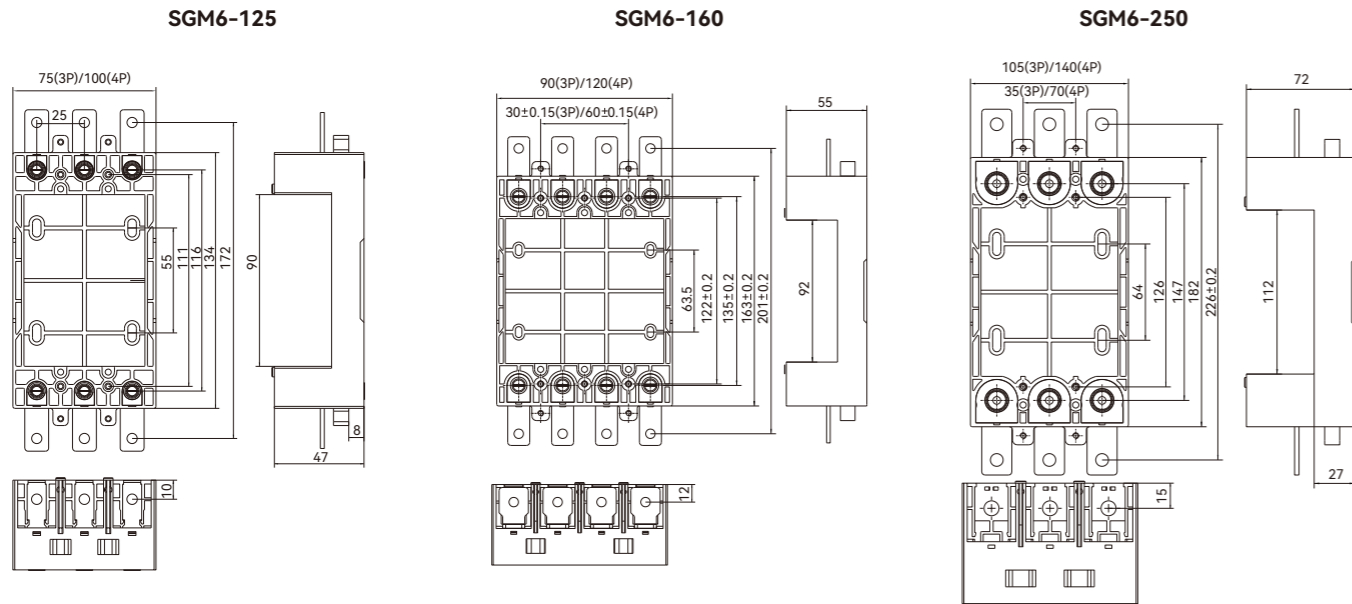

## Rotary Handle Dimensions

### ■ Mounting with MCCB dimensions(mm)

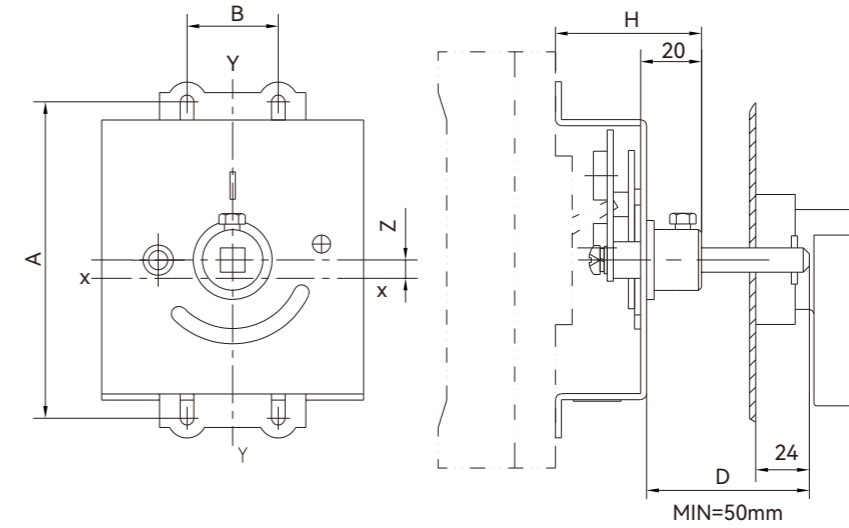

Model Number	Frame size	Installation dimensions		
		A	B	H
CS1-125/SGM6	SGM6-125	111	25	53
CS1-160/SGM6	SGM6-160	122	30	58
CS1-250/SGM6	SGM6-250	144	35	63
CS1-400/SGM6	SGM6-400/630	221.5	44	77
CS1-800/SGM6	SGM6-800/1000	245	198	

### ■ Handle and door cutting dimensions(mm)

#### Round handle dimensions

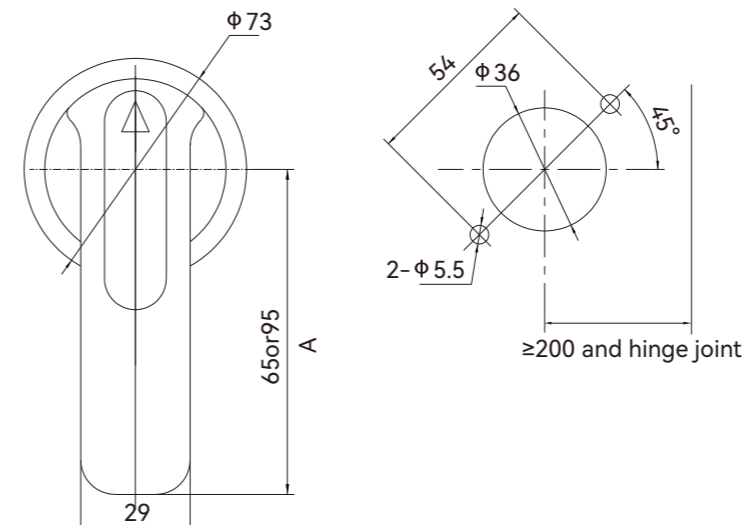

Frame size	A
SGM6-125	65/95
SGM6-160	65/95
SGM6-250	65/95
SGM6-400/630	65/95
SGM6-800/1000	65/95

## Motor Mounted with MCCB Dimensions

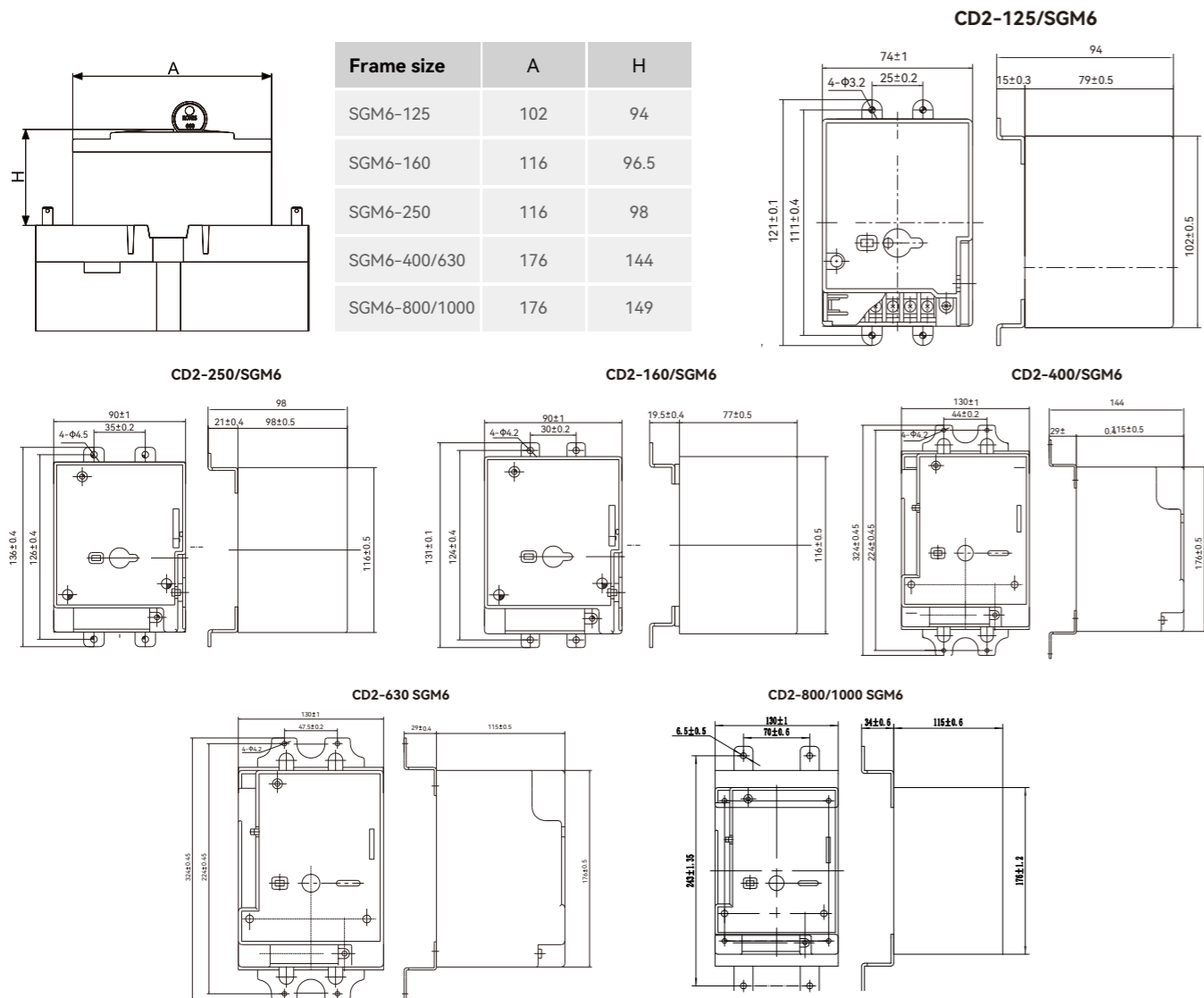

## DIN Rail adaptator with MCCB Dimensions

■ Dimensions(mm)

Frame size	SGM6-125		SGM6-160		SGM6-250	
	L1	W1	L2	W2	L3	W3
mm	111	25	122	30	126	35

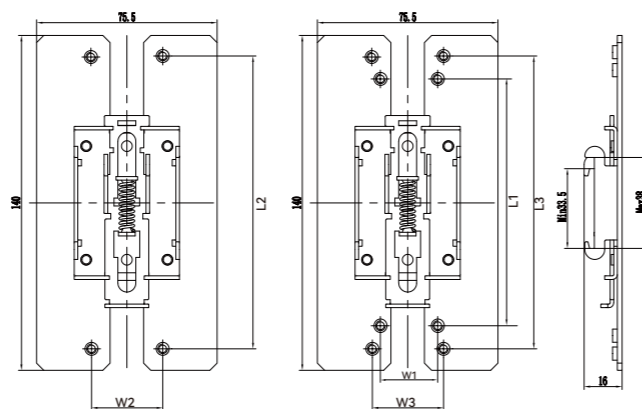

## Accessory installation and lead direction

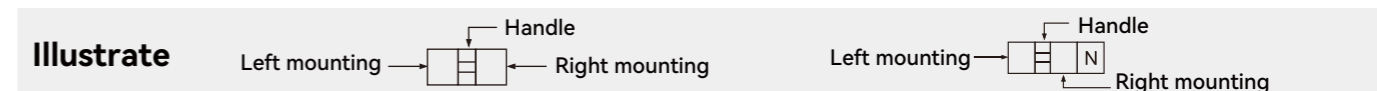

□ SD ■ OF ○ MN ● MX △ SD+OF ▲ TWO SETS OF → Lead direction

Item	Accessories	3P		4P	
		125A,160A,250A,400A,630A,800A/1000A	125A	160A,250A,400A,630A,800A/1000A	
SGM6 (125-1000A Frame)	SD	□□□	□□□	□□□□	
	MX	●●●	●●●	●●●□	
	OF	■ ■ ■	■ ■ ■	■ ■ ■ □	
	MN	○ ○ ○	○ ○ ○	○ ○ ○ □	
	SD+OF	△ △ △	△ △ △	△ △ △ □	
	TWO OF	▲ ▲ ▲	▲ ▲ ▲	▲ ▲ ▲ □	
	MX,OF	● ■ ■	● ■ ■	● ■ ■ □	
	MX,SD	● □ □	● □ □	● □ □ □	
	MX,SD+OF	● △ △	● △ △	● △ △ □	
	MX,TWO OF	● ▲ ▲	● ▲ ▲	● ▲ ▲ □	
	MX,MN	● ○ ○	● ○ ○	● ○ ○ □	
	SGM6s (125-1000A Frame)	MN,OF	○ ■ ■	○ ■ ■	○ ■ ■ □
		MN,SD	○ □ □	○ □ □	○ □ □ □
	SGM6sm (125-1000A Frame)	MN,SD+OF	○ △ △	○ △ △	○ △ △ □
		MN,TWO OF	○ ▲ ▲	○ ▲ ▲	○ ▲ ▲ □
	SGM6E (250-1000A Frame)	OF,SD	■ □ □	■ □ □	■ □ □ □
OF,MX		■ ● ●	■ ● ●	■ ● ● □	
iSGM6E (250-1000A Frame)	OF,SD+OF	■ △ △	■ △ △	■ △ △ □	
	OF,TWO OF	■ ▲ ▲	■ ▲ ▲	■ ▲ ▲ □	
DIN Rail Adaptator	OF,MN	■ ○ ○	■ ○ ○	■ ○ ○ □	
	SD,OF	□ ■ ■	□ ■ ■	□ ■ ■ □	
	SD,MX	□ ● ●	□ ● ●	□ ● ● □	
	SD,SD+OF	□ △ △	□ △ △	□ △ △ □	
	SD,TWO OF	□ ▲ ▲	□ ▲ ▲	□ ▲ ▲ □	
	SD,MN	□ ○ ○	□ ○ ○	□ ○ ○ □	
	SD+OF,OF	△ ■ ■	△ ■ ■	△ ■ ■ □	
	SD+OF,SD	△ □ □	△ □ □	△ □ □ □	
	SD+OF,MX	△ ● ●	△ ● ●	△ ● ● □	
	SD+OF,TWO OF	△ ▲ ▲	△ ▲ ▲	△ ▲ ▲ □	
	SD+OF,MN	△ ○ ○	△ ○ ○	△ ○ ○ □	
	TWO OF,OF	▲ ■ ■	▲ ■ ■	▲ ■ ■ □	
	TWO OF,SD	▲ □ □	▲ □ □	▲ □ □ □	
	TWO OF,MX	▲ ● ●	▲ ● ●	▲ ● ● □	
	TWO OF,SD+OF	▲ △ △	▲ △ △	▲ △ △ □	
	TWO OF,MN	▲ ○ ○	▲ ○ ○	▲ ○ ○ □	

Note: R2 can be installed with OF, TWO OF

## Accessory installation and lead direction

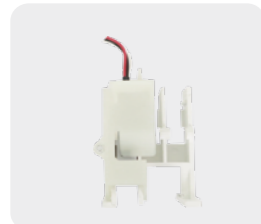

OF (Auxiliary contact)

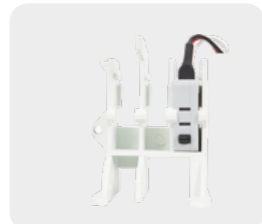

SD (Alarm switch)

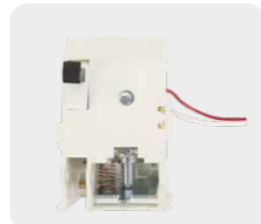

MX (Shunt trip)



MN (Under-voltage release)

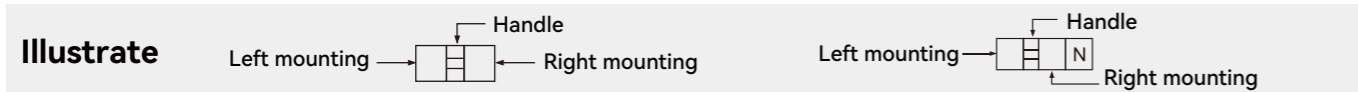

□ SD ■ OF ○ MN ● MX △ SD+OF ▲ TWO SETS OF → Lead direction

Item	Accessories	3P		4P	
		1600A	1600A	1600A	1600A
SGM6 (1600A Frame) SGM6s (1600A Frame) SGM6sm (1600A Frame) SGM6E (1600A Frame) ISGM6E (1600A Frame)	SD	□ □ □	□ □ □	□ □ □	□ □ □
	MX	● □ □	● □ □	● □ □	● □ □
	OF	■ □ □	■ □ □	■ □ □	■ □ □
	MN	○ □ □	○ □ □	○ □ □	○ □ □
	SD+OF	□ □ △	□ □ △	□ □ △	□ □ △
	TWO OF	□ □ ▲	□ □ ▲	□ □ ▲	□ □ ▲
	MX,OF	● □ ■	● □ ■	● □ ■	● □ ■
	MX,SD	● □ □	● □ □	● □ □	● □ □
	MX,SD+OF	● □ △	● □ △	● □ △	● □ △
	MX,TWO OF	● □ ▲	● □ ▲	● □ ▲	● □ ▲
	MN,OF	○ □ ■	○ □ ■	○ □ ■	○ □ ■
	MN,SD	○ □ □	○ □ □	○ □ □	○ □ □
	MN,SD+OF	○ □ △	○ □ △	○ □ △	○ □ △
	MN,TWO OF	○ □ ▲	○ □ ▲	○ □ ▲	○ □ ▲
SGM6L (1600A Frame) Note: R2 can be installed with OF, TWO OF	MX,OF	● □ ■	● □ ■	● □ ■	● □ ■
	MN,OF	○ □ ■	○ □ ■	○ □ ■	○ □ ■
	MX,SD	● □ □	● □ □	● □ □	● □ □
	MN,SD	○ □ □	○ □ □	○ □ □	○ □ □
	MX,TWO OF	● □ ▲	● □ ▲	● □ ▲	● □ ▲
	MN,TWO OF	○ □ ▲	○ □ ▲	○ □ ▲	○ □ ▲

## Accessory installation and lead direction

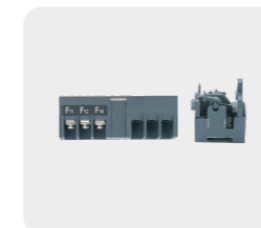

OF (Auxiliary contact)



SD (Alarm switch)

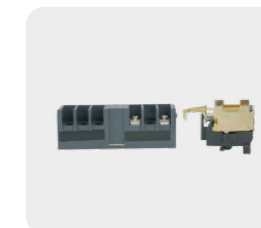

MX (Shunt trip)

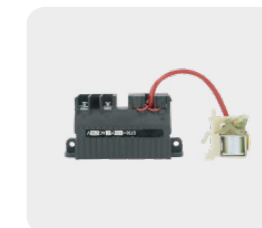

MN (Under-voltage release)

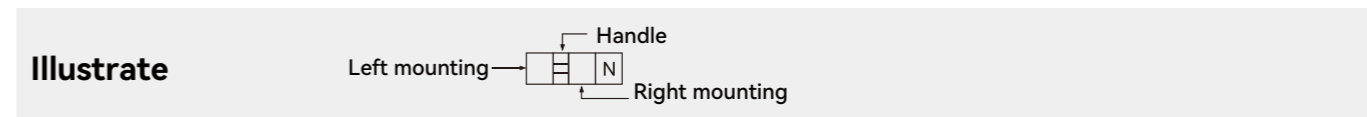

□ SD ■ OF ○ MN ● MX △ SD+OF ▲ TWO SETS OF → Lead direction

Item	Accessories	4P	
		250A,400A,630A	1600A
SGM6L	SD	□ □ □	□ □ □
	MX	● □ □	● □ □
	MN	○ □ □	○ □ □
	OF	■ □ □	■ □ □
	SD+OF	□ □ △	□ □ △

### DC Moulded Case Circuit Breaker



Frame Size	 630
Model	SGM6 DC-630
Rated current(A) In	250,320,400,450,500,630
Number of poles	2
Standard	IEC60947-2
Reference temperature	+40°C
Rated operational voltage Ue(V)	1500
Rated insulation voltage Ui (V)	1600
Rated impulse withstand voltage Uimp (kV)	12
Rated ultimate short-circuit breaking capacity Icu(kA)	1500V/20KA、(T=10ms)
Rated service short-circuit breaking capacity Ics(kA)	1500V/20KA、(T=10ms); 750V/50KA、(T=15ms)
Single pole short-circuit breaker capacity Iit(kA)	2.5
Electrical Endurance	1000
Selectivity category	A
Arcing distance	≠100
Dimensions mm(LxWxH)	98X310X130

### High Voltage AC Moulded Case Circuit Breaker

Frame Size	 320	 630	
Model	SGM6 HU-320	SGM6 HU-630	
Rated current(A) In	100,125,140 180,200,225,250,320	400,500,630	
Standard	IEC60947-2		
Reference temperature	40°C/50°C/55°C		
Rated insulation voltage Ui (V)	1250		
Rated impulse withstand voltage Uimp (kV)	8		
Rated operational voltage Ue(V)	800	1000	1140
Rated ultimate short-circuit breaking capacity Icu(kA)	36.5	20	15
Rated service short-circuit breaking capacity Ics(kA)	36.5	20	15
Mechanical Endurance	10000		7000
Electrical Endurance	1000		1000
Arcing distance	≤35		≤35
Dimensions mm(LxWxH)	200X120X108		280X150X130

Ratings And Specifications

Measuring Switch

Frame Size	 250	 250	 250
Model	SGM6RS-250	SGM6RN-250	SMG6Rse-250
Number of poles	3P		
Rated current(A) In	100,125,160,200,250	100,125,160,200,250	100,125,160,200,250
Type(Carrier )	Front plug-in		Side plug-in
Rated frequency ( f)	50Hz		
Select Category	Zero arcing Non-zero arcing		
Standard	IEC60947-2		
Reference temperature	40°C/50°C/55°C		
Rated operational voltage	AC 230V/400V		
Rated insulation voltage Ui (V)	800		
Rated impulse withstand voltage Uimp (kV)	8		
Rated ultimate short-circuit breaking capacity Icu(kA)	50	36	50
Rated service short-circuit breaking capacity Ics(kA)	36	36	36
Icu=Ics(kA)	36	36	36
Mechanical Endurance	8000	8000	8000
Electrical Endurance	2000	2000	2000

Product Dimension Drawing

Measuring Switch

■ SGM6RS-250

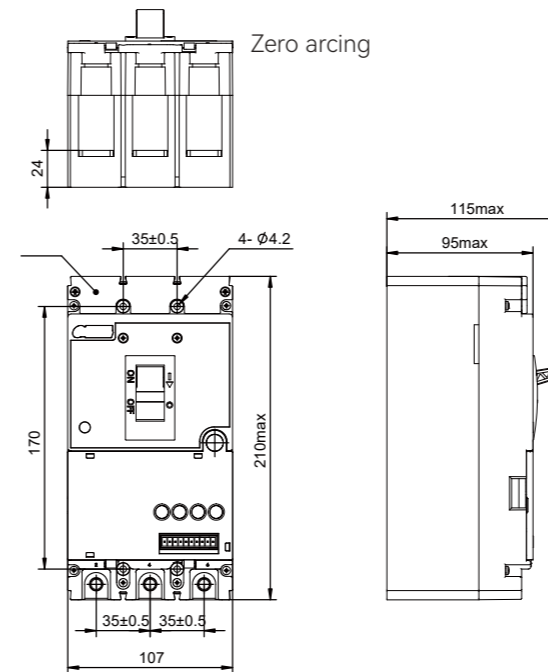

■ SGM6RS-250

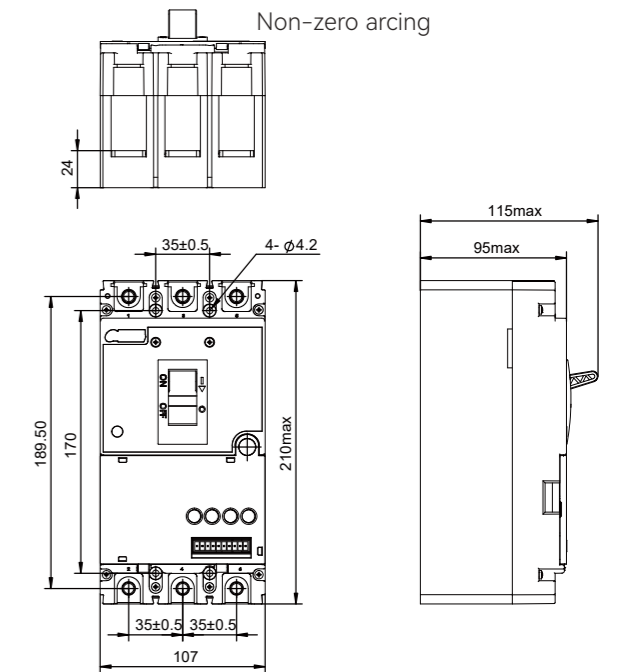

■ SGM6RN-250

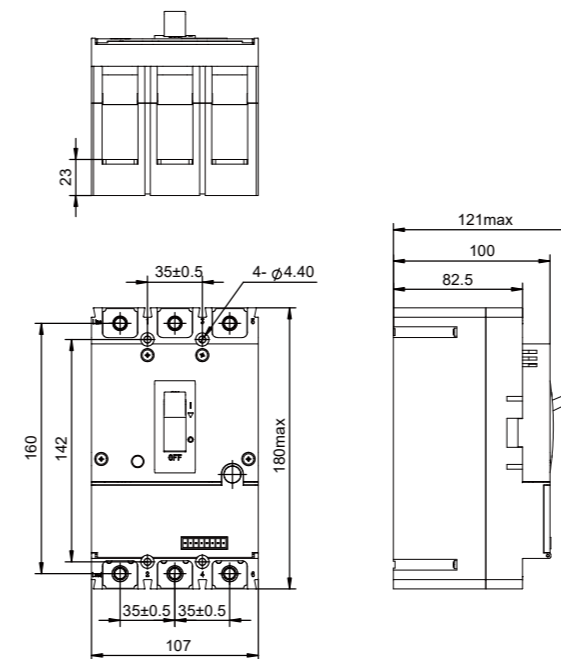

■ SMG6Rse-250

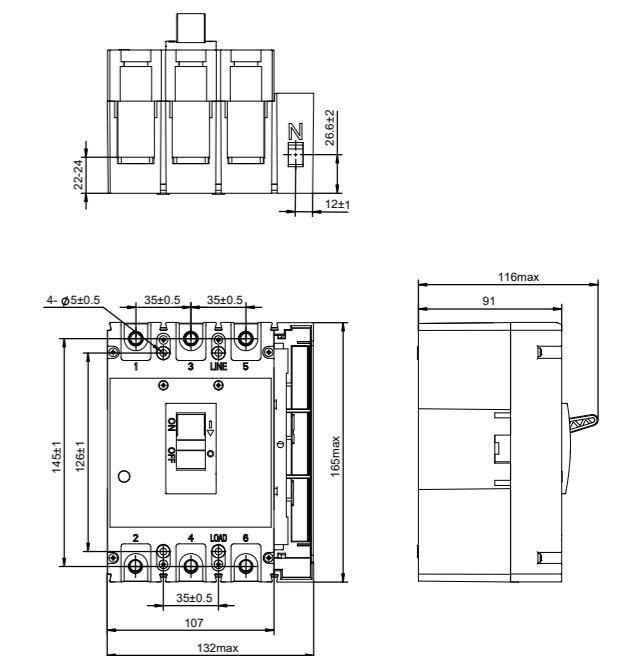

## Smart Moulded Case Circuit Breaker



SGM3EL-250CY



SGM3EL-400CY

### Product Type and Function

Function Types		Intelligent	Network
Protection Function	Over load	■	■
	Short Circuit	■	■
	Residual Current	■	■
	Auto Reclose	■	■
	Phase Loss	■	■
	Over Voltage	■	■
Measurement and Display	Under Voltage	■	■
	Residual Current Auto Test	■	■
	Three phase voltage	■	■
Characteristics Setup	Three phase current	■	■
	Rated Residual Current	■	■
	Overload Time Delay	■	■
	Short Circuit Time Delay	■	■
	Instantaneous Short Circuit	■	■
	Over voltage Value	■	■
	Under voltage Value	■	■
	Time,Date	■	■
Info Restore,Check and Display	Protection In & Out	■	■
	Residual Current Trip	■	■
Communication	RS-485	■	■
	DLT 645	■	■

## Smart Moulded Case Circuit Breaker

Specification & Type	SGM3EL-125CY	SGM3EL-250CY	SGM3EL-400/630CY	SGM3EL-800CY	
Set up value	40A,50A,63A,80A 100A,125A	100A,125A,140A 160A,180A,200A 225A,250A	200A,225A,250A 315A,350A,400A 500A 630A	400A, 500A,630A 700A,800A	
Poles	3P+N	3P+N,2P	3P+N	3P+N	
Case Current Ue( V)	AC400/50HZ		AC400/50HZ		
Rated insulation Voltage Ui ( V)	AC 800V		AC 800V		
Rated Withstand Voltage Uimp ( V)	800		8000		
Arcing Distance	≥50		≥100		
Rated short circuit breaking capacity (Icu)	50		65		
Operation short circuit breaking capacity (Ics)	35		42		
Rated Residual Short Circuit Breaking Capacity ( kA)	12.5		20		
Time delay se tup value TI	3s,4s,6s,8s,10s,12s,16s,18s, OFF				
Residual Current Trip Characteristics	AC type		AC type		
Rated Residual Trip Current I <sub>Δn</sub> (mA)	50/100/200/400/600/800 Auto trace or manual setup		100/200/300/500/800/1000 Auto trace or manual setup		
Residual Trip Time Characteristics	Time Delay / Non Time Delay				
Time Delay Limit Un- DriveTime(S)	0.06/0.1/0.2 Select:2 I <sub>an</sub>				
Auto Reclose Time ( s )	20-60				
Operation Characterises (times )	Power On	1500	1000	1000	1000
	Power Off	8500	7000	4000	4000
	Total Trips	10000	8000	5000	5000
Overload , Short circuit Characteristics	Three steps protection , electronic adjust, see more on " Protection Characteristics Instruction"				
Over Voltage Value ( V)	Setup Value(250-300)± 5%				
Under Voltage Value ( V)	Setup Value( 145~ 200)± 5%				
Connect Control Time (ms)	≤40ms				
Communication Delay Time(ms)	≤200ms				

# ATS

Automatic Transfer Switch



## ATS1 Series Automatic Transfer Switch

### Model Description

ATS	1	-	63	M	/	3P	50A
Product category	Design code	Current rank	Product code	Pole	Rated current		
CB Class Automatic Transfer Switch	1	63	X:Economical type Y:Fire type M:Mini type	3P,4P	6A-63A		

### Outline and installation dimension



ATS1-63X  
ATS1-63Y

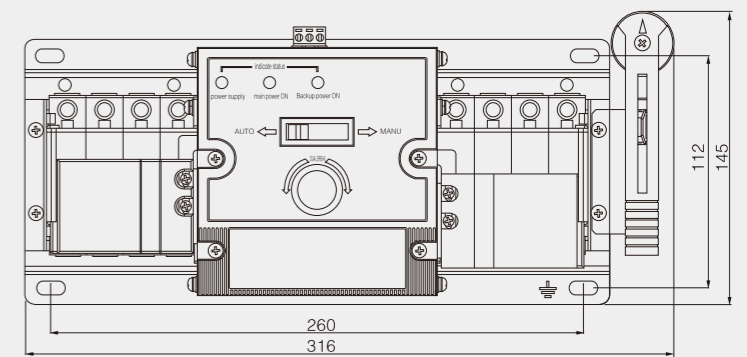

Total height: 123mm

### ATS1-63X, ATS1-63Y Series wiring diagram

#### ATS1-63X wiring diagram

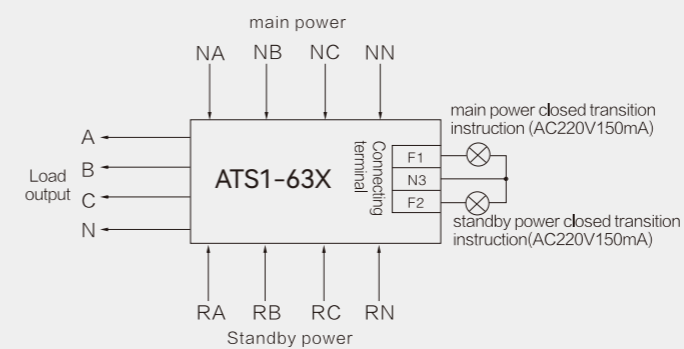

#### ATS1-63Y wiring diagram

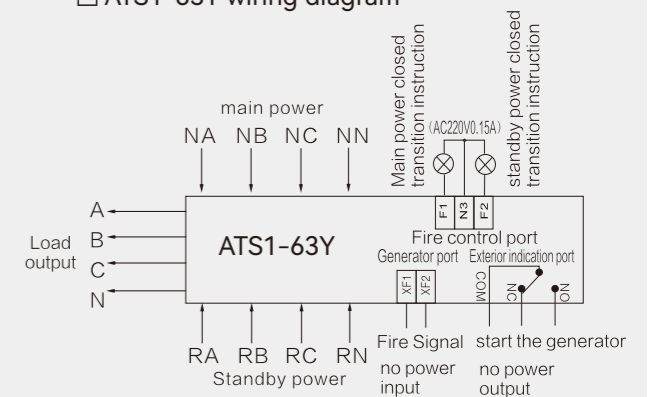

## ATS1 Series Automatic Transfer Switch

### Outline and installation dimension

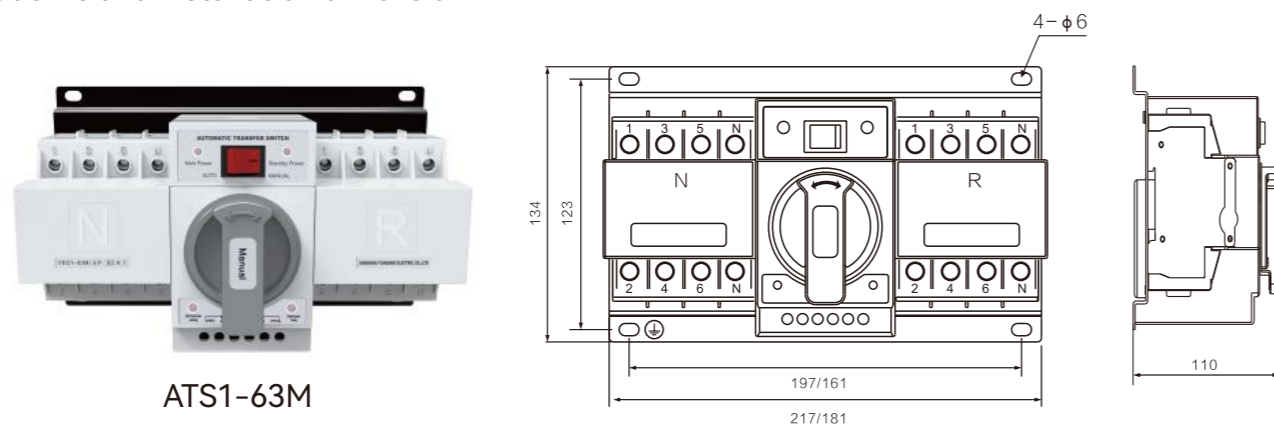

ATS1-63M

### ATS1-63M Series wiring diagram

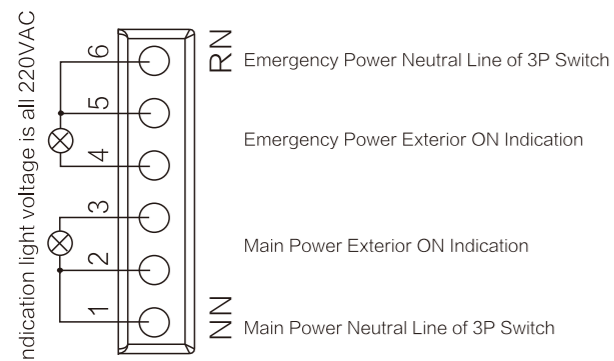

### Technical parameter

Pole	3P 4P
Rated voltage Ue(V)AC	400V
Rated current In(A)AC	6,10,16,20,25,32,40,50,63
Frequency (Hz)	50/60
Control voltage (V)	220V
Transfer time (S)	1.5 ~ 3s
Mechanical life (times)	10000

### The feature and character of ATS1 series ATS

ATS1 series Automatic Transfer Switch, is composite by 2pcs 3P or 4P miniature circuit breakers, mechanical chain transmission mechanism, controller, etc, the feature will be as follows:

- Small in volume, simple in constitution; There is provide 3P, 4P. Easy to operate and long to use;
- The transfer switch is driven by a single motor, which runs smoothly, without noise and with little impact;
- With mechanical interlock and electrical interlock, change over credibility, could be supplied by manual or automatic operation;
- The rated current of main power and standby power circuit breaker can be different;
- Inside of the products have the wiring terminal for users wiring, it can reflect breaker (open or closed) state;
- Have the short circuit, overload, over voltage, under voltage protection function, loss phase function and also the intelligent alarm function;
- Automatic switching parameters can be set freely outside;
- With computer network interface for remote control, remote adjustment and remote communication, remote sensing and other four control function and so on.

## ATS2 Series Automatic Transfer Switch

### Model Description

ATS	2	-	225	/	3P	63A
Product category	Design code	Current rank	Pole	Rated current		
CB Class Automatic Transfer Switch	2	63,100,225,400, 630,800	3P,4P	63A-800A		

### Outline and installation dimension

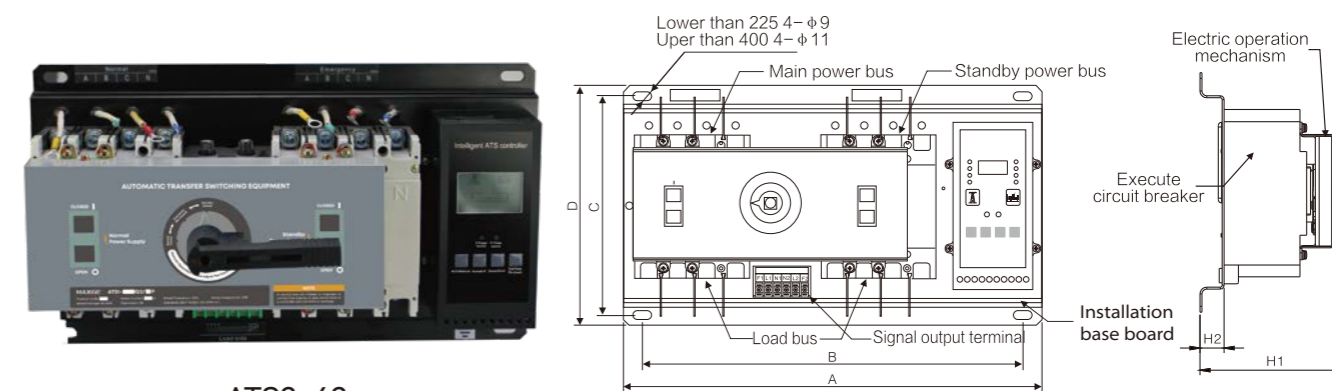

ATS2-63

Dimensions / Specification	A		D	B		C	H1	H2
	3P	4P		3P	4P			
ATS2-63	380	405	250	340	365	230	< 160	25
ATS2-100	405	435	250	365	395	230	< 170	25
ATS2-225	450	480	250	410	440	230	< 190	25
ATS2-400	570	620	330	510	560	300	< 200	25
ATS2-630	680	740	330	620	680	300	< 250	25
ATS2-800	750	820	330	690	760	300	< 250	25

## ATS2 Series Automatic Transfer Switch

### Technical parameter

Model	ATS2-100/225	ATS2-400	ATS2-630/800
Mechanical life	5000	3000	2500
Electric life	1000	1000	500
Rated working system	Uninterrupted working system		
Over voltage transfer adjustable value	270VAC		
Set the adjustable range of under voltage	(70%~85%)Ue Adjustable continuously		
Transfer time of contact	< 4s		
Open-transition delay time t1	0.5~30s Adjustable continuously		
Open-transition delay time t2	0.5~30s Adjustable continuously		

### The feature and character of ATS2 series ATS

ATS2 Series intelligent dual power automatic transfer switch is made up of 2pcs 3 poles and 4 poles of MCCB and auxiliary contact,alarm contact,the mechanical interlocking transmission,intelligent controller and other components.It has the integral style and split type with two kinds of mechanism. Integral controller is equipped with a base and executing agencies; Split type is intelligent controller installed in the panel. User takes the base by implementing agencies to install into the cabinet controller with an about 2m cables.

- Reliable mechanical interlock between the two circuit breakers and electrical interlock device. Eliminate the two devices closing completely at the same time.
- SCM intelligent controller used to control the core hardware is simple and powerful, expansion of convenience,high reliability.
- It has the short circuit, over load protection functions, over voltage,under voltage, loss phase automatic transfer function and intelligent alarm function.
- Automatic switching external parameters can be set free.
- Operation of Intelligent motor protection.
- The control circuit devices with fire, fire control center to a control signal into inteligent controller. Two sets circuit breaker will enter a stating of breaking.
- There is a computer network interface for achieving remote control four remote telemetry functions.

## ATS3 Series Automatic Transfer Switch

### Model Description

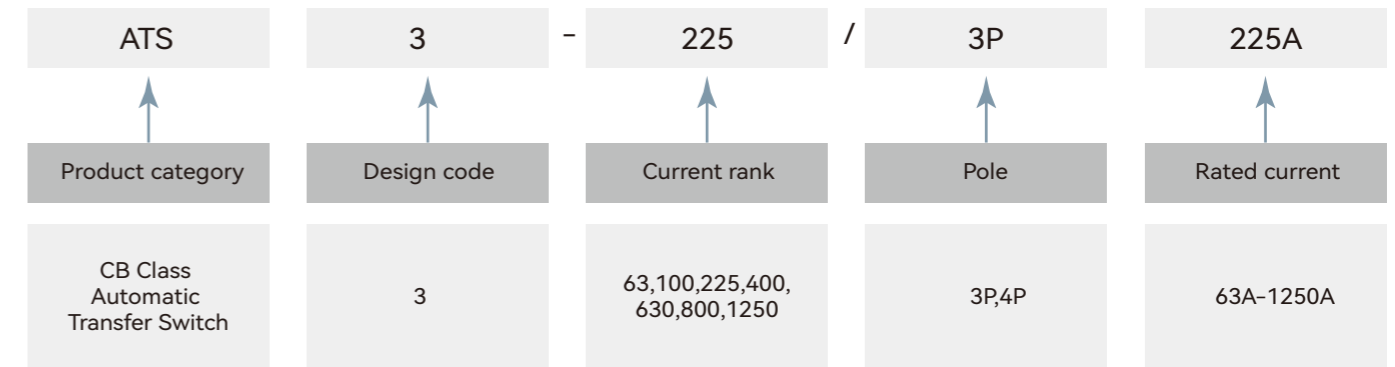

### Outline and installation dimension

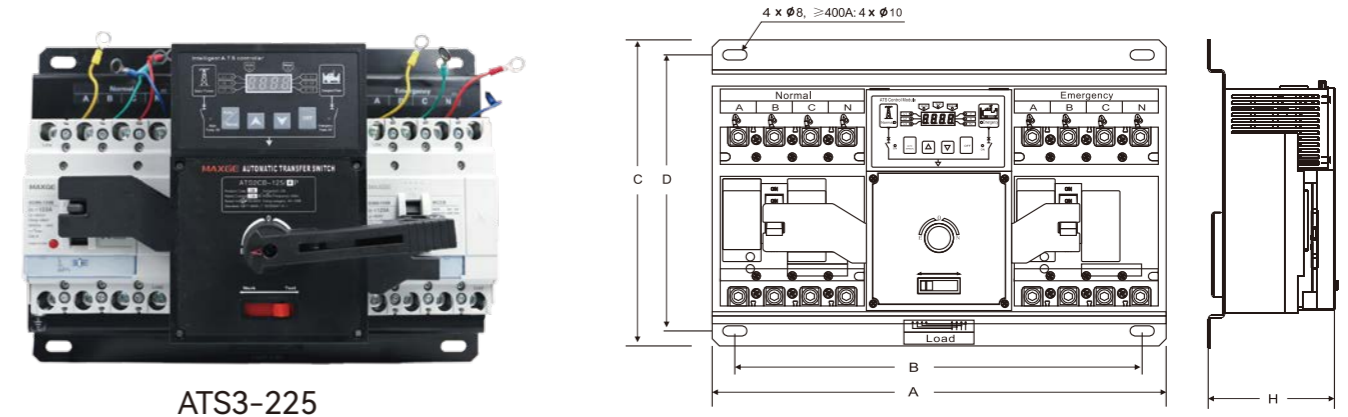

Specification	Dimensions A		Dimensions B		C	D	H
	3P	4P	3P	4P			
ATS3-63	285	320	245	280	255	230	141
ATS3-100	335	395	295	355	255	230	141
ATS3-225	365	435	325	395	255	230	155
ATS3-400	491	587	431	527	330	300	215
ATS3-630	524	640	464	580	330	300	215
ATS3-800	580	720	520	660	340	310	215
ATS3-1250	580	720	520	660	415	385	290

## ATS3 Series Automatic Transfer Switch

### ■ Technical parameter

Model	Rated current	Pole	Position	Drive	Controller
ATS3-63	16A,32A,63A	3P&4P	3 Positions	Motor type	Integral type controller
ATS3-100	80A,100A				
ATS3-225	125A,160A,200A,225A				
ATS3-400	315A,400A				
ATS3-630	500A,630A				
ATS3-800	800A				
ATS3-1250	1000A,1250A				

### ■ The feature and character of ATS3 series ATS

ATS3 Series intelligent dual power automatic transfer switch is made up of 2pcs 3 poles and 4 poles of MCCB and (auxiliary contact, alarm contact), the mechanical interlocking transmission, intelligent controller and other components. It has the integral style and split type with two kinds of mechanism. Integral controller is equipped with a base and executing agencies; Split type is intelligent controller installed in the panel. User takes the base by implementing agencies to install into the cabinet controller with an about 2m cables.

- Reliable mechanical interlock between the two circuit breakers and electrical interlock device. Eliminate the two devices closing completely at the same time.
- SCM intelligent controller used to control the core hardware is simple and powerful, expansion of convenience, high reliability.
- It has the short circuit, over load protection functions, over voltage, under voltage, loss phase automatic transfer function and intelligent alarm function.
- Automatic switching external parameters can be set free.
- Operation of Intelligent motor protection.
- The control circuit devices with fire, fire control center to a control signal into intelligent controller. Two sets circuit breakers will enter a stating of breaking.
- There is a computer network interface for achieving remote control four remote telemetry functions.

## ATS4-GA Series Automatic Transfer Switch

### ■ Model Description

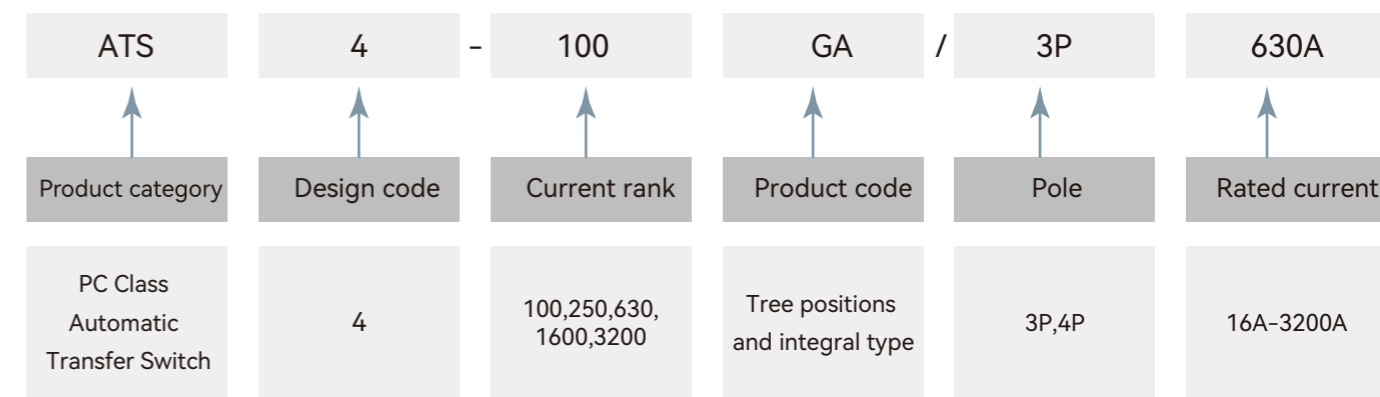

### ■ Outline and installation dimension



ATS4-100GA



ATS4-1600GA

ATS4-100GA

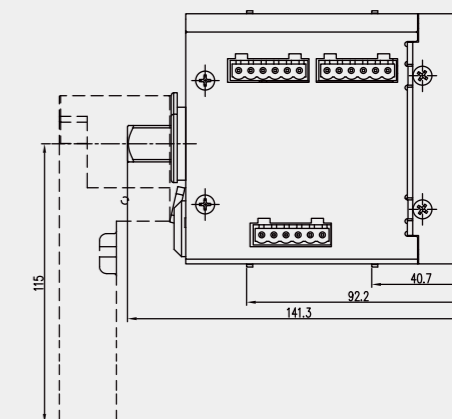
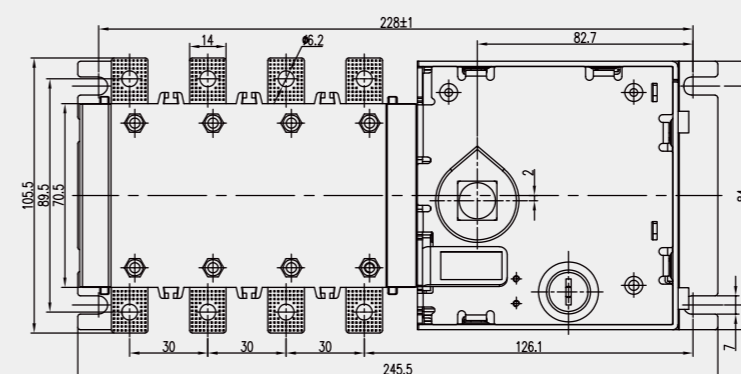

ATS4-GA Series Product Dimension Drawing

ATS4-160GA

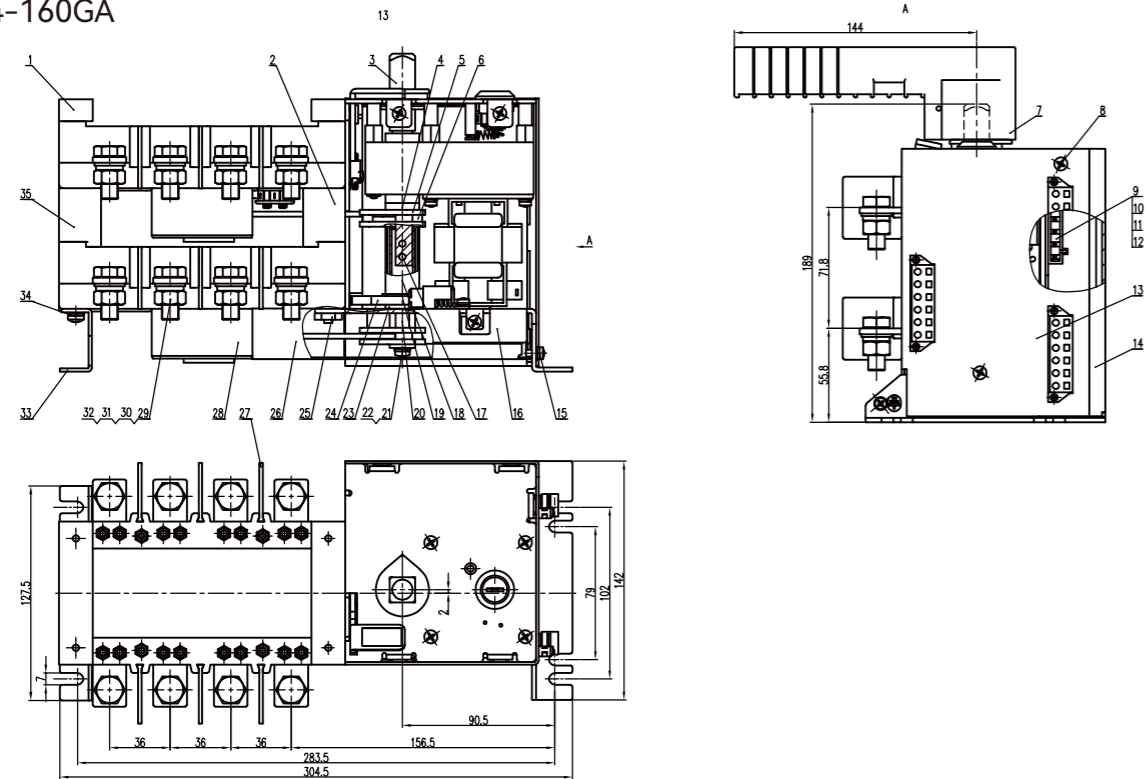

ATS4-250GA

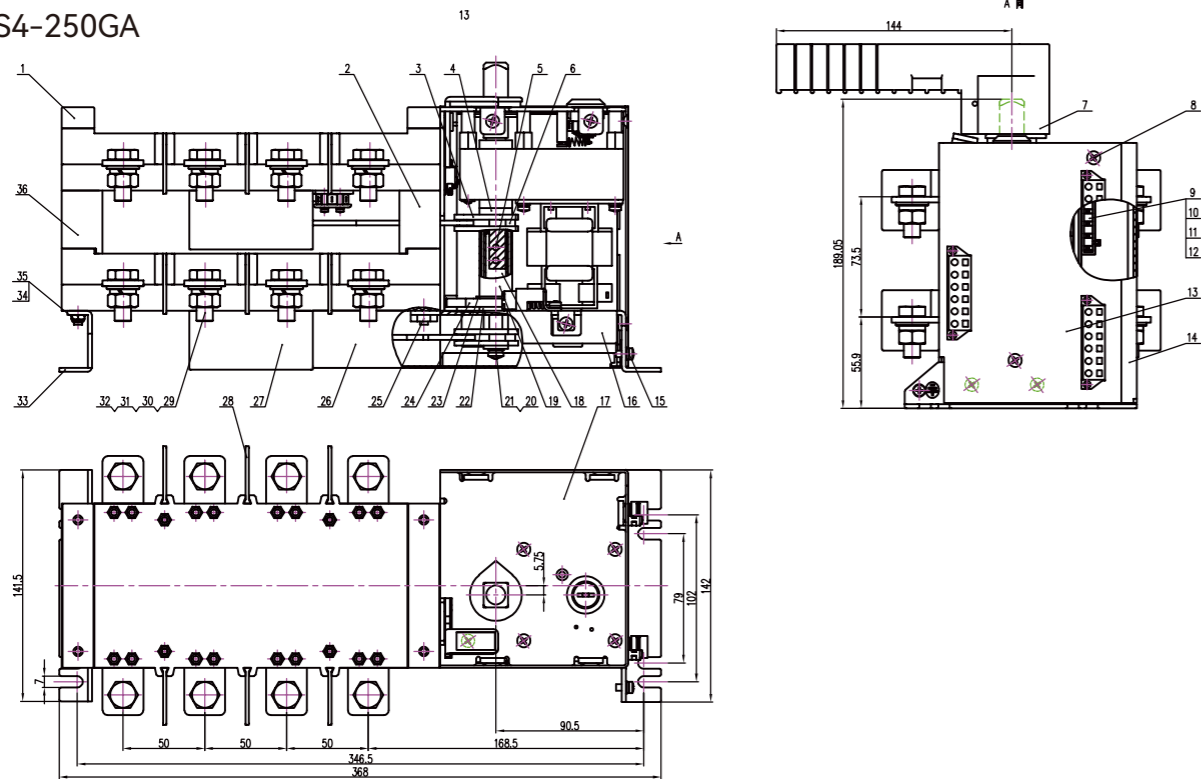

ATS4-GA Series Product Dimension Drawing

ATS4-630GA

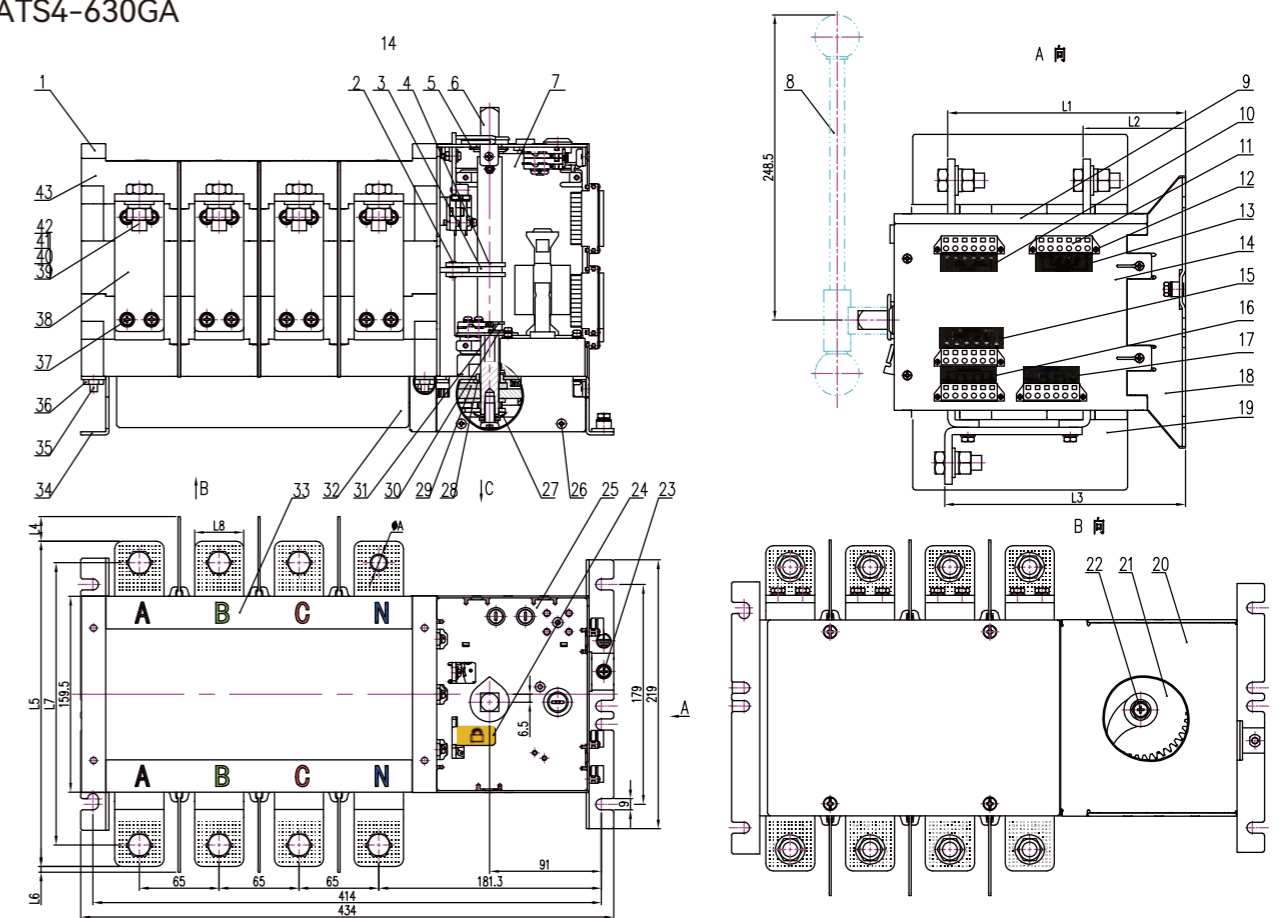

ATS4-1000-1600GA

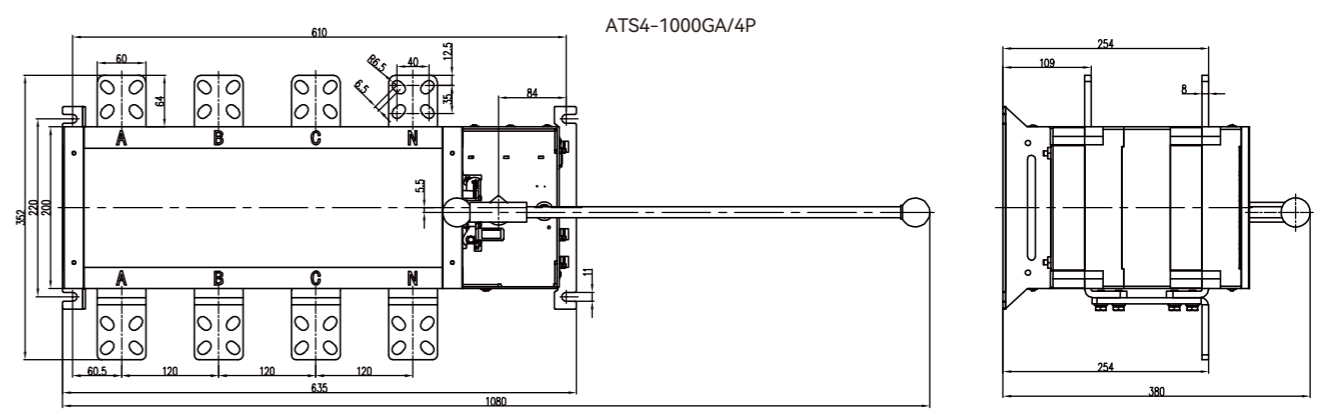

## ATS4-GA Series Product Dimension Drawing

ATS4-1000-1600GA

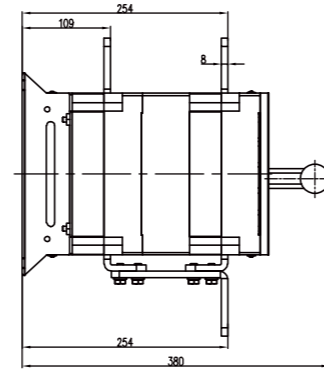
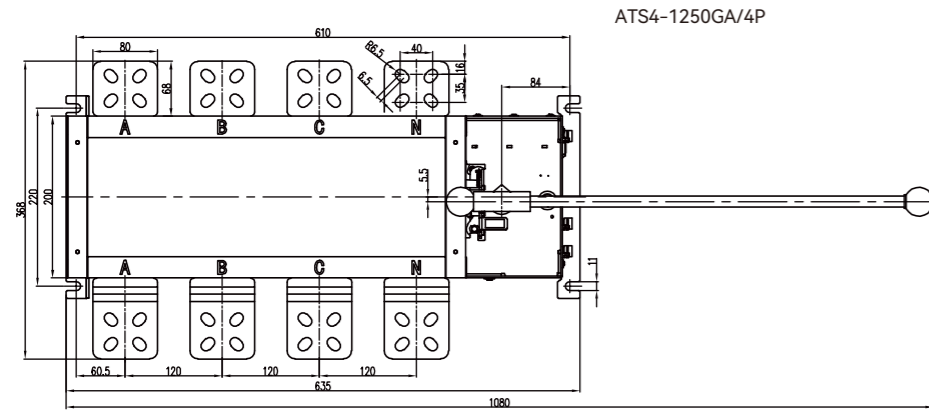

ATS4-1600GA/4P

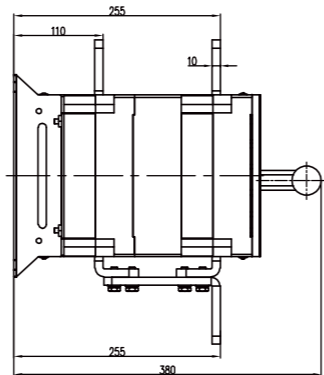
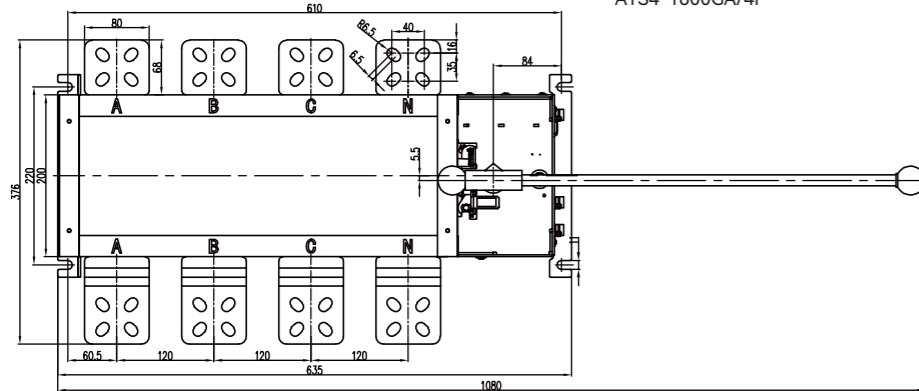

## ATS4-GA Series Product Dimension Drawing

ATS4-1000GA/3P

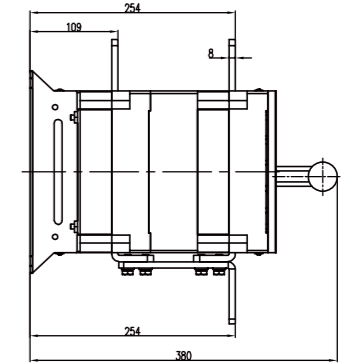
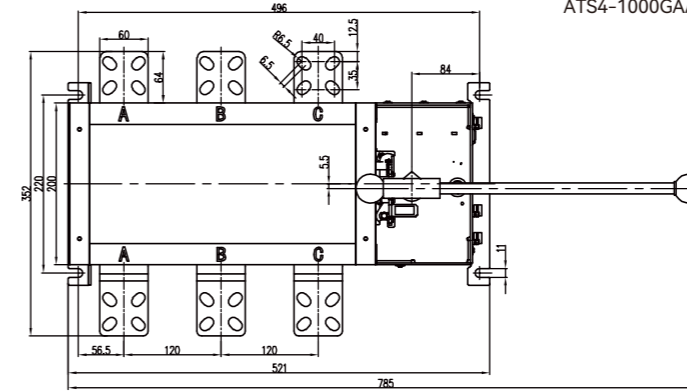

ATS4-1250GA/3P

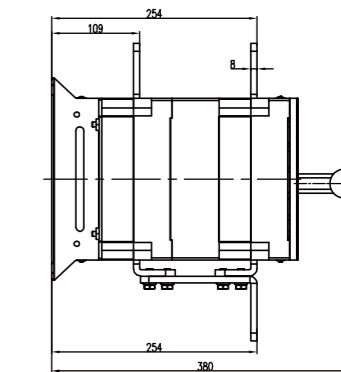
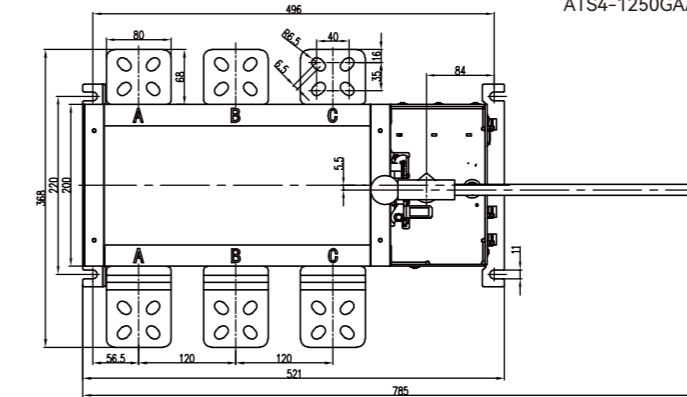

ATS4-1600GA/3P

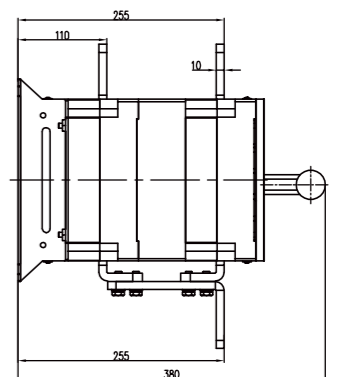
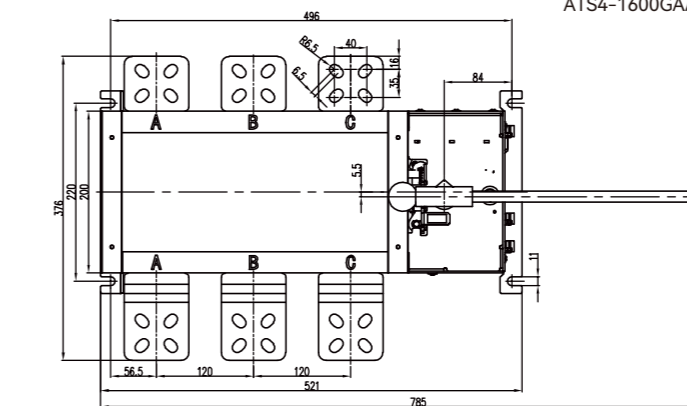

# ATS4-GA Series Automatic Transfer Switch

## Technical parameter

Model	ATS4-GA																																			
Rated current (Ith)	100			250			630			1600			3200																							
Rated working current(Ie)	16	20	25	32	40	50	63	80	100	125	160	225	250	400	630	800	1000	1250	1600	2000	2500	3200														
Rated insulation voltage(Ui)	500V																																			
Rated concussion withstand voltage(Uimp)	8kV																																			
Rated working voltage(Ue)	AC400V																																			
Using classes	AC-33B																																			
Rated limited shortcircuit current(Is)	8kA			26kA			67kA																													
Rated short-time withstand current(Is)	5kA			12.6kA			32kA																													
Transfer I-II or II-I	2.5s			0.6s			1.2s			1.8s			2.4s																							
Control power voltage	DC24V, 48V, 110V, AC220V																																			
Rated frequency	Start	325W			355W			400W			440W			600W																						
	Normal	62W			74W			90W			98W			120W																						
Weight(kg) 4 pole	3.4			6.0			7.6			15.8			16.8			36			36			37			38.6			55			61			67		

## The feature and character of ATS4 series ATS

ATS4 series ATSE is made up of switch body and transfer controller. The switch is driven by electromagnetic coil, so the transfer speed is very fast. The power source of controller takes main power or emergency power AC220V as working voltage.

- GA type is integral type, 3 positions.
- Split type products can be used together with Y-70 series intelligent dual power controllers.
- Integral and split type ATSE both with over voltage, under voltage, default phase, etc. Fault detection function and also with generator star and stop signal output function (When main power fault, the signal will be sent out after 3s time delay. When main power recover, the signal will be stopped after 3s time delay).

